

Preface

Preface

Dear customers...

...since ancient times, mankind has been thinking of effective ways of transporting and using "aqua" (lat. for water) and "therm" (lat. for warmth).

Applied technologies have been developed and changed considerably over the ages, but the motivation has remained the same: Hygiene, health and well-being.

aquatherm has participated in this development over the past 34 years and in some areas has been able to make decisive contributions. An example is the fusiotherm®-system produced by aquatherm.

And the material fusiolen® PP-R made by aquatherm is the first pipe material which is approved by the worldwide known environmental organization Greenpeace to mark with the logo "Product approved by Greenpeace".

By constantly adapting its products to the needs of the market and developing the relevant know-how, aquatherm has achieved worldwide success and prestige within the last 34 years: a fact which we are proud of, but at the same time giving us the motivation to continue making constant improvements.

This documentation is to give you a first idea of our products and services - and to make you curious to gain more information.

In case of further questions and of course also suggestions, we and our team will be pleased to be at your disposal!

Gerhard Rosenberg

Founder and Manager of aquatherm GmbH



1973

Founding of aquatherm by Gerhard Rosenberg

1978

Transfer to the first factory in Biggen / D-Attendorn

1985

Completion of factory 1 in Biggen / D-Attendorn

1992

Founding of the branch in Radeberg near D-Dresden

1996

Founding of the metal processing company aquatherm metal, D-Attendorn

1998

Founding of a subsidiary in Carrara / Italy

1999

Completion of the main site in D-Attendorn as one complex (Factories 1+2, Production and Store, Laboratory and Training Centre)

2001

Completion of the extension Factory 2 in D-Attendorn

2001

Opening of the new training centre in D-Radeberg

2002

Completion of the logistics centre in D-Attendorn

2003

Completion of rebuilding and finishing of the training centre in D-Attendorn

2003

30 year celebration of the company aquatherm

2005

Adding of 2 storeys on the administration building

2005/06

Completion of the 4-storey hall on the premises in Attendorn

Basement: Store

Ground floor: Assembly / Packing

1st Floor: Laboratory and Technical department

2nd Floor: Special manifold construction

2008

Aquisition of the former storehouse of the forwarding agent Kost, which also accomodates the room of the plant maintenace.

2008

Opening of the new expertise centre for technical application.

Service



Field staff / Infomobil

In addition to the regular training service at Attendorn and Radeberg aquatherm field staff are available to assist customers, on site, throughout Germany.



Laboratory

The aquatherm laboratory: from the testing of granulate through to the finished product the customer can be assured of only the highest quality products.



Training service

In addition to training service through the merchant network aquatherm offers its customers training, free of charge, at its training centres at Attendorn and Radeberg.



Software-Service

The aquatherm-software service provides Datanorm-files, an independent graphical program (liNear), and the appropriate training.



Fair

aquatherm is represented on all important fairs relevant for the sanitary and heating sector in Germany or abroad with its own exhibition booth. For more information regarding fairs near to you, please call +49 (0) 2722 950-425 or visit internet page: www.aquatherm.de.



Miscellaneous

Different aquatherm-CD's, prospects, catalogues, poster, leaflets, mailings, calendars, a.s.m. are investigated and produced from the internal advertising department. All information regarding the company, the technology, the products, the various trainings and fairs as well as all catalogues in pdf-form can be called and downloaded from the aquatherm-website: www.aquatherm.de.

Contents

- Company profile	4
- Service	5
- Contents	6-7

Chapter 1:

Features 8

- Fields of application	9
- Potable water installations / Heating and cooling installations	10
- fusiotherm® PP-R	11
- Material properties	12
- Ecology	13
- Permissible working pressures for potable water installations	14
- Permissible working pressures for heating systems or closed systems	15
- Permissible working pressure for general pressure pipe applications out of the charted ranges application ranges on page 14 and 15	16
- Hygienic suitability / UV-resistance / Sound insulation / Fire protection	17
- Fire load / Fire protection / Combustion values V [kWh/m] for fusiotherm®- and climatherm-pipes	18
- Advantages	19
- Types of installation	20
- Installation principles	21
- System components / Chemical resistance	22
- climatherm - advantages and fields of application / System components	23
- Fields of application of the fusiotherm®- and climatherm-pipe systems / Water content per meter by comparison	24

Chapter 2:

Quality assurance 26

- Laws / regulations / decrees / System standards	27
- Compliance with the system standard / Quality management system	28
- System control / Internal control	29
- Test and acceptance of incoming goods / In-process inspection and test / Process control / Final inspection and test	30
- External control / Storage / packing / dispatch	31
- Test certificates	32

Chapter 3:

Fusion for fusiotherm® and climatherm 34

- Part A: Mounting of the tools	35-37
Part A: Heating up phase / Handling	
Part A: Guidelines / Part B: Checking of devices and tools	
- Part B: Preparation for the fusion	38-40
Part B: Heating of pipe and fitting	
Part B: Setting and alignment	
Part C: Weld-in saddles	

- Part C: Weld-in saddles	41-43
- Part D: fusiotherm®-Electrical welding jig	44-45
Preparation for the fusion / Fusion	
- Part E: fusiotherm®-welding machine	46
- Part F: fusiotherm®-electrofusion device / Technical Information / General and inspection / Preparation / Fusion / Assembling the fusiotherm®-electrofusion sockets / Fusion process / Cooling time and pressure test / Working pressure / Pipe repairs with the fusiotherm®-electrofusion socket	47-50
Part G: Additional possibilities of repair	
- Teil H: Butt-welding of pipe dimension 160, 200 and 250 mm	51-52

Chapter 4:

Installation principles 54

- Fastening technique / Fixed points / Sliding points	55
- Installation advice / Linear expansion / Concealed installation	56
- Installation in ducts / fusiotherm®-pipe	57
- Open installation / Calculation of the linear expansion / Linear expansion comparison: faser composite to standard PP-pipe	58
- Linear expansion of fusiotherm®- and climatherm-pipes	59
- Linear expansion of fusiotherm®- and climatherm-faser composite pipes	60
- Linear expansion of fusiotherm®-stabi composite pipes	61
- Bending side / Expansion loop	62
- Pre-stress / Bellow expansion joint	63
- Length of bending side	64
- Length of bending side with pre-stress	65
- Support intervals	66-67
- Thermal insulation of hot water pipes	68
- Insulation thickness of fusiotherm®-pipe SDR 6 and fusiotherm®-stabi- / faser-composite pipes SDR 7.4 / Insulation thickness of climatherm-faser-composite pipe SDR 11 / Thermal insulation of cold water pipes	69-70
- Pressure test / Test control / Measuring of the test pressures / Test record	71
- Pressure test / Test control	72
- Test record - fusiotherm®-pipe installation	73
- Flushing of pipes / Earth wire / Transport and storage	74
- Water point connections	75
- Distribution block: example of applications	76
- fusiotherm®-distribution block: example of applications - potable water	77
- Insulation for distribution block / aquatherm®-distribution block	78
- aquatherm®-distribution block: example of applications - heating	79

Contents

Chapter 5:

Planning 80

- DIN 1988 T 3 / Maximum flow rate / Principles of calculation / Calculation guide / Software 81
- Minimum flow pressure / Calculated flows of common water points 82
- Minimum flow pressure 83-84
- fusiotherm®- and climatherm-pipe systems: Pipe friction factor R and calculated flow rate v in dependence on the volumetric current \dot{V} 85-119
- Coefficient of loss ζ fusiotherm®-fittings 120-122
- Coefficient of loss ζ fusiotherm®-distribution block 123

Chapter 6:

Product range 124

- fusiotherm®-pipe SDR 6 125
- fusiotherm®-pipe SDR 7.4 126
- fusiotherm®-pipe SDR 11 127
- fusiotherm®-faser composite pipe technology 128
- fusiotherm®-faser composite pipe SDR 7.4 129
- fusiotherm®-faser composite pipe SDR 7.4 UV 130
- fusiotherm®-stabi composite pipe SDR 7.4 131
- climatherm-pipe SDR 11 132
- climatherm-faser composite pipe SDR 7.4 / SDR 11 133
- climatherm-faser composite pipe SDR 7.4 / SDR 11 UV 134
- aquatherm® lilac-pipe SDR 7.4 / SDR 11 135
- Accessories 136
- Accessories and fittings 137
- Fittings 138-146
- Fittings, armature connections and accessories 147
- Armature connections and accessories 148
- Accessories and transition pieces 149-150
- Transition pieces 151-153
- Transition pieces and threaded adapter 154
- Threaded adapter and counter parts 155-156
- Weld-in saddle 157
- Distributors and accessories 158
- Valves and accessories 159-162
- Radiator connections 163-164
- Radiator connections / Cutting Tools 165
- Welding devices 166-167
- Welding devices and accessories 168
- Welding tools and peeling tools 169
- Peeling tools 170
- Welding tools and accessories 171
- Accessories 172
- Legend 173

Chapter 1

Features

Fields of application

fusiotherm® - a pipe system with many applications due to its special characteristics and versatility.

- **Potable water pipe networks**
for cold and hot water installations e.g. in residential buildings, hospitals, hotels, office and school buildings, shipbuilding, sports facilities etc.
house connection
boiler connection
water distribution
riser
high rise
(conventional or specially connected)
water point connection
- **Heating pipes for residential houses**
heat generator connections
heating manifolds
risers
high rise
manifold connections
radiator connections
- **Pipe networks for rainwater application systems**
- **Pipe networks for compressed-air plants**
- **Pipe networks for swimming pool technology**
- **Pipe networks for the connection of heat pumps**
- **Pipe networks in agriculture and horticulture**
- **Pipe networks for geothermal recovery**
- **Pipe networks for industry,**
e.g. for the transport of aggressive fluids
(acids, leys, etc.) considering the chemical resistance

The fusiotherm®-pipe system is applied in all fields of

- NEW INSTALLATION
- REPAIR AND
- RENOVATION.



Manifold construction with fusiotherm®- and climatherm-faser composite pipe and big ball valve



Potable water installations / Heating and cooling installations



From the house connection station, cold water distribution, boiler connection and hot water distributor...



Flange connections and transition joints enable the connection of all components to the central heating system and on the floor.



...to risers, installed with fusiotherm®-composite pipe, with conventional high rise or high rise carried out with the fusiotherm®-manifold system...

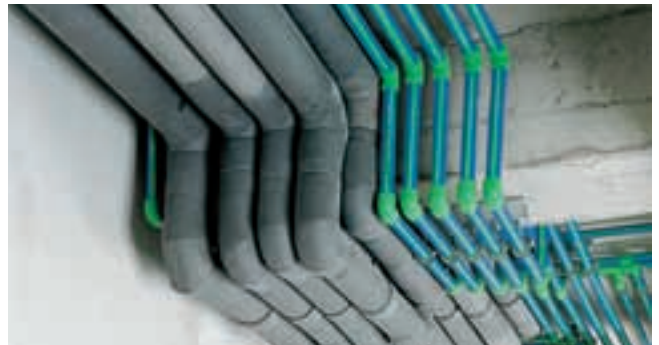

Risers and distribution piping for heating supply should be planned and installed with climatherm-faser composite pipes.



...up to the last tap, installed conventionally or with the manifold, concealed or surface installation - the fusiotherm®-pipe system offers all possibilities of a complete installation with only one non-polluting material.



The connection of floor heating systems or the installation of radiator pipes up to the manifold can also be carried out with climatherm.

IMPORTANT:

The aquatherm® SHT domestic water and radiator connection system is compatible with the fusiotherm® pipe system.



fusiolen® PP-R

All fusiotherm®-pipes and fittings are made of fusiolen® PP-R.

Special heat and extraction stability are only two of the features of this material. Its physical and chemical properties are well-suited to the transfer of potable water and to the heating field. Above all, the good welding properties and fusion, resulting in a permanent connection, have made the fusiotherm®-system and the raw material fusiolen® PP-R well known worldwide.

Environment

The environmentally friendly material polypropylen fusiolen® PP-R is recyclable and can be ground, melted and reutilised for various applications e.g. motor-protections, wheel linings, laundry baskets and other kinds of transport boxes. There are no polluting substances with PP-R either in its processing or in its disposal.

fusiolen® PP-R – for the benefit of our environment!

Use of metal deactivators

By adding suitable food-approved additives the risk of a material damage caused by metal under extreme conditions of application is substantially reduced.

Higher long-term heat stabilization

The long-term heat stabilization has been increased to resist to the potential effects of peak temperatures within higher safety parameters.

THE ADVANTAGES AT ONE SIGHT:

RESISTANT AGAINST CHEMICALS

SMELL- AND TASTE NEUTRALITY

PHYSIOLOGICAL SUITABILITY

HIGH ENVIRONMENTAL COMPATIBILITY

HIGH IMPACT RATE

LESS PIPE FRICTION

HEAT- AND SOUND INSULATING CHARACTERISTICS

VERY GOOD WELDING PROPERTIES

HIGH HEAT -STABILITY

EQUIPPED WITH METAL DEACTIVATION

Product approved by

GREENPEACE

Material properties

Material properties

Potable water is one of the most controlled commodity goods.

The domestic supply system should influence the water on its way up to the taps as less as possible. The choice of the right potable water pipe system and its material is of decisive importance.

fusiotherm®-pipe systems are suitable for all different qualities of potable water.

The environmentally friendly and hygienically enhanced potable water pipe system made from fusiotherm® is physiologically and microbio-logically harmless. The technical suitability of the fusiotherm®-pipe system has been evident worldwide for more than 20 years.

Numerous international certificates like

- ➔ DVGW, SKZ (Germany)
 - ➔ AENOR (Spain)
 - ➔ ÖVGW (Austria)
 - ➔ WRAS (UK)
 - ➔ SVGW (Switzerland)
 - ➔ KIWA (Netherlands)
 - ➔ SAI-Global (Australia)
 - ➔ CRECEP (France)
 - ➔ SII (Israel)
 - ➔ SIRIM (Malaysia)
 - ➔ TIN (Poland)
 - ➔ LNEC (Portugal)
 - ➔ SITAC (Sweden)
 - ➔ NSF, ICC (USA)
- a.m.m.

testify to the high quality standard of the green pipes.

The extrapolated service life of fusiotherm®-pipes is more than 50 years. Peak temperatures of 100° C arising from short disruptions are unproblematic.

Permanent temperatures from 70°C up to 90° C reduce the service life of the pipe (see table "Permissible Working Pressure", page 14, 15 and 16)

Using fusiotherm® or climatherm pipes for heating or air conditioning applications the pressure- and temperature conditions according to table "Permissible Working Pressure" are valid.

The following table shows the operating conditions related to pressure and temperature as a basis for pipe and pipe connections.

These figures refer to potable water installations based on a theoretical service life of 50 years.

	Working pressure	Temperature	Annual working hours
	bar (psi)	°C (°F)	h/a
Cold water	0 upto 10 (145) transient	to 25 (77)*	8760
Hot water	0 upto 10 (145) transient	to 60 (140) to 85 (185)	8710 50

* Reference temperature for the creep rupture strength: 20°C (68°F)

Ecology

Ecology

Environmental protection is taken seriously by aquatherm!

Products such as the fusiotherm® pipe system feature not only a long service life, but also excellent environmental and social compatibility.

From the origin of the company aquatherm placed emphasis on the fact that its products and manufacturing processes should not pollute our sensitive ecosystems, and ensured development of fully recyclable materials which can thus be added, problem-free, to new production.

Long before environmental protection was recognised as a global issue the fusiotherm® pipe system fulfilled ecological standards which are demanded today.

For over 30 years aquatherm has underlined its philosophy that ecological and economic interests should not be contradictory, neither during production and sales, nor in the application of product.

The environmentally friendly raw material fusiolen® PP-R is used for the manufacture of the fusiotherm® pipe system. To ensure its environmental compatibility the basic material polypropylene, as well as all contained additives (colour pigments and stabilizers) were extensively tested, not only by aquatherm's own laboratory, but also by independent laboratories.

Their results show that the material fusiolen® PP-R and the fusiotherm® pipe system from which it is manufactured, comply with the highest ecological standards and are thus future-oriented.

Prime ecological advantages:

- **PVC free**
- **The additive share of the fusiolen® material is below 3%**
- **Free from heavy metals hazardous to health (e.g. Cu, Pb, N)**
- **Longevity**
- **Recyclable**



Permissible working pressure

for potable water installations

Fluid transported: water acc. to DIN 2000

Temperature	Service life	fuviotherm®- pipe SDR 11	fuviotherm®- pipe 6	fuviotherm®- faser composite pipe SDR 7.4
			fuviotherm®- stabi composite pipe	
Permissible working pressure in bar and (psi)				
20°C 68°F	1	15.0	30.0	28.6
	5	14.1	28.1	26.8
	10	13.7	27.3	26.1
	25	13.3	26.5	25.3
	50	12.9	25.7	24.5
30°C 86°F	1	12.8	25.5	24.3
	5	12.0	23.9	22.8
	10	11.6	23.1	22.0
	25	11.2	22.3	21.3
	50	10.9	21.8	20.7
40°C 104°F	1	10.8	21.5	20.5
	5	10.1	20.2	19.2
	10	9.8	19.6	18.7
	25	9.4	18.8	18.0
	50	9.2	18.3	17.5
50°C 122°F	1	9.2	18.3	17.5
	5	8.5	17.0	16.2
	10	8.2	16.5	15.7
	25	8.0	15.9	15.2
	50	7.7	15.4	14.7
60°C 140°F	1	7.7	15.4	14.7
	5	7.2	14.3	13.7
	10	6.9	13.8	13.2
	25	6.7	13.3	12.6
	50	6.4	12.7	12.1
Potable water (cold) Potable water (warm)	65°C 149°F	1	14.6	13.9
		5	13.6	12.9
		10	13.1	12.5
		25	12.6	12.0
		50	11.1	10.6
	70°C 158°F	1	13.0	12.4
		5	11.9	11.4
		10	11.7	11.1
		25	10.1	9.6
		30	8.8	9.3
	50	8.5	8.1	
	75°C 167°F	1	12.3	11.7
		5	11.4	10.8
		10	10.5	10.0
			25	8.4

Faser and Stabi composite pipe: high working stress at lower wall thickness and higher flow rate

* SDR = Standard Dimension Ratio
(diameter / wall thickness ratio)
SDR = 2 x S + 1 ≈ d/s
(S = Pipe series index from ISO 4065)

Permissible working pressure

heating systems or closed systems

Heating period	Temperature	Service life	climatherm- pipe SDR 11 / faser composite pipe SDR 11	fusiotherm®- faser composite pipe SDR 7.4	fusiotherm®- stabi composite pipe	fusiotherm®- pipe SDR 7.4
			Permissible working pressure in bar and (psi)			
constant operating temperature 70 °C / 158 °F incl. 30 days per year at	75 °C 167 °F	5	9.38		14.27	11.33
		10	9.08		13.79	10.95
		25	7.82		11.74	9.32
		45	6.77		10.18	8.08
	80 °C 176 °F	5	8.88		13.50	10.72
		10	8.46		12.80	10.16
		25	7.38		11.14	8.84
		42.5	6.49		9.79	7.77
	85 °C 185 °F	5	8.17		12.42	9.85
		10	7.82		11.87	9.42
		25	6.70		10.14	8.05
		37.5	6.07		9.18	7.29
	90 °C 194 °F	5	7.50		11.39	9.04
		10	7.19		10.94	8.69
		25	5.85		8.86	7.03
		35	5.39		8.16	6.48
constant operating temperature 70 °C / 158 °F incl. 60 days per year at	75 °C 167 °F	5	9.26		14.11	11.20
		10	8.90		13.57	10.77
		25	7.62		11.58	9.19
		45	6.60		10.05	7.97
	80 °C 176 °F	5	8.61		13.12	10.41
		10	8.24		12.54	9.96
		25	6.93		10.56	8.38
		40	6.18		9.41	7.47
	85 °C 185 °F	5	7.91		12.03	9.55
		10	7.56		11.52	9.14
		25	6.05		9.22	7.31
		35	5.57		8.48	6.73
	90 °C 194 °F	5	7.25		11.04	8.76
		10	6.40		9.76	7.75
		25	5.12		7.81	6.20
		30	4.90		7.46	5.92
constant operating temperature 70 °C / 158 °F incl. 90 days per year at	75 °C 167 °F	5	9.17		14.02	11.12
		10	8.79		13.38	10.62
		25	7.45		11.33	8.99
		45	6.45		9.82	7.80
	80 °C 176 °F	5	8.46		12.90	10.23
		10	8.11		12.35	9.80
		25	6.60		10.05	7.97
		37.5	5.98		9.09	7.21
	85 °C 185 °F	5	7.76		11.81	9.37
		10	7.03		10.72	8.51
		25	5.63		8.58	6.81
		32.5	5.28		8.03	6.37
	90 °C 194 °F	5	6.96		10.59	8.41
		10	5.88		8.96	7.11
		25	4.70		7.17	5.69

* SDR = Standard Dimension Ratio (diameter / wall thickness ratio)
SDR = 2 x S + 1 ≈ d / s
(S = Pipe series index from ISO 4065)

Permissible working pressure

for general pressure pipe applications out of the charted application ranges on page 14 and 15

Temperature	Service life	climatherm- faser-composite pipe SDR 11 / climatherm-pipe SDR 11	climatherm- faser-composite pipe SDR 7.4
		Permissible working pressure in bar and (psi)	
10°C	1	27.8	43.2
	5	26.2	40.7
	10	25.6	39.7
	25	24.7	38.3
	50	24.1	37.4
	100	23.5	36.4
15°C	1	25.7	39.9
	5	24.2	37.5
	10	23.6	36.6
	25	22.8	35.3
	50	22.2	34.4
	100	21.6	33.5
20°C	1	23.8	36.8
	5	22.3	34.6
	10	21.7	33.7
	25	21.0	32.5
	50	20.4	31.7
	100	19.9	30.9
30°C	1	20.2	31.3
	5	18.9	29.4
	10	18.4	28.6
	25	17.8	27.5
	50	17.3	26.8
	100	16.8	26.0
40°C	1	17.1	26.6
	5	16.0	24.9
	10	15.6	24.1
	25	15.0	23.2
	50	14.6	22.6
	100	14.1	21.9
50°C	1	14.5	22.5
	5	13.5	21.0
	10	13.1	20.4
	25	12.6	19.6
	50	12.2	19.0
	100	11.9	18.4
60°C	1	12.2	19.0
	5	11.4	17.7
	10	11.0	17.1
	25	10.6	16.4
	50	10.3	15.9
	100	10.3	16.0
70°C	1	10.3	16.0
	5	9.6	14.8
	10	9.2	14.3
	25	8.0	12.5
	50	6.8	10.5
	100	6.8	10.5
75°C	1	9.4	14.6
	5	8.7	13.5
	10	8.0	12.5
	25	6.4	10.0
	50	5.4	8.4
	100	5.4	8.4
80°C	1	8.6	13.4
	5	7.7	11.9
	10	6.5	10.0
	25	5.2	8.0
	50	4.3	6.6
	100	4.3	6.6
90°C	1	7.2	11.2
	5	5.1	7.8
	10	4.3	6.6
	25	3.5	5.4
	50	3.5	5.4
	100	3.5	5.4

* SDR= Standard Dimension Ratio
(diameter / wall thickness ratio)
 $SDR = 2 \times S + 1 \approx d/s$
(S= Pipe series index from ISO 4065)

Features

Hygienic suitability

According to DIN 1988 T2 all installation parts coming directly in contact with potable water are commodity goods acc. to the Law for Food and Commodity Goods. Plastic pipes have to comply with the KTW-recommendations of the Federal Public Health Department.

Material:

The hygienic suitability of the material used for the fusiotherm®-pipe system is independently verified through test certificates from the Hygiene Institute Gelsenkirchen. The suitability for potable water pipes in the field of cold and hot water is confirmed by current tests (see chapter 1+2).

Processing:

The joining method requires no additives such as fluxes or solder. The connection is made by socket fusion.

Potable water - our most precious commodity good:

The increasing use of PP in the field of foodpacking confirms the hygienic qualities of the material. This makes fusiotherm® **the optimal packing for our most precious commodity goods - potable water.**

UV-resistance

Pipes made from fusiolen® PP-R and fusiolen® PP-R C are normally not installed where subject to UV-radiation.

All fusiotherm®- and climatherm-pipes and -fittings have UV-stabilizer to bridge transport and installation times. Maximum storage time in the open air is 6 months.

For the application in open air aquatherm offers composite pipes with UV-protective layer made from polyethylene, which excludes damages caused by sunlight.

fusiotherm® and climatherm faser composite pipes with UV-protection are always available in stock.

Sound insulation

The sound insulation qualities of the PP-R pipe system, related to water flow and hydraulic shock within a building, provide a sound proofing effect on noise transmission.

Therefore the sound transmission is much lower compared to metallic pipes.

Fire protection

The fusiotherm®-pipe system and the climatherm pipes comply with the requirements of the fire classification B2 DIN 4102 (normal inflammable). Compared to natural products like wood, cork or wool, fusiotherm®- and climatherm-pipes do not produce any gas toxicity. In case of fire, there is no risk of dioxin emissions. To avoid fire and smoke transmission aquatherm advises the use of fire retardant seals. The fire resistance period is the minimum period in minutes.

The extent of the preventive measures depends on the type of installation. The determining of fire areas and fire classification has to be made in acc. with the law of the country. Information is given by the Planning Department and Building Control Office or the Fire Protection Representative.

Basically fire walls and ceilings with pipe passages have to be installed to the same fire resistance classification. All fire protection systems with a corresponding classification are suitable for fusiotherm®- and climatherm-pipes.

aquatherm recommends the Rockwool®-Conlit fire retardant seals as ideal solution for both systems. Detailed information about the draft-guidelines 2000 will be given by our technical hotline **+49 (0) 2722 950-111/116** or directly by Rockwool GmbH.

Features

Fire load

The values required for determining the fire load within a fire section are calculated from the total of all flammable materials located within this area.

The calculation for establishing the combustion heat V [kWh/m] for a fire section in the event of an outbreak is dependent on dimensions and materials.

The basis used for the calculation of fusiotherm®- and climatherm-pipes made of PP-R is the lower calorific value $H_U = 12.2$ kWh/kg (as per DIN V 18230 T1) in conjunction with the mass of material m_{pipe} [kg/m].

The integrated layers of aluminium or faser in fusiotherm®-/climatherm-stabi-composite or faser-composite pipes also are considered.

Depending on the calculation procedure, the fire load is worked out with reference to the burn-up factor. This value is designated as m_{factor} and is taken as 0.8 for polypropylene.

Fire protection

Fire protection for fusiotherm®- and climatherm-pipes

The latest pipe supply regulation draft determines the professional wall and ceiling duct and also the pipe insulation of escape and rescue routes.

The required pipe-insulation stipulated in this draft can be easily achieved by the fusiotherm®-pipe system and climatherm-pipes.

Combustion values V [kWh/m] for fusiotherm®- and climatherm-pipes

Dimension mm	SDR 11	SDR 7.4	SDR 6	fusiotherm®- stabi composite pipe	fusiotherm®-faser composite pipe SDR 7.4	climatherm-faser composite pipe SDR 11
16	-	1.17	1.5	1.62	-	-
20	1.32	1.82	2.12	2.04	1.76	-
25	2.01	2.83	3.27	3.18	2.74	-
32	3.18	4.54	5.33	5.04	4.39	3.14
40	5.05	7.05	8.24	7.57	6.83	4.83
50	7.82	10.99	12.77	11.06	10.64	7.48
63	12.35	17.28	20.26	17.27	16.72	11.82
75	17.21	24.58	28.68	24.80	23.79	16.48
90	24.92	35.21	41.22	36.84	34.08	23.86
110	36.89	52.68	61.45	58.75	50.98	35.33
125	47.87	-	-	-	65.65	45.85
160	78.32	-	-	-	107.28	74.94
200	121.39	-	-	-	167.72	116.73
250	189.10	-	-	-	261.64	181.64

1 kWh/m = 1040 btu/ft

Advantages

The following advantages are for both the fusiotherm® and climatherm pipe system.

The system includes all necessary components for a complete installation starting from watermeter up to the last tap. Mixed installations are things of the past.

Assembly

fusiotherm® stops corrosion damages. All materials are corrosion resistant and - compared to metallic pipes - have less noise flow rate. fusiotherm®-pipes are opaque - no danger of algae development.

Installation

fusiotherm® offers an unique and unrivalled connection process: material union by fusion. Shortest connection times are convincing:

e.g. outside diameter 20 mm = 8 sec.

fusiotherm®-connections can be hydraulic pressure tested or put into operation directly after their fusion. There are no extended waiting times.

Composite-technology

aquatherm developed a manufacturing method, realizing the integration of aluminium resp. a special faser mixture within the material polypropylene.

The result of this innovative technology is the singular compound of the different materials.

Price

fusiotherm® is a perfected pipe system of high quality material with an optimum cost-performance ratio.

fusiotherm®-stabi composite resp. faser composite pipes - more advantages:

- The linear expansion is reduced by at least 75 % compared with standard PP-pipes
- The flow rate is increased by 20 % due to smaller wall thickness.
- High stability
- The coefficient of linear expansion is nearly identical to that of metal pipes, so that compared with usual plastic pipes the support intervals can be enlarged and the number of clamps can be reduced.
- Optimum cost-performance ratio

- Lower weight
- High impact rate
- Simply cut and weld

Important:

No peeling on using faser composite pipe.

Quality

This is reflected in national and international certificates, but above all in the satisfaction of fusiotherm®-clients, installers and planners.

For more details regarding quality and certificates see chapter 2.

Guarantee

As a statement to aquatherm quality standards the fusiotherm®-pipe system carries a 10 year guarantee for pipe and fittings with a product liability of 4.5 Mio. EUR per damage event.

Planning and software

A great number of planning documents and submission sheets facilitate the planning of the fusiotherm®-system. These documents give planner and installer a complete survey about the features of fusiotherm® and make their work easier.

They can plan graphically e.g. fusiotherm® with the **liNear SHK trade 5.0 CAD software package for domestic technology:**

- U-value calculation incl. material list
- EnEV 2002
- Heat requirement acc. to DIN EN 12831 up to 60 rooms
- Radiator calculation for 5 products up to 60 radiators
- Under-floor heating calculation acc. to EN 1264
- Graphical supply network calculation for heating (maximum 60 radiators) and for potable water acc. to DIN 1988 (maximum 60 water points).
- Program for offer (3 titles with 50 positions) incl. UGS- and ASD-cut
- AutoCAD OEM with drawing assistant for easy construction of supply networks
- Detailed manual and program protection adapter

For further information please call :

+49 (0) 2722 950-0

Types of installation

The **fusiotherm**[®]-pipe system is applicable for all common types of installation:



Distribution network for domestic water and heating in residential buildings



Manifold heating technique



Concealed installation



Surface installation

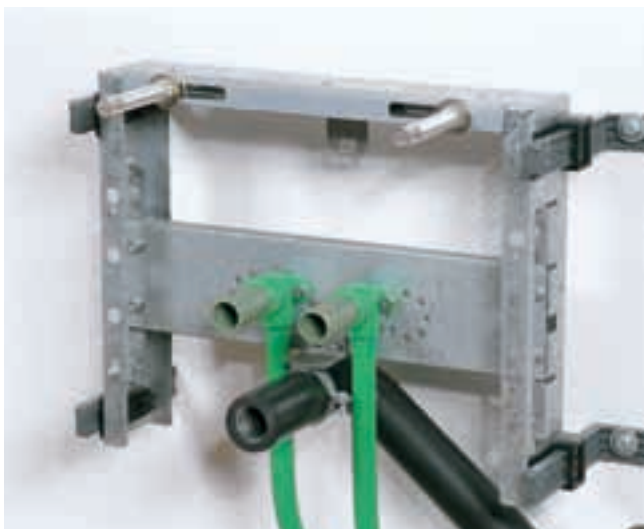

Front wall installation

It is also possible to prefabricate pipe and fittings for risers and high rise.

fusiotherm[®] offers the perfect program for all types of installations.

With an extensive product range of pipe and fittings from Ø 16 -160, 200 and 250 mm external diameter and more than 450 fittings including fittings with brass threaded metal inserts, fusiotherm[®] offers ideal solutions for all fields of application.

Installation principles

All risers and distribution pipes are planned and assigned as usual.

1. Distribution piping with composite pipes

More dimensionally stable pipes are recommended for conventionally installed basement pipes, risers and multi story pipe-systems.

Multi-storey installation can be done with the distribution blocks for plumbing and heating: quick processing is guaranteed.

Due to the low demand in fittings, the number of connections is reduced and thus time for installation.

High degree of pre-fabrication:

the special construction allows floor or wall installation (e. g. behind skirting boards) as one compact fitting with all branches provided.



2. Floor distribution with distribution blocks

The distribution blocks also offer further installation options: A simple opening of a side branch by drilling (18 mm borer) enables the connection of an additional pipe. e.g. the circulation pipe.

For further information concerning the distribution block plumbing and heating see chapter 4.



System components / Chemical resistance

System components

The fusiotherm®-pipe system consists of:

- pipes in straight lengths and/ or coils
- fittings
- flanged joints
- water point connections and accessories
- welding devices and machines
- weld-in saddles
- manifolds
- shut-off devices
- cutting and peeling tools
- installation guide and fastenings
- transition joints from **PP-R** to metal or from metal to **PP-R**

Chemical resistance

Due to their special material properties fusiotherm®- resp. climatherm-pipes and fittings are generally chemical resistant. However fusiotherm®-transition elements with brass inserts are not suitable for all media.

For industrial application of fusiotherm®-pipes it is advisable to use fusiotherm®-flanges and/ or coupling screws.

ADVICE:

If required you get threaded inserts even of stainless steel for fusiotherm®-transition pieces.

Prices on demand!

Enquiry for the chemical resistance of the fusiotherm®-/ climatherm-pipe system

aquatherm GmbH

Technical department

Biggen 5 · D-57439 Attendorn

Phone: +49 (0) 2722 950-0 · Fax: +49 (0) 2722 950-290

E-mail: info@aquatherm.de

Internet: www.aquatherm.de

Installer:

Company:

Contact _____

Street _____

PC/ City _____

Phone _____

Fax _____

E-mail _____

Building project:

Address:

Street _____

PC/ City _____

Place, Date/ Signature

Field of application:

Fluid transported

Operating temperature _____ °C/ °F

Working pressure _____ mbar/ psi

Service life _____ h/ d

Concentration _____ %

Ambient medium:

Ambient temperature _____ °C/ °F

Ambient pressure _____ mbar/ psi

	Data sheets	enclosed	not enclosed
Fluid transported	<input type="checkbox"/>	<input type="checkbox"/>	<input type="checkbox"/>
Ambient medium	<input type="checkbox"/>	<input type="checkbox"/>	<input type="checkbox"/>

climatherm – Advantages and fields of application

The climatherm-pipe system has been developed especially for applications outside the potable water installation.

In addition to the general advantages of the PP-R pipe system (see page 11) climatherm in comparison with the fusiotherm®-system offers higher volumetric current values due to smaller wall thickness.

The dimensions range from 20 mm to 160 mm and also 200 and 250 mm external diameter.

The system includes all elements for the pipe system installation for chilled, hot fluid and various industrial applications.

Detailed advantages of climatherm and the material fusiolen® PP-R:

- absolutely corrosion resistant
- resistant against chemicals
- high environmental compatibility
- high impact rate
- less pipe roughness
- heat and soundinsulating characteristics
- very good welding properties
- high heat-stabilized
- noticeable less insulation - recommended are 10 mm of insulation for all pipe dimensions
- high stability
- lighter in weight
- easy processing
- well-priced
- installation aids and fixings

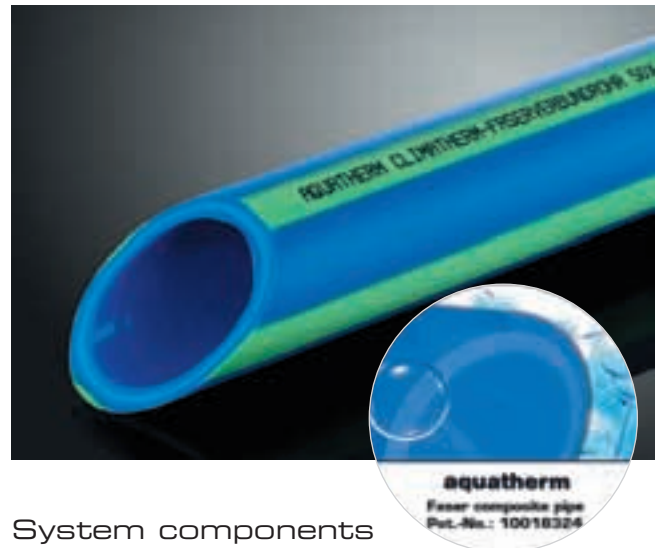

System components

The climatherm-pipe system has to be installed in combination with the fusiotherm®-fittings - and consists of:

- pipes in length and/ or coils
- fittings
- weldable flange adapter for flange connections
- armature connections and accessories
- transition pieces from PP-R to metal resp. metal to PP-R
- weld-in saddles
- manifolds
- shut-off devices
- welding devices, welding tools
- cutting tools
- auxiliaries and mountings



Features

Fields of application of the **fusiotherm**[®]- and **climatherm**-pipe systems:

System recommended due to its technical advantages: ●

Application of the system is suitable: ○

fusiotherm[®]

climatherm

Potable water application	●	
Heating system construction	○	●
Climate technology	○	●
Chilled water technology	○	●
Swimming-pool technology	●	●
Chemical transport due to high chemical resistance	●	●
Rainwater application	○	●
Irrigation	○	●
Compressed air systems	○	●
Under-floor-heating-systems	○	●
Fire protection sprinkler-systems		
Application in the field of ship building	●	●
Geothermal	●	●

Water content per meter by comparison

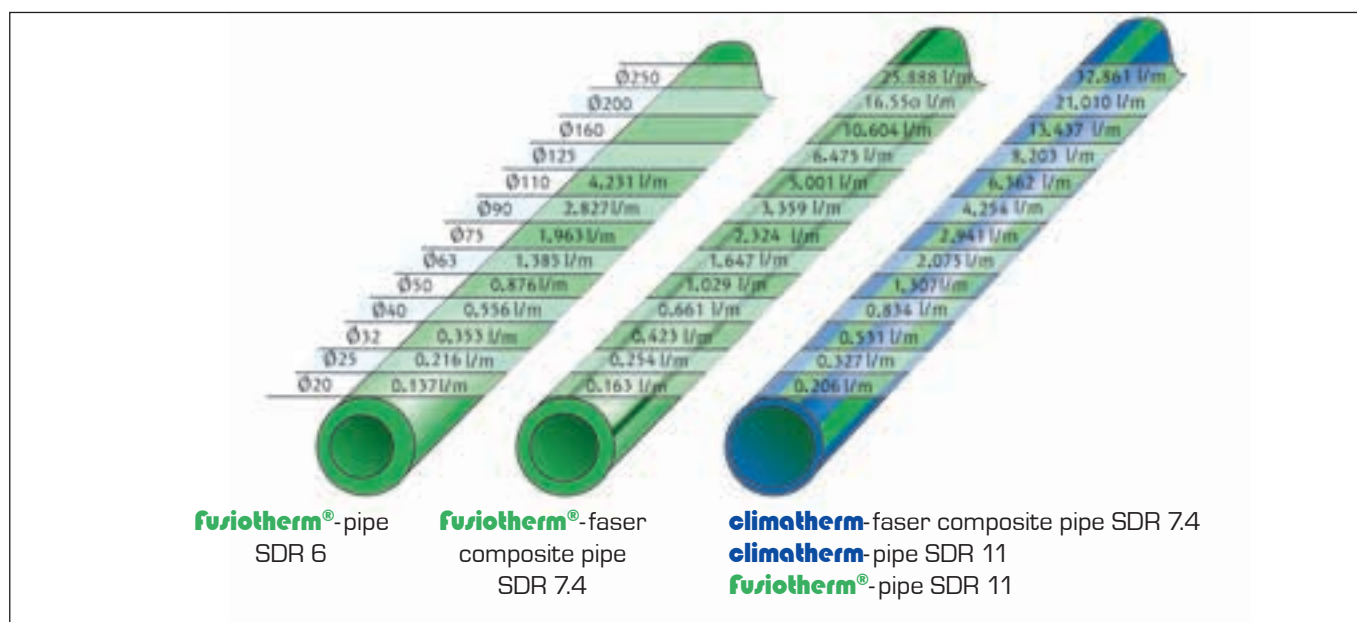

The specifications concerning the chemical resistance and the included inquiry are both listed in chapter 1, page 22 for the fusiotherm[®] and climatherm pipe system.

The conditions, regulations and recommendations, described in chapter 3 "fusion", chapter 4 "installation principles" and chapter 5 "planning" are also valid for fusiotherm[®] and the climatherm-pipes.

The fittings applied with the climatherm-pipe are specified in chapter 6 "product range".

In addition the same conditions of guarantee and delivery as for the other aquatherm-pipe systems are valid for the climatherm-pipes.

Chapter 2

Quality assurance

Quality assurance

The following laws, decrees, guidelines and standards have to be considered on planning and designing fusiotherm® for potable water and heating installations:*

Planning:

- ➡ TrinkwV-2000 Regulation for Potable Water
- ➡ EnEV Decree for Energy Saving
- ➡ DIN 1988 Standard for Potable Water Installations
- ➡ ISO 10508 Plastic pipe systems for hot and cold water installation – Guideline for classification and dimensioning

All provided pipe-systems correspond to the technical conditions of the application classes acc. to ISO 10508 for the field of potabel water and heating. fusiotherm® for the classes 1, 2 (potable water), climatherm for the classes 4 and 5 (heating). For the application of the classification system (acc. to ISO 10508) the national regulations and the manufacturer´s instructions must be considered.

- ➡ DIN 4109 Standard for the Elimination of Noise in the Field of Structural Engineering
- ➡ DIN 18381 VOB Part C Installation of Gas, Water and Sewage Pipes inside Buildings
- ➡ DIN 16928 Pipe Connections, Fittings, Installation
- ➡ DVS 2207 Welding of Thermoplastics
- ➡ DVS 2208 Welding Machines and Devices for Thermoplastics
- ➡ aquatherm Technical Information

Systemspecific standards:

General quality requirements, dimensions

- ➡ DIN 8077 Polypropylene (PP) Pipes, Dimensions
- ➡ DIN 8078 Polypropylene (PP) Pipes, General Quality Requirements
- ➡ DIN 16962ff Pipe Joint Assemblies and Fittings for Polypropylene Pressure Pipes
- ➡ DIN EN ISO 15874ff Plastic pipe systems for hot and cold water installation; polypropylene
- ➡ DVGW-Working sheets
- ➡ SKZ-Guidelines
- ➡ DIN EN ISO 9000 ff.

Systemspecific standards: Hygiene

➡ BfR Federal Institute for risk assignment

Health assessment of plastics and non-metallic materials within the framework of the law for foods and commodity goods for potable water applications

➡ DVGW-working sheet W 270

Increase of Microorganism on Materials. Used for Potable Water Applications – Test and Evaluation

➡ BS 6920

“Suitability of non-metallic products for use in contact with water intended for human consumption with regard to their effect on the quality of water.”

Local regulations and codes of practice must be observed. The same goes for regulations regarding the use of chemicals.

*{Additional regional decrees and recommendations are disregarded.}

Compliance with the system standard

Compliance with the system standard

Various national and international independent authorities and institutions confirm aquatherm's quality standard



aquatherm quality management system

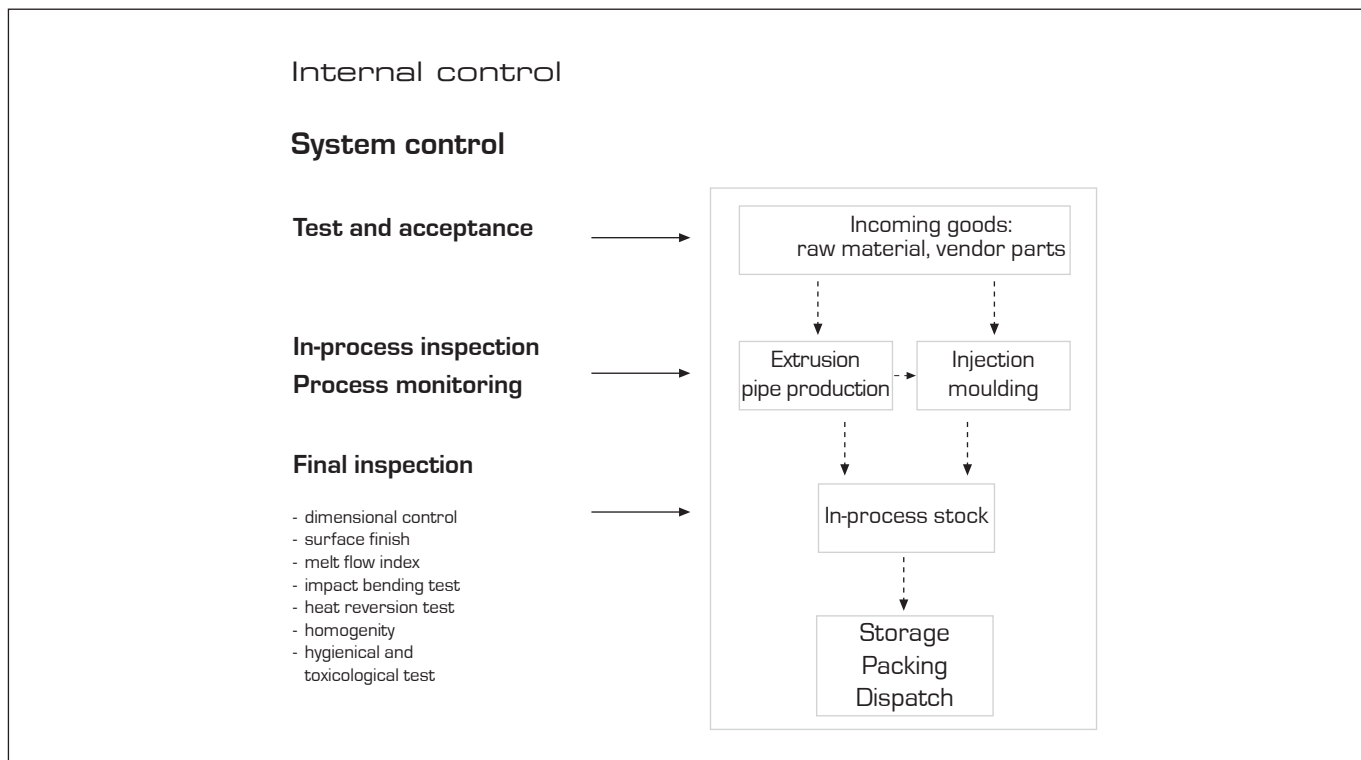

In addition to the permanent internal quality control, an external control is made by i.e. SKZ, SAI, TGM, Hygieneinstitut.

System control / Internal control

System control

The production of a quality controlled pipe system demands the supervision, regulation and control of all work operations. All results and processes have to be documented.

This requires

- test and acceptance of incoming goods
- process control
- in-process inspection and test
- final inspection and test

Relevant regulations for the quality control of potable water pipe systems are:

- DIN-guidelines
- DVGW-working sheets
- Supervisory Regulations of the SKZ
(Süddeutsches Kunststoff-Zentrum)

These standards and guidelines detail the minimum requirements for internal control.

Conformance to the standards is verified by independent institutes in form of internal audits and laboratory tests.

aquatherm has many years of experience in extrusion and injection moulding and is the market leader and pioneer in the manufacture of polypropylene pipe systems.

This experience is reflected in internal quality standards and laid down procedures, which are taken strongest note of and are documented by the constant quality of our products.

Internal control

Trained and qualified employees and a modern equipped laboratory ensure that all tests are carried out and regulations are complied with in accordance with the quality control policy, which includes

- control of inspection, measuring and test equipment
- process and production control
- receiving inspection test
- in-process inspection
- final inspection

All internal quality controls are documented and recorded in acc. with the quality control policy.



Quality assurance

Test and acceptance of incoming goods

All incoming goods are subject to a test. This ensures that incoming products conform to specified requirements. Goods, which have not been tested are not released for production.

In-process inspection and test

The quality plan requires that tests and inspections are carried out before and during production. At the start of production all quality relevant data are checked by the quality assurance department. Preproduction samples are tested by the laboratory technicians for

- surface finish
- dimensional accuracy of the test samples
- data from extrusion and injection moulding machines

The goods will be released for production only if optimal test results are achieved. These tests are carried out at the beginning of each production series to ensure perfect system quality.

Process control

Ultrasonic measurement and process data recording in the field of extrusion are only one example of the extensive quality control process.

This equipment enables constant observation and control of production.

Ultrasonics automatically measure and report any deviations in tolerance to the cutting device on the extrusion machine so that the sizing plant automatically isolates a substandard product. This ensures that only perfect quality products are packed and stored.

All data received during production is analyzed in detail.

Final inspection and test

The quality plan requires that inspections and tests are carried out on all finished products. The results are documented in test reports. Finished products are only released to stock when all tests and inspections conform to the prescribed procedures and specifications.

The final inspection and test includes time lapse test procedures. This enables statements regarding the usability of the products in their later field of application.

These tests are the method for quality assurance during production and for design tests. This is to discover and remove production weaknesses. The results document the system quality and optimize the manufacturing processes. The final inspection and test covers the following test procedures:

- Dimensional control
- Surface finish
- Measurement of the melt flow index
- Impact bending test
- Heat reversion test
- Homogeneity of the material
- Internal pressure test

In addition to the tests mentioned above, daily hygiene tests in accordance with KTW/DVGW Guidelines are carried out regularly in the company's own sensory analysis laboratory.



Quality assurance

External control

External supervision consists of tests of a defined scope and in defined intervals. The respective supervising institutions appoint authorized test organizations to carry out these tests.

The external supervision includes external tests of the products and

- a) internal audit of aquatherm's quality assurance system and test procedures,
- b) calibration of the test equipment and
- c) hygienic and toxicity tests.

The results of the supervisory visits as well as external tests made on pipe and fitting samples are confirmed to aquatherm in test certificates.

In Germany, the external supervision of the fusiotherm®-pipe system is carried out by the

- SKZ (Süddeutsches Kunststoffzentrum Würzburg)
- Institute for Hygiene, Gelsenkirchen (Hygieneinstitut Gelsenkirchen)

who are authorized by the DVGW (German Institute for Gas and Water) as controlling organization. The external supervision for certificates from abroad is carried out in a similar way.

Storage / packing / dispatch

Upon successful release the products are stored in suitable warehouses.

Internal instructions control the method of packing, storage and dispatch of the products. The warehouse staff is responsible for control of the stored product.



Test certificates



DVGW-Baumusterprüfzertifikat
DVGW type examination certificate
DW-601A82128

Anwendungsbereich: Produkte der Wasserverteilung
Zertifizierter Hersteller: Aquatherm GmbH Kunststoff- Extrusion- und Spritzgießtechnik
Produkt: Installationsarme und Systemarmaturen
Modell: FUSCHNER

Prüfberichte: Nachprüfung: 148700-0-148700 vom 03.04.2004 (BAZ)
Nachprüfung: 148700-0-148700 vom 03.04.2004 (BAZ)
Nachprüfung: 148700-0-148700 vom 03.04.2004 (BAZ)
Nachprüfung: 148700-0-148700 vom 03.04.2004 (BAZ)
Nachprüfung: 148700-0-148700 vom 03.04.2004 (BAZ)
Nachprüfung: 148700-0-148700 vom 03.04.2004 (BAZ)

Prüfungsort: DVGW W 844 (01.06.1999)
DVGW W 844 (01.06.1999)
DVGW W 844 (01.06.1999)
DVGW W 844 (01.06.1999)

Abgabetermin / AZ: 14.02.2010 / 01-0820-WW



DVGW-Baumusterprüfzertifikat
DVGW type examination certificate
DW-601A12224

Anwendungsbereich: Produkte der Wasserverteilung
Zertifizierter Hersteller: Aquatherm GmbH Kunststoff- Extrusion- und Spritzgießtechnik
Produkt: Installationsarme und Systemarmaturen
Modell: FUSCHNER

Prüfberichte: Nachprüfung: 148700-0-148700 vom 03.04.2004 (BAZ)
Nachprüfung: 148700-0-148700 vom 03.04.2004 (BAZ)
Nachprüfung: 148700-0-148700 vom 03.04.2004 (BAZ)
Nachprüfung: 148700-0-148700 vom 03.04.2004 (BAZ)
Nachprüfung: 148700-0-148700 vom 03.04.2004 (BAZ)
Nachprüfung: 148700-0-148700 vom 03.04.2004 (BAZ)

Prüfungsort: DVGW W 844 (01.06.1999)
DVGW W 844 (01.06.1999)
DVGW W 844 (01.06.1999)
DVGW W 844 (01.06.1999)

Abgabetermin / AZ: 05.08.2009 / 04-0209-WW



ZERTIFIKAT K Südwestliches Kunststoff-Zentrum

Certificate
The Südwestliches Kunststoff-Zentrum awards the following company:

Aquatherm GmbH
Kunststoff- Extrusion- u. Spritzgießtechnik
Friedenauer Straße 82
51430 Altdorf

A 175
for the following plastic products:
Pressure pipes made of PP-R 80
Production group 1 and 2

Users of the SKZ sign are obliged to observe the required regulations for the production and testing of these products.

Wittsburg, 17th August, 2000

K. K. K.  **K. K. K.**
Institute Director Head of the Department

Separation for information purposes only. The German certificate is authoritative.



ZERTIFIKAT K Südwestliches Kunststoff-Zentrum

Certificate
The Südwestliches Kunststoff-Zentrum awards the following company:

Aquatherm GmbH
Kunststoff- Extrusion- u. Spritzgießtechnik
Friedenauer Straße 82
51430 Altdorf

A 314
for the following plastic products:
Fiber composite pipes made of PP-R 80 / PP-R 80-GF / PP-R 80
Production group 1 and 2

Users of the SKZ sign are obliged to observe the required regulations for the production and testing of these products.

Wittsburg, 27th July, 2000

K. K. K.  **K. K. K.**
Institute Director Head of the Department

Separation for information purposes only. The German certificate is authoritative.

Chapter 3

Fusion

for **fusiotherm**[®] and **climatherm**

Part A: Mounting of the tools

1. **fusiotherm®** and **climatherm** are processed identically.

IMPORTANT!

Only use original fusiotherm®-welding devices and fusiotherm®-welding tools.

2. Assemble and tighten the cold welding tools manually.
3. Before fusing the distribution block, in which two connections are fused simultaneously, the welding tools have to be placed into the respective holes as described in the adjoining table A and drawing B.
4. All welding tools must be free from impurities. Check if they are clean before assembling. If necessary clean the welding tools with a non fibrous, coarse tissue and with methylated spirit.



A

Art.-No.	Passage	Hole	Branch	Hole
30115	Ø 25 mm	A + E	Ø 20 mm	A + C
85123	Ø 20 mm	A + B	Ø 16 mm	A + C
85124	Ø 20 mm	A + B	Ø 16 mm	A + C

B

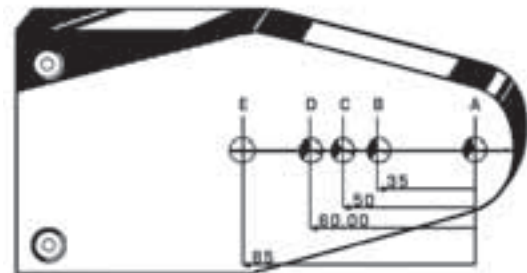

5. Place the welding tools on the welding device so that there is full surface contact between the welding tool and the heating plate. Welding tools over Ø 40 mm must always be fitted to the rear position of the heating plate.

Electric supply:

The power supply must coincide with the data on the type plate of the welding device and must be protected according to the local regulations. To avoid high power loss, the conductor cross-section of the used extension cables must be selected according to the power input of the welding devices.

6. Plug in the welding device. Depending on the ambient temperature it takes 10-30 minutes to heat up the heating plate.

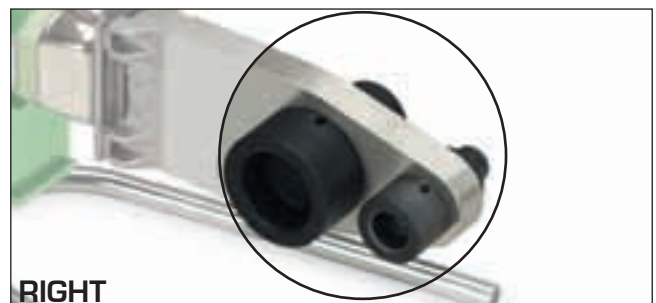

Part A: Heating up phase / Handling

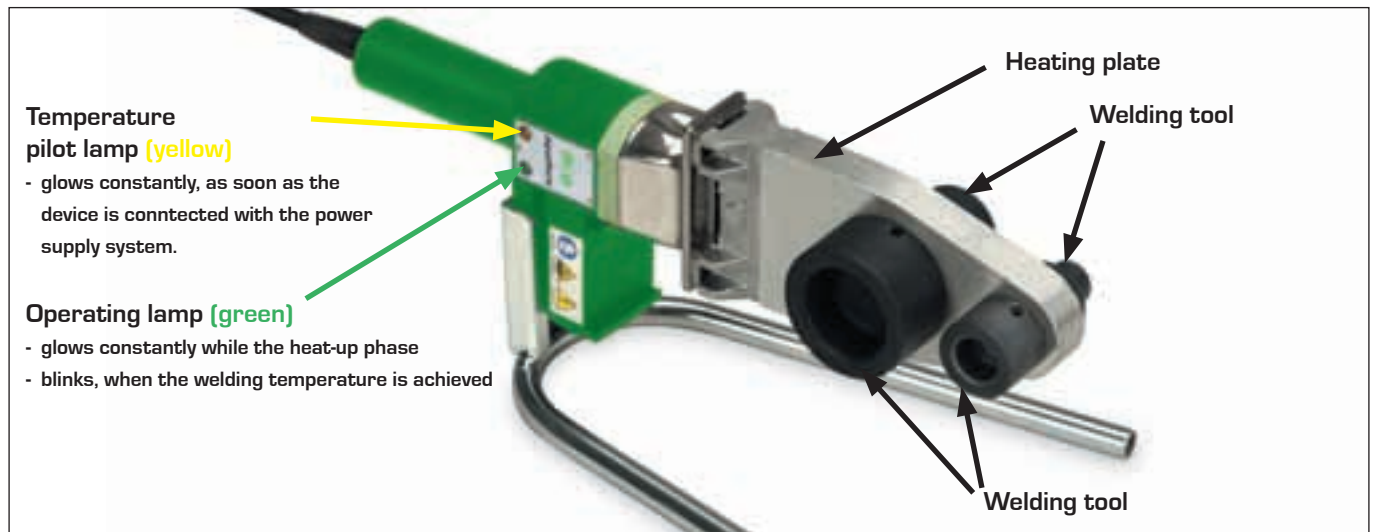

Part A: Heating up phase

7. During the heating up phase tighten the welding tools carefully with the Allan key.

Take care that the tools completely contact the heating plate. Never use pliers or any other unsuitable tools, as this will damage the coating of the welding tools.

8. The temperature of 260° C is required for the welding of the fusiotherm®-system.

Acc. to DVS-Welding Guidelines the temperature of the welding device has to be checked at its tool before starting the welding process.

This can be done with a fast indicating surface thermometer.

ATTENTION:

First welding - soonest 10 minutes after reaching of the welding temperature. DVS 2207, Part 11.

Part A: Handling

9. A tool change on a heated device requires another check of the welding temperature at the new tool (after its heating up).

10. If the device has been unplugged, e.g. during longer breaks, the heating up process, has to be restarted (see item 6).

11. After use unplug the welding device and let it cool down. Water must never be used to cool the welding device, as this would destroy the heating resistances.

12. Protect fusiotherm®-welding devices and tools against impurities. Burnt particles may lead to an incorrect fusion. The tools may be cleaned with fusiotherm®-cleansing cloths, Art.-No.50193.

Always keep the welding tools dry.

13. After welding, do not lay the the device on the Teflon-coated tool, but put it down in the provided supporting stand.

14. For a perfect fusion, damaged or dirty welding tools must be replaced, as only impeccable tools guarantee a perfect connection.

15. Never attempt to open or repair a defective device. Return the defective device for repair.

16. Check the operating temperature of fusiotherm®-welding devices regularly by means of suitable measuring instruments.

Part A: Guidelines

Part B: Checking of devices and tools

Part A: Guidelines

17. For the correct handling of welding machines the following must be observed:

General Regulations for Protection of Labour and Prevention of Accidents

and particularly the

Regulations of the Employers' Liability Insurance Association of the Chemical Industry regarding Machines for the Processing of Plastics, chapter: „Welding Machines and Welding Equipment“.

18. For the handling of fusiotherm®-welding machines, devices and tools please observe General Regulations DVS 2208 Part 1 of the German Association for Welding Engineering, Registered Society (Deutscher Verband für Schweißtechnik e. V.).

Part B: Checking of devices and tools

1. Check, if the fusiotherm®-welding devices and tools comply with to the guidelines "Fusion Part A".
2. All used devices and tools must have reached the necessary operating temperature of 260 °C. This requires acc. to "Fusion Part A, item 8" a separate test, which is indispensable (DVS-Welding Guidelines):

Suitable measuring instruments have to measure a temperature of up to 350° C with a high accuracy.



Temperature control with a thermometer

Part B: Preparation for the fusion

Part B: Preparation for the fusion

3. Cut the pipe at right angles to the pipe axis. Only use fusiotherm®-pipe cutters or other suitable cutting pliers. Take care that the pipe axis is free from burrs or cutting debris and remove where necessary.
4. Mark the welding depth at the end of the pipe with the enclosed pencil and template.
5. Mark the desired position of the fitting on the pipe and/or fitting.

The markings on the fitting and the uninterrupted line on the pipe may be used as a guide.

6. If stabi composite pipe is used, peel off the aluminium-polypropylene layer completely before.
7. Only use original fusiotherm®-peeling tools with undamaged peeling blades. Blunt peeling blades have to be replaced by original ones. It will be necessary to make trial peelings to check the correct setting of the new blade. It should not be easier than usual to push the peeled stabi composite pipe or PP-stabi pipe into the welding tool.
8. Push the end of the stabi composite pipe into the guide of the peeling tool. Peel off the aluminium-PP-composite layer up to the stop of the peeling tool. It is not necessary to mark the welding depth as the stop of the peeling tool indicates the correct welding depth.
9. Before starting the fusion, check if the aluminium-PP-composite layer has been completely removed.



Cutting of the pipe



Marking of the welding depth



Peeling of the aluminium-PP-composite-layer
(Necessary only for stabi-composite pipes!)

Part B: Preparation for the fusion / Heating of pipe and fitting

Part B: Preparation for the fusion

The fusion is subject to the following data

Pipe external-Ø	Welding depth	Heating time		Welding time	Cooling time
		sec. DVS	sec. AQE*		
mm	mm			sec.	min.
16	13.0	5	8	4	2
20	14.0	5	8	4	2
25	15.0	7	11	4	2
32	16.5	8	12	6	4
40	18.0	12	18	6	4
50	20.0	18	27	6	4
63	24.0	24	36	8	6
75	26.0	30	45	8	8
90	29.0	40	60	8	8
110	32.5	50	75	10	8
125	40.0	60	90	10	8

* heating times recommended by aquatherm at ambient temperatures below + 5 °C

Dimension 160, 200 + 250:

The dimension 160, 200 + 250 mm are joined by butt-welding.

Detailed information 51 + 52.

The General Guidelines for Heated Tool Socket Welding acc. to DVS 2207 Part 11 are applied hereupon.

Part B: Heating of pipe and fitting

10. Push the end of the pipe, without turning, up to the marked welding depth into the welding tool.

It is essential to observe the above mentioned heating times.

Pipes and fittings of the dimensions Ø 75 to 125 mm can only be welded with welding device Art.-No. 50141 (or with machine Art.-No. 50147). On using the fusiotherm®-welding machine Art.-No. 50147 a separate operating instruction has to be observed.



Heating-up of pipe and fitting

ATTENTION:

The heating time starts, when pipe and fitting have been pushed to the correct welding depth on the welding tool. **NOT BEFORE!**

Part B: Setting and alignment

Part C: Weld-in saddles

Part B: Setting and alignment

11. After the required heating time quickly remove pipe and fitting from the welding tools. Joint them immediately, and without turning, until the marked welding depth is covered by the PP-bead from the fitting.

ATTENTION:

Do not push the pipe too far into the fitting, as this would reduce the bore and in an extreme case will close the pipe.

12. The joint elements have to be fixed during the specified assembly time. Use this time to correct the connection. Correction is restricted to the alignment of pipe and fitting. Never turn the elements or align the connection after the processing time.

13. After the required cooling time the fused joint is ready for use.

The result of the fusion of pipe and fitting is a permanent material joining of the system elements. Connection technique with security for a life-time.

Part C: Weld-in saddles

fusiotherm®-weld-in saddles are available for pipe outer diameter of 40, 50, 63, 75, 90, 110, 125, 160, 200 and 250 mm.

Weld in saddles are used for

- branch connections in existing installations
- the substitution of a reduction-tee
- branch connections in risers
- sensor wells, etc.

The maximum sensor well diameter is specified in the following table.



Joining, fixing and...



...aligning



The result: a permanent connection!

Part C: Weld-in saddles

Art.-No.	Dimension	D	d	l	Borer	Chamfering Device*	Tool
		mm	mm	mm	Art.-No.	Art.-No.	Art.-No.
15156	40/20 mm	40	25	27.0	50940	50910	50614
15158	40/25 mm	40	25	28.0	50940	50910	50614
15160	50/20 mm	50	20	27.0	50940	50910	50616
15162	50/25 mm	50	25	28.0	50940	50910	50616
15164	63/20 mm	63	20	27.0	50940/15941	50910	50619
15166	63/25 mm	63	25	28.0	50940/15941	50910	50619
15168	63/32 mm	63	32	30.0	50942	50912	50620
15170	75/20 mm	75	20	27.0	50940/15941	50910	50623
15172	75/25 mm	75	25	28.0	50940/15941	50910	50623
15174	75/32 mm	75	32	30.0	50942	50912	50624
15175	75/40 mm	75	40	34.0	50944	50914	50625
15176	90/20 mm	90	20	27.0	50940/15941	50910	50627
15178	90/25 mm	90	25	28.0	50940/15941	50910	50627
15180	90/32 mm	90	32	30.0	50942	50912	50628
15181	90/40 mm	90	40	34.0	50944	50914	50629
15182	110/20 mm	110	20	27.0	50940/15941	50910	50631
15184	110/25 mm	110	25	28.0	50940/15941	50910	50631
15186	110/32 mm	110	32	30.0	50942	50912	50632
15188	110/40 mm	110	40	34.0	50944	50914	50634
15189	110/50 mm	110	50	34.0	50946	-	50635
15190	125/20 mm	125	20	27.0	50940/15941	-	50636
15192	125/25 mm	125	25	28.0	50940/15941	-	50636
15194	125/32 mm	125	32	30.0	50942	-	50638
15196	125/40 mm	125	40	34.0	50944	-	50640
15197	125/50 mm	125	50	34.0	50946	-	50642
15198	125/63 mm	125	63	38.0	50948	-	50644
15206	160/20 mm	160	20	27.5	50940/15941	-	50648
15208	160/25 mm	160	25	28.5	50940/15941	-	50648
15210	160/32 mm	160	32	30.0	50942	-	50650
15212	160/40 mm	160	40	34.0	50944	-	50652
15214	160/50 mm	160	50	34.0	50946	-	50654
15216	160/63 mm	160	63	38.0	50948	-	50656
15228	200-250/20 mm	200-250	20	27.5	50941	-	50660/50672
15229	200-250/25 mm	200-250	25	28.5	50941	-	50660/50672
15230	200-250/32 mm	200-250	32	30	50942	-	50662/50674
15231	200/40 mm	200	40	34	50944	-	50664
15232	200/50 mm	200	50	34	50946	-	50666
15233	200/63 mm	200	63	37.5	50948	-	50668
15251	250/40 mm	250	40	34	50944	-	50676
15252	250/50 mm	250	50	34	50946	-	50678
15253	250/63 mm	250	63	37.5	50948	-	50680

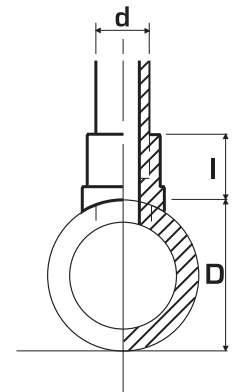

* only for stabi-composite-pipes Art.-No. 70806-70824

Part C: Weld-in saddles

Art.-No.	Dimension	D	R	I	Sensor-welds	Borer	Chamfering Device*	Tool
		mm	f	mm	ø mm	Art.-No.	Art.-No.	Art.-No.
28214	40/25 x 1/2" f	40	1/2"	39.0	14	50940	50910	50614
28216	50/25 x 1/2" f	50	1/2"	39.0	14	50940	50910	50616
28218	63/25 x 1/2" f	63	1/2"	39.0	14	50940/15941	50910	50619
28220	75/25 x 1/2" f	75	1/2"	39.0	14	50940/15941	50910	50623
28222	90/25 x 1/2" f	90	1/2"	39.0	14	50940/15941	50910	50627
28224	110/25 x 1/2" f	110	1/2"	39.0	14	50940/15941	50910	50631
28226	125/25 x 1/2" f	125	1/2"	39.0	14	50940/15941	-	50636
28230	160/25 x 1/2" f	160	1/2"	39.0	14	50940/15941	-	50648
28232	200-250/25 mm x 1/2" f	200-250	1/2"	39.0	14	50941	-	50660 / 50672
28234	40/25 x 3/4" f	40	3/4"	39.0	16	50940	50910	50614
28236	50/25 x 3/4" f	50	3/4"	39.0	16	50940	50910	50616
28238	63/25 x 3/4" f	63	3/4"	39.0	16	50940/15941	50910	50619
28240	75/25 x 3/4" f	75	3/4"	39.0	16	50940/15941	50910	50623
28242	90/25 x 3/4" f	90	3/4"	39.0	16	50940/15941	50910	50627
28244	110/25 x 3/4" f	110	3/4"	39.0	16	50940/15941	50910	50631
28246	125/25 x 3/4" f	125	3/4"	39.0	16	50940/15941	-	50636
28250	160/25 x 3/4" f	160	3/4"	39.0	16	50940/15941	-	50648
28254	200-250/25 mm x 3/4" f	200-250	3/4"	39.0	16	50941	-	50660 / 50672
28260	75/32 x 1" f	75	1"	43.0	20	50942	50912	50624
28262	90/32 x 1" f	90	1"	43.0	20	50942	50912	50628
28264	110/32 x 1" f	110	1"	43.0	20	50942	50912	50632
28266	125/32 x 1" f	125	1"	43.0	20	50942	-	50638
28270	160/32 x 1" f	160	1"	43.0	20	50942	-	50650
28274	200-250/32 mm x 1" f	200-250	1"	43.0	20	50942	-	50662 / 50674

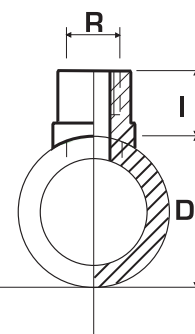

Art.-No.	Dimension	D	R	I	Borer	Chamfering Device*	Tool
		mm	m	mm	Art.-No.	Art.-No.	Art.-No.
28314	40/25 x 1/2" m	40	1/2"	55.0	15940	50910	50614
28316	50/25 x 1/2" m	50	1/2"	55.0	15940	50910	50616
28318	63/25 x 1/2" m	63	1/2"	55.0	15940/15941	50910	50619
28320	75/25 x 1/2" m	75	1/2"	55.0	15940/15941	50910	50623
28322	90/25 x 1/2" m	90	1/2"	55.0	15940/15941	50910	50627
28324	110/25 x 1/2" m	110	1/2"	55.0	15940/15941	50910	50631
28326	125/25 x 1/2" m	125	1/2"	55.0	15940/15941	-	50636
28330	160/25 x 1/2" m	160	1/2"	55.0	15940/15941	-	50648
28334	40/25 x 3/4" m	40	3/4"	56.0	15940	50910	50614
28336	50/25 x 3/4" m	50	3/4"	56.0	15940	50910	50616
28338	63/25 x 3/4" m	63	3/4"	56.0	15940/15941	50910	50619
28340	75/25 x 3/4" m	75	3/4"	56.0	15940/15941	50910	50623
28342	90/25 x 3/4" m	90	3/4"	56.0	15940/15941	50910	50627
28344	110/25 x 3/4" m	110	3/4"	56.0	15940/15941	50910	50631
28346	125/25 x 3/4" m	125	3/4"	56.0	15940/15941	-	50636
28350	160/25 x 3/4" m	160	3/4"	56.0	15940/15941	-	50648

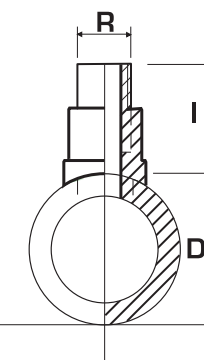

* only for stabi-composite-pipes Art.-No. 70806-70824

Part C: Weld-in saddles

Part C: Weld-in saddles

1. Before starting the welding process, check whether the fusiotherm®-welding devices and tools comply with the requirements of "Fusion Part A".
2. The first step is to drill through the pipe wall at the intended outlet point by using the fusiotherm®-drill.

- branch 20 / 25 mm: Art.-No. 50940 / 50941
- branch 32 mm: Art.-No. 50942
- branch 40 mm: Art.-No. 50944
- branch 50 mm: Art.-No. 50946
- branch 63 mm: Art.-No. 50948

3. When using fusiotherm®-stabi composite pipes remove the rest of the aluminium remaining at the bore hole with the fusiotherm®-chamfering device.

- branch 20 / 25 mm: Art.-No. 50910
- branch 32 mm: Art.-No. 50912
- branch 40 mm: Art.-No. 50914

4. The welding device / saddle welding tool must have reached the required operating temperature of 260 °C (check with reference to "Fusion Part B, item 2").
5. The welding surfaces have to be clean and dry.
6. Insert the heating tool on the concave side of the weld-in saddle tool into the hole drilled in the pipe wall until the tool is completely in contact with the outer wall of the pipe. Next the weld-in saddle tool is inserted into the heating sleeve until the saddle surface is up against the convex side of the welding tool. The heating time of the elements is generally 30 seconds.
7. After the welding tool has been removed, the weld-in saddle tool is immediately inserted into the heated, drilled hole. Then the weld-in saddle should be pressed on the pipe for about 15 seconds. After being allowed to cool for 10 minutes the connection can be exposed to its full loading. The appropriate branch pipe is fitted into the sleeve on the fusiotherm®-weld-in saddle using conventional fusion technology.

By fusing the weld-in saddle with the pipe outer surface and the pipe inner wall the connection reaches highest stability.



Drilling through the pipe wall



The welding tool is inserted into the pipe wall ...



...heating-up of the elements



Joining

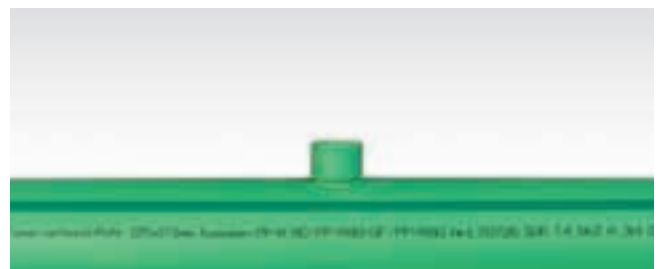

Ready!

Part D: Electrical welding jig

By means of the electrical welding jig, fusiotherm®-pipes and fittings in dimensions of between 63 and 125 mm can be welded in the easiest way without any effort, with considerable time saving compared to customary welding.

Another advantage of the welding jig is the simple welding of pipes and fittings under ceilings, in narrow shafts and in other hardly accessible places.

1. Preparation for the fusion

Mark the welding and clamping depth at the end of the pipe by using the attached blue template. (Illustration 1)

The welding jig is fixed with the clamping jaws at the pipe and fitting.

Secure the clamping jaws by means of the clamping fixtures.

Align the pipe that the back mark is precise with the inside edge of the clamping jaw. The front mark shows the welding depth (Illustration 2). Secure the pipe and fitting with the front setscrew. (Illustration 3+4)

1



2



3



4



Never overtighten the pipe for avoiding deformations.

Part D: Electrical welding jig

2. Fusion

Keep the welding device between pipe and fitting and drive the machine slide in batches. Mind the welding depth!

Basically after introducing of pipe and fitting to the welding tool, the clamping jaws are to be relieved by a short return of the machine! The clamping jaws must always be parallel. (Illustration 5+6)

After the end of the heating time, release the machine slide and remove the welding device. (Illustration 7)

Pull the clamping jaws with pipe and fitting together and relieve the clamping jaws by a short return of the machine. (Illustration 8)

NOTE:

Clamping jaws and screws must not be loosened before the end of the cooling time!

By fusion of pipe and fitting a permanent connection is made. (Illustration 9)



Pipe external	Welding depth	Heating time		Welding time	Cooling time
		sec. DVS	sec. ADE*		
63	24.0	24	36	8	6
75	26.0	30	45	8	8
90	29.0	40	60	8	8
110	32.5	50	75	10	8
125	40.0	60	90	10	8

Following DVS 2207 part 11: At outdoor temperatures below +5 °C heating time will be increase of about 50%!

*heating times recommended by aquatherm

The General Guidelines for Heated Socket Welding acc. to DVS 2207, Part 11 are applied hereupon.

Part E: **fusiotherm**[®]-welding machine

Part E: **fusiotherm**[®]-welding machine

One wooden transport box for the welding machine includes:

- One machine body with substructure, heating plate
- One set clamping jaws composed of 8 two-part jaws bars for pipes and fittings, outer diameter 25, 32, 40, 50, 63, 75, 90, 110, 125 mm
- One fusiotherm[®]-welding tool diameter 50, 63, 75, 90, 110, 125 mm
- One welding device Art.-No.: 50341
- One Allan key and tool change clamp
- One Installation manual



The fusiotherm[®]-welding machine was specially developed for stationary welding of pipe and fittings with an external diameter of 50 to 125 mm. This machine is equipped with a hand crank to facilitate a precise pre-assembly of complicated installation parts.

The necessary operating instructions are enclosed.



The fusion is subject to the following data

Pipe external-Ø	Welding depth	Heating time		Welding time	Cooling time
		sec. DVS	sec. AQE*		
50	20.0	18	27	6	4
63	24.0	24	36	8	6
75	26.0	30	45	8	8
90	29.0	40	60	8	8
110	32.5	50	75	10	8
125	40.0	60	90	10	8

*heating times recommended by aquatherm at ambient temperatures below + 5 °C

Dimension 160, 200 + 250 mm:

The dimension 160, 200 + 250 mm are joined by butt-welding.

Detailed information in this chapter on page 51 + 52.

The general guidelines for heated tool socket welding acc. to DVS 2207 part 11 are applied hereupon.

Part F: **fusiotherm**[®]-electrofusion device

Part F: **fusiotherm**[®]-electrofusion device

Fusion

The fusiotherm[®]-electrofusion device was specially developed for electrofusion sockets from Ø 20 - 160 mm.

The fusion of 160 mm **fusiotherm**[®]- and **climatherm**-faser composite pipes UV-resistant with the electrofusion socket Art.-No. 17230 is not possible.

Technical information:

- supply voltage: 230 V (nominal voltage)
- nominal capacity: 2.800 VA, 80 % ED
- rated frequency: 50 Hz - 60 Hz
- protection class: IP 54

1. General and inspection

Cleanliness is - besides correct workmanship - the most important precondition for a correct fusion. For keeping the sockets clean do not unwrap them before processing.

The pipe surface must also be clean and undamaged. Deformed pipe ends must be cut off.

All parts of the system to be fused as well the temperature sensors shall have the same temperature (e.g. sun radiation or unadapted storing may cause differences in temperature!) within the acceptable range of temperature (e.g. +5 °C to 40 °C according to DVS 2207).

2. Preparation

Follow carefully the order of working steps!

Preparation is one of the most important steps of the electrofusion process!

1. Cut the ends of the pipes rectangularly and deburr them thoroughly
2. Clean and dry the ends of the pipes at the necessary length
3. Mark the depth of fusiotherm[®]- electro-fusion-socket on the end of the pipe



fusiotherm[®]-electrofusion device Ø 20-160 mm



fusiotherm[®]-electrofusion socket



fusiotherm[®]-peeling tool (Art.-No. 50558-70, up to 75 mm) (from 90-160 mm: Art.-No. 50572/50574/50576/ 50580 (without picture))

Welding depth up to 160 mm											
Ø	20	25	32	40	50	63	75	90	110	125	160
depth	35.0	39.0	40.0	46.0	51.0	59.0	65.0	72.5	80.0	86.0	93.0

Part F: **fusiotherm**[®]-electrofusion device

Part F: **fusiotherm**[®]- electrofusion device

Fusion

4. Peel the surface of both pipes up to the marks thoroughly with a peeling tool (use the fusiotherm[®]-peeling tool with the respective pipe diameter)
5. Clean again thoroughly

Without complete peeling of the fusion surface a homogeneous and tight welding connection is not assured. Damages of the surface like axial grooves and scratches are not accepted in the fusion zone. Never touch peeled surfaces and protect them against dirt and grease. Start the fusion process within 30 mins after peeling.

3. Assembling the **fusiotherm**[®] electrofusion sockets

Avoid soiling and fix all parts securely!

1. Open the protective wrapping of the fusiotherm[®]-electrofusion sockets (cut with knife along the edge of the bore), leaving the rest of the foil intact. Clean the inside of the fitting carefully with aquatherm[®]-cleaning wipes. Assemble the fitting within 30 mins after opening of the protective foil.
2. Push the fusiotherm[®]-electrofusion sockets on the clean and dry end of the pipe (up to the marked depth). Use pressing clamps if necessary.
3. Remove the protective foil completely and push the other prepared pipe end into the fusiotherm[®]-electrofusion sockets tighten in the fixation.

Leave the pipes, free from bending stress or own weight, within the fusiotherm[®]-electrofusion socket. the socket is movable at both pipe ends after assembling. The air gap has to be even around the circumference. A non stress-free, resp. displaced connection can effect an unacceptable melt-flow and a defective connection while joining. The pipe ends and electrofusion sockets have to be dry when installed.



Cut, peel and clean the pipes to be welded carefully



Clean the inner surface of the electrofusion socket



Push the electrofusion socket onto the pipe end



Part F: fusiotherm®-electrofusion device

Part F: fusiotherm®-electrofusion device

Fusion

4. Fusion process

1. Position the fitting with even air gap around the circumference.
2. Regulate fusion equipment for the right fusion parameter.
3. Compare the indications of the fusion equipment with the parameters of the label.
4. Start and watch the fusion process.

Do not move or stress pipe and fitting during the whole fusion process and cooling time.

5. Cooling time and pressure test

A fused pipe-joint shall not be moved (no release of the fixation) or stressed before complete cooling.

The minimum required cooling time is marked on each fusiotherm®-electrofusion socket. Ambient temperatures of more than 25 °C or strong sun-radiation need longer cooling times.

Working pressure

fusiotherm®-electrofusion sockets correspond to the pressure of PN 20. The relation between working temperature, pressure load and service life is given in the tables "Permissible working pressure."

For further information concerning electrofusion socket and details about the fusiotherm®-electrofusion device read the enclosed operating instructions.



Push the second pipe - also peeled and cleaned - into the socket

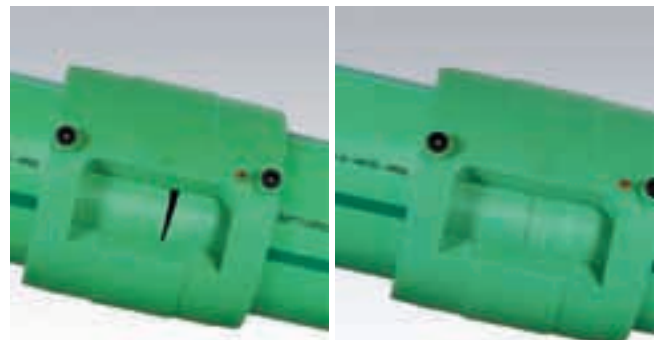

WRONG

RIGHT

For a stable welding result it is important that both pipe ends inside the electrofusion socket are with parallel faces! Follow the minimum welding depth - absolutely!



Adjust the socket diameter on the welding device. Start and control welding process. Keep the cooling time. Finished!

Kind of stress	Compressive stress	Minimum waiting period
Tension, bend, torsion of unpressurized pipes		20 minutes
Test- or working pressure of pipes pressurized	up to 0.1 bar [1.5 psi] 0.1 up to 1 bar [1.5-14.5 psi] over 1 bar [14.5 psi]	20 minutes 60 minutes 120 minutes
Repeating of the welding process		60 minutes

Part F: **fusiotherm**[®]-electrofusion device

Part G: Additional possibilities of repair

Part F: **fusiotherm**[®]-electrofusion device

Pipe repairs with the **fusiotherm**[®]-electrofusion socket

Cut squarely 3 to 4 lengths of a fitting out of the defect pipe, symmetrically to the defect. Fit the new pipe into this gap. Prepare the pipe ends of the existing pipe as in the case of a new welding.

Peel the new piece of pipe on both sides with the peeling tool on a length of more than the length of one fitting.

Unwrap two fittings and carefully move the fittings over both ends of the new pipe.

Then place the repair-pipe into the gap and move the fittings until they are aligned with the markings on the existing pipes.

Take care, that the fittings are exactly aligned and completely free of stress before welding.

Part G: Additional possibilities of repair

Damaged pipes may be repaired - as already mentioned - by means of

fusion (see Part B)
electrofusion socket (see Part F).

In addition to this the **fusiotherm**[®]-system offers the possibility of the

pipe repair stick.

The necessary welding tool (Art.-No. 50307 / 11) and repair stick (Art.-No. 60600) are described on page 164, 165 and 168.

The installation information is enclosed with the welding tool, but may also be ordered separately (Order-No. D 11450) from aquatherm.



Heat-up

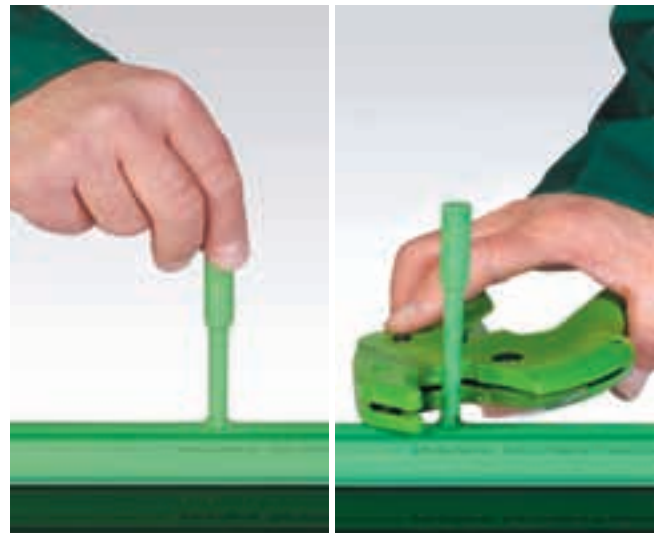

Repair stick

Cutting

Part H: Butt-welding of pipe dimension 160, 200 and 250 mm

Butt-welding of pipe dimension 160, 200 and 250 mm

The following fusiotherm®-pipes series are available:

fuviotherm®-pipe SDR 11 for cold water

fuviotherm®-faser-composite pipe SDR 7.4
 (Pat.-No. 10018324, trademark protection no. 39926599 for green/dark green)

climatherm-faser-composite pipe SDR 11

Pipes and fittings are fused, as explained below, by **butt welding**:

1. Protect your place of work from weather influences
2. Check, if welding machine works properly and heat it up
3. Cut pipes into required length
4. Plastic pipes are aligned and fixed by means of the clamping elements
5. Use the milling machine for planing the pipe end to be plane-parallel
6. Remove the debris and clean the pipe ends with methylated spirit
7. Check if pipes match
 (tolerance: max. 0.1 x wall thickness)
8. Check width of gap between the two pipes to be welded (tolerance: max. 0.5 mm)
9. Check the temperature of the heating element
 (210° C +/- 10° C)
10. Clean the heating element



Before welding, the 160, 200 or 250 mm pipes are cut into the required lengths



Check performance of the welding machine and heat it up

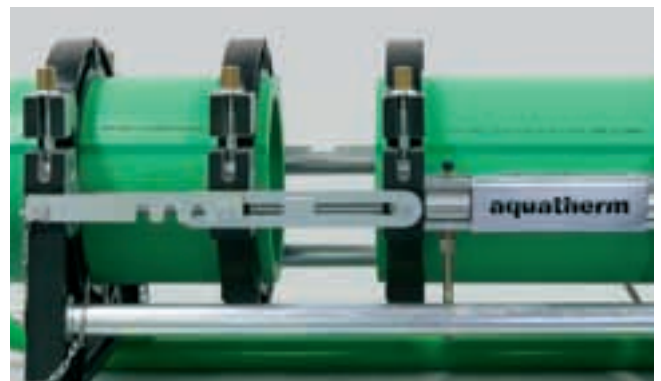

The parts to be welded are fixed and aligned respectively, the milling machine is used



Part H: Butt-welding of pipe dimension 160, 200 and 250 mm

11. After the heating element has been positioned, the pipes are pushed onto the heating plate with a defined adjusting pressure.

12. After reaching the specified bead height (see tablet) the pressure is reduced. This process marks the beginning of the heating time. This time is for heating up the pipe ends up to the right welding temperature.

Specified bead height in mm:

	SDR 7.4	SDR 11
160 mm	1.5	1.0
200 mm	2.0	1.0
200 mm	2.0	1.5

13. When heating time has expired, divide the machine slide, remove heating element quickly and join the pipes (by putting both parts of the slide together).

14. The pipes are fused with the required welding pressure and cooled down under pressure.

15. The welded connection can be unclamped - the welding process is finished.

Additionally please follow the instructions given in the operating manual of the welding machine and observe guideline DVS 2207, part 11.

Important Note

1. The welding machines have to be suitable for the welding of pipes with a diameter/wall thickness ratio of up to SDR 7.4

aquatherm recommends the following suitable welding machines for butt welding:

Company Ritmo: DELTA „DRAGON“250
 Company Rothenberger: ROWELD P 250 B
 Company Widos: WIDOS 4001 / 4002

2. For hydraulically operated welding machines, the real manometer pressure has to be calculated in consideration of the hydraulic piston area.

This value can be taken from the respective operating manuals.



Positioning of heating element



Divide the machine slide, remove heating element

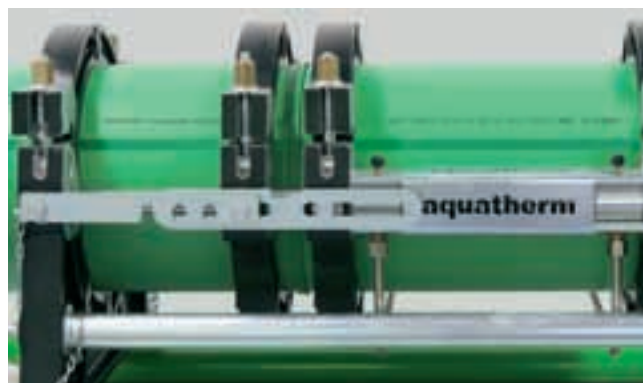

Join the pipes, cool down under pressure



Unclamp and work on...

Chapter 4

Installation principles

Fastening technique / Fixed points / Sliding points

Fastening technique

Pipe clamps for fusiotherm®-pipes must be dimensioned for the external diameter of the plastic pipe.

Take care, that the fastening material does not mechanically damage the surface of the pipe (fusiotherm®-pipe clamps Art.-No.: 60516-60597).

The ideal fastening material for fusiotherm®-pipes are rubber lined pipe clamps. The rubber compound is especially made for applications with plastic pipes.

Basically it must be distinguished on pipe assembly, whether the fastening material is used as

- a fixed point or
- a sliding point.

Fixed points

On locating fixed points the pipelines are divided into individual sections. This avoids uncontrolled movements of the pipe.

In principle fixed points have to be measured and installed in a way, that the forces of expansion of fusiotherm®-pipes as well as probable additional loads are accommodated.

On using threaded rods or threaded screws the drop from the ceiling should be as short as possible. Swinging clamps should not be used as fixed points.

Basically vertical distributions can be installed. Risers do not require expansion loops, provided that fixed points are located immediately before or after a branch.

To compensate the forces arising from the linear expansion of the pipe there must be sufficient and stable clamps and mountings.

fusiotherm®-pipe clamps meet all mentioned requirements and - when considering the following installation instructions - are perfect for fixed point installations.

Sliding points

Sliding clamps have to allow axial pipe movements without damaging the pipe.

On locating a sliding clamp it has to be ensured that movements of the pipelines are not hindered by fittings or armatures installed next to the clamps.

fusiotherm®-pipe clamps have an extra even and sliding surface of the sound insulation insert.

Installation advice / Linear expansion / Concealed installation

Installation advices

fusiotherm®-pipe clamps are perfectly suited for fixed point and sliding point installations.

The application of distance rings depends on the type of pipe.

Fastening	fusiotherm®-pipe fusiotherm®-faser composite pipe	fusiotherm®- stabi composite pipe
Sliding Point	1 distance ring	2 distance rings
Fixed point	no distance ring	1 distance ring

Linear expansion

The linear expansion of pipes depends on the difference of operating temperature to installation temperature:

$$\Delta T = T_{\text{operating temperature}} - T_{\text{installation temperature}}$$

Therefore cold water pipes have practically no linear expansion.

Because of the heat dependent expansion of the material, the linear expansion must especially be considered in case of hot and heating installations. This requires a distinction of the types of installation, e.g.

- ▣ concealed installation
- ▣ installation in ducts
- ▣ open installation.

Concealed installation

Concealed installations generally do not require a consideration of the expansion of fusiotherm®-pipes.

The insulation acc. to DIN 1988 or the EnEV (Energieeinsparverordnung) provides enough expansion space for the pipe. In the case where the expansion is greater than the room to move in the insulation, the material absorbs any stress arising from a residual expansion.

The same applies to pipes, which do not have to be insulated acc. to current regulations.

A temperature induced linear expansion is prevented by the embedding in the floor, concrete or plaster. The compressive strain and tensile stress arising from this are not critical as they are absorbed by the material itself.

Installation in ducts / fusiotherm[®]-pipe

Installation in ducts

Due to the different linear expansion of the fusiotherm[®]-pipes with or without stabilization, the installation of pipe branches in risers has to be made according to the selected type of pipe.

fusiotherm[®]-stabi/faser composite pipe

The linear expansion of fusiotherm[®]-stabi-composite pipes and fusiotherm[®]-faser composite pipes in vertical risers can be ignored.

The positioning of a fixed point directly before each branch-off point is sufficient. All clamps in the riser must be installed as fixed points (see 1).

In general it is possible to install risers rigidly, that means without expansion joints. This directs the expansion on the distance between the fixed points, where it is ineffective.

A maximum distance of 3.0 meters between two fixed points must be regarded.

fusiotherm[®]-pipe

The installation of risers of fusiotherm[®]-pipes without stabilizing components (aluminium or faser) requires a branch pipe, which is elastic enough to take the linear expansion of the riser.

- This can be ensured by a favourable fixing of the riser in the duct (see 2).
- An adequate large pipe liner also gives sufficient elasticity to the branch-off pipe (see 3).
- Furthermore the installation of a spring leg gives the appropriate elasticity (see 4).

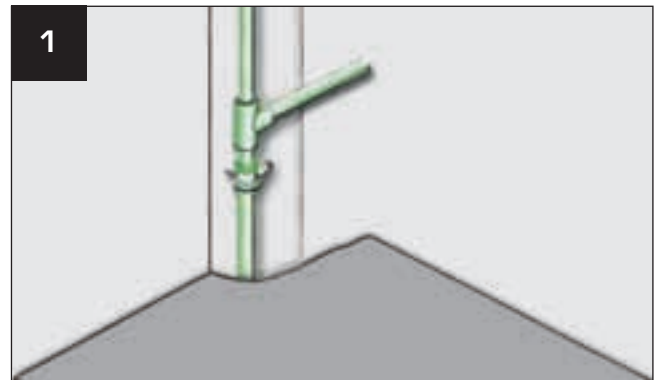

Positioning of the fixed point clamp

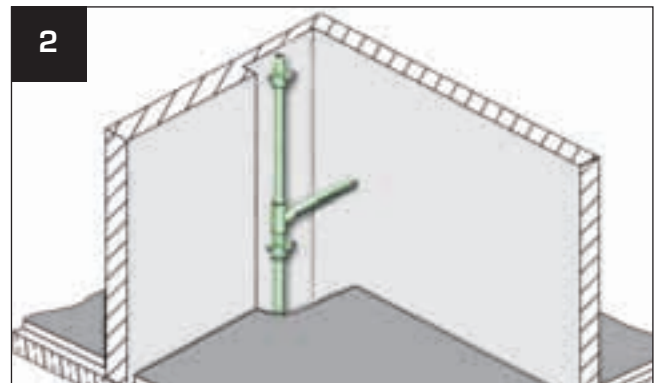

Favourable fixing

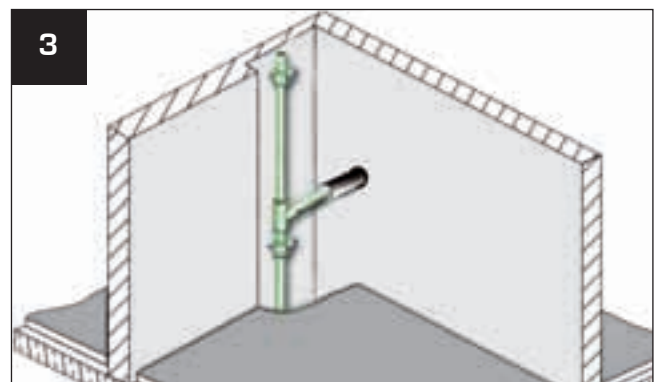

Large diameter pipe liner

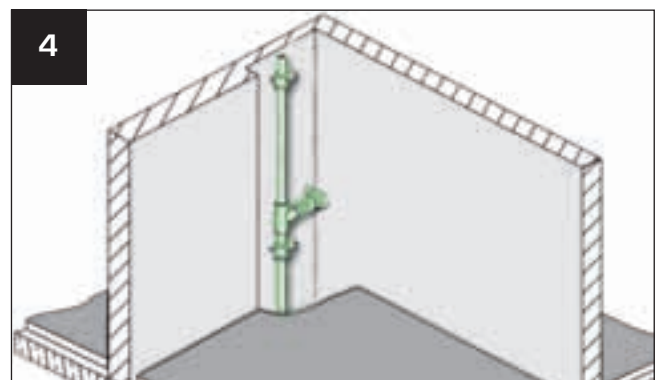

Installation of a spring leg

Open installation / Calculation of the linear expansion

Open installation

In case of open installed pipes (e.g. in the basement), excellent optical characteristics and form stability are important. fusiotherm®-pipes for cold water and fusiotherm®-stabi composite / faser composite pipes for hot water and heating plants make this possible. The coefficient (α) of linear expansion of fusiotherm®-composite pipes is only

$$\alpha_{\text{stabi composite}} = 0.030 \text{ mm/mK}$$

$$\alpha_{\text{faser composite}} = 0.035 \text{ mm/mK}$$

and therefore nearly identical with the linear expansion of metal pipes.

The coefficient of linear expansion of fusiotherm®-pipes without stabilizing components is

$$\alpha_{\text{fusiotherm}} = 0.150 \text{ mm/mK}$$

fusiotherm®-stabi / -faser composite pipes must have enough space to expand (see page 59). An expansion control must be required for long and straight stabi composite / faser composite pipes (over 40 m).

fusiotherm®-pipes without the stabilizing compound should have the expansion control after 10 m straight pipelines. Risers of composite pipes may be installed rigidly without expansion compensation. The following formula, calculation examples, data-tables and diagrams help to determine the linear expansion. The difference between working temperature and maximum or minimum installation temperature is essential for the calculation of linear expansion.

Calculation of the linear expansion

Calculation example: Linear expansion

Given and required values

Symbol	Meaning	Value	Measuring unit
ΔL	Linear expansion	?	[mm]
α_1	Coefficient of linear expansion fusiotherm®-stabi composite pipe	0.03	mm/mK
α_2	Coefficient of linear expansion fusiotherm®-faser composite pipe	0.035	mm/mK
α_3	Linear expansion coefficient	0.15	mm/mK
L	Pipe length	25.0	[m]
T_w	Working temperature	60.0	°C
T_M	Installation temperature	20.0	°C
ΔT	Temperature difference between working and installation temperature ($\Delta T = T_w - T_M$)	40.0	K

The linear expansion ΔL is calculated according to the following formula:

$$\Delta L = \alpha \times L \times \Delta T$$

Material:

fusiotherm®-stabi composite pipe ($\alpha = 0.03 \text{ mm/mK}$)

$$\Delta L = 0.03 \text{ mm/mK} \times 25.0 \text{ m} \times 40 \text{ K}$$

$$\Delta L = 30.0 \text{ mm}$$

Linear expansion comparison:

faser composite- to standard PP-pipe

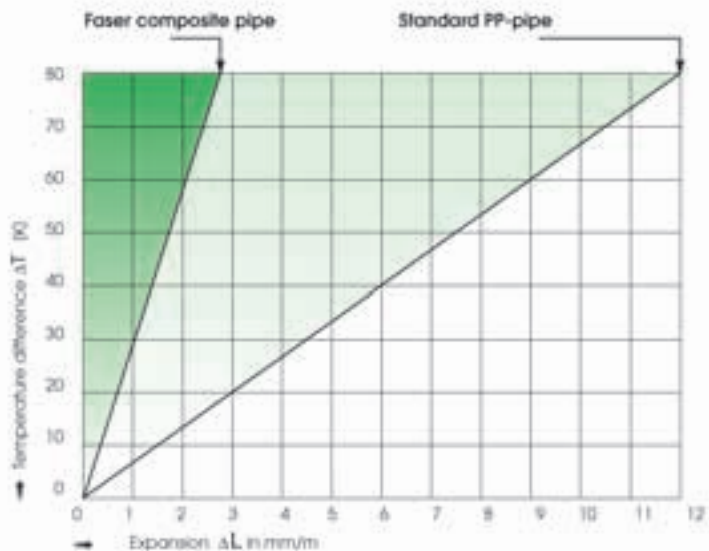

fusiotherm[®]-pipe / climatherm-pipe (without faser)

The linear expansion, described on the preceding pages, can be taken from the following tables and graphs.

Linear expansion ΔL in [mm]: fusiotherm[®]-pipe and climatherm-pipe - $\alpha = 0,150 \text{ mm/mK}$

Pipe length	Difference in temperature $\Delta T = T_{\text{operating temperature}} - T_{\text{installation temperature}}$							
	10 K	20 K	30 K	40 K	50 K	60 K	70 K	80 K
	Linear expansion ΔL (mm)							
5 m	8	15	23	30	38	45	53	60
10 m	15	30	45	60	75	90	105	120
15 m	23	45	68	90	113	135	158	180
20 m	30	60	90	120	150	180	210	240
25 m	38	75	113	150	188	225	263	300
30 m	45	90	135	180	225	270	315	360
35 m	53	105	158	210	263	315	368	420
40 m	60	120	180	240	300	360	420	480
45 m	68	135	203	270	338	405	473	540
50 m	75	150	225	300	375	450	525	600

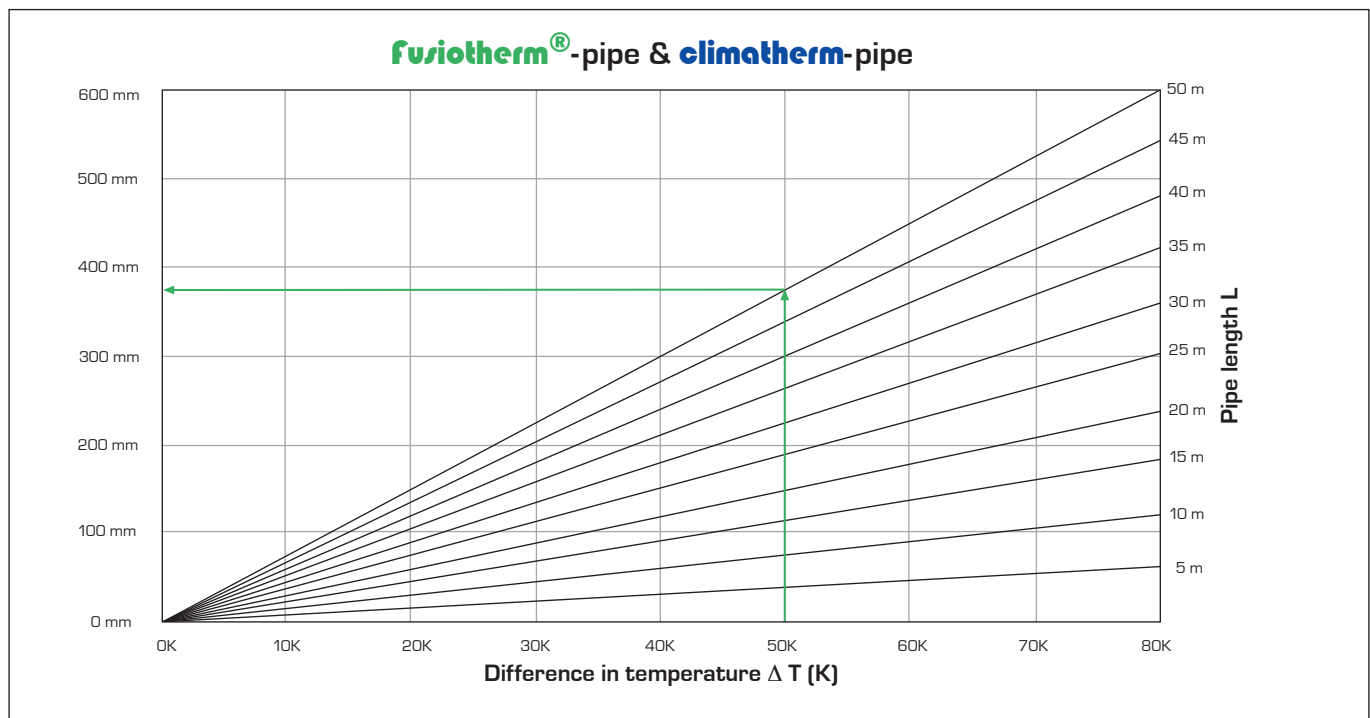

fusiotherm[®]-faser composite pipe climatherm-faser composite pipe

Due to the integration and positive bond of the different materials, the fusiotherm[®]- and climatherm-faser composite pipe offers much higher stability.

The linear expansion reduces its value to $\frac{1}{5}$ of the mere PP-pipes.

Linear expansion ΔL in [mm]: fusiotherm[®]-faser composite pipe and climatherm-faser composite pipe - $\alpha = 0.035 \text{ mm/mK}$

Pipe length	Difference in temperature $\Delta T = T_{\text{operating temperature}} - T_{\text{installation temperature}}$							
	10 K	20 K	30 K	40 K	50 K	60 K	70 K	80 K
	Linear expansion ΔL (mm)							
10 m	4	7	11	14	18	21	25	28
20 m	7	14	21	28	35	42	49	56
30 m	11	21	32	42	53	63	74	84
40 m	14	28	42	56	70	84	98	112
50 m	18	35	53	70	88	105	123	140
60 m	21	42	63	84	105	126	147	168
70 m	25	49	74	98	123	147	172	196
80 m	28	56	84	112	140	168	196	224
90 m	32	63	95	126	158	189	221	252
100 m	35	70	105	140	175	210	245	280

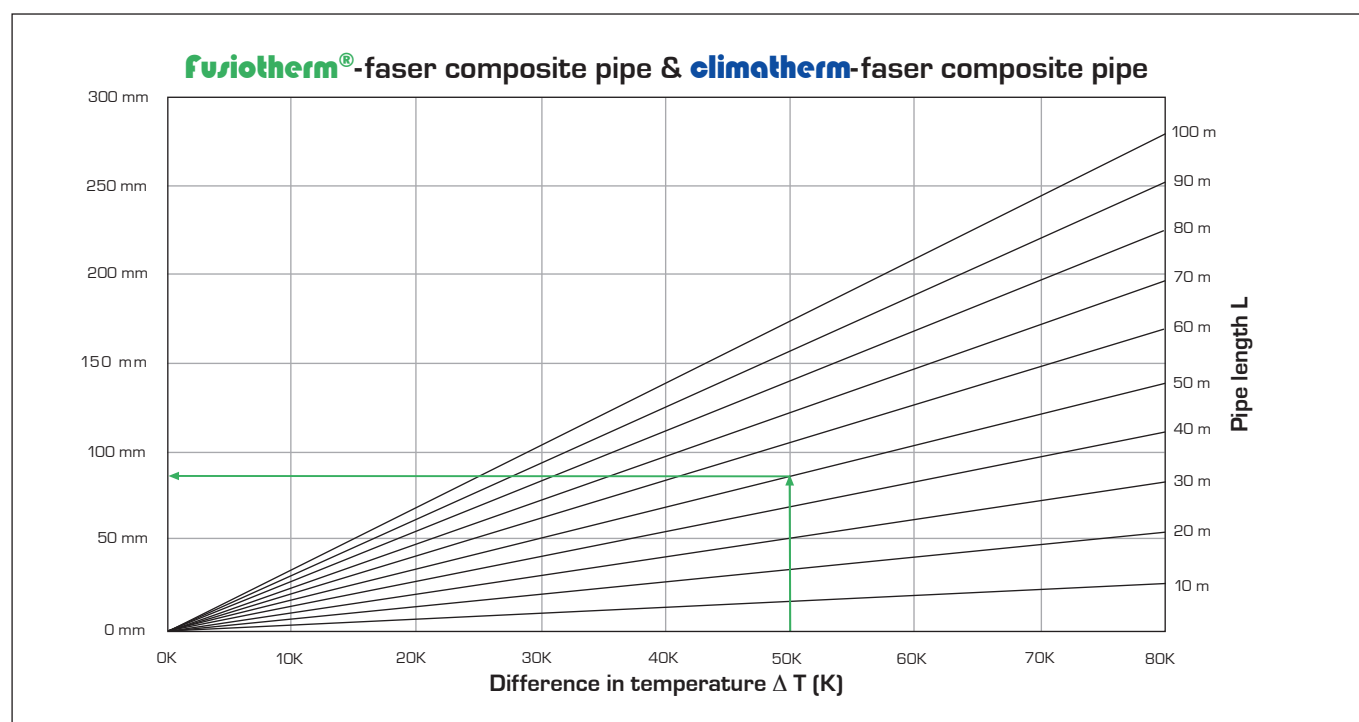

fusiotherm®-stabi composite pipe

Due to the integration and positive bond of the different materials, the fusiotherm®-stabi composite pipe offers much higher stability.

The linear expansion reduces its value to $\frac{1}{5}$ of the mere PP-pipes.

Linear expansion ΔL in [mm]: fusiotherm®-stabi composite pipe - $\alpha = 0,030 \text{ mm/mK}$

Pipe length	Difference in temperature $\Delta T = T_{\text{operating temperature}} - T_{\text{installation temperature}}$							
	10 K	20 K	30 K	40 K	50 K	60 K	70 K	80 K
	Linear expansion ΔL (mm)							
10 m	3	6	9	12	15	18	21	24
20 m	6	12	18	24	30	36	42	48
30 m	9	18	27	36	45	54	63	72
40 m	12	24	36	48	60	72	84	96
50 m	15	30	45	60	75	90	105	120
60 m	18	36	54	72	90	108	126	144
70 m	21	42	63	84	105	126	147	168
80 m	24	48	72	96	120	144	168	192
90 m	27	54	81	108	135	162	189	216
100 m	30	60	90	120	150	180	210	240

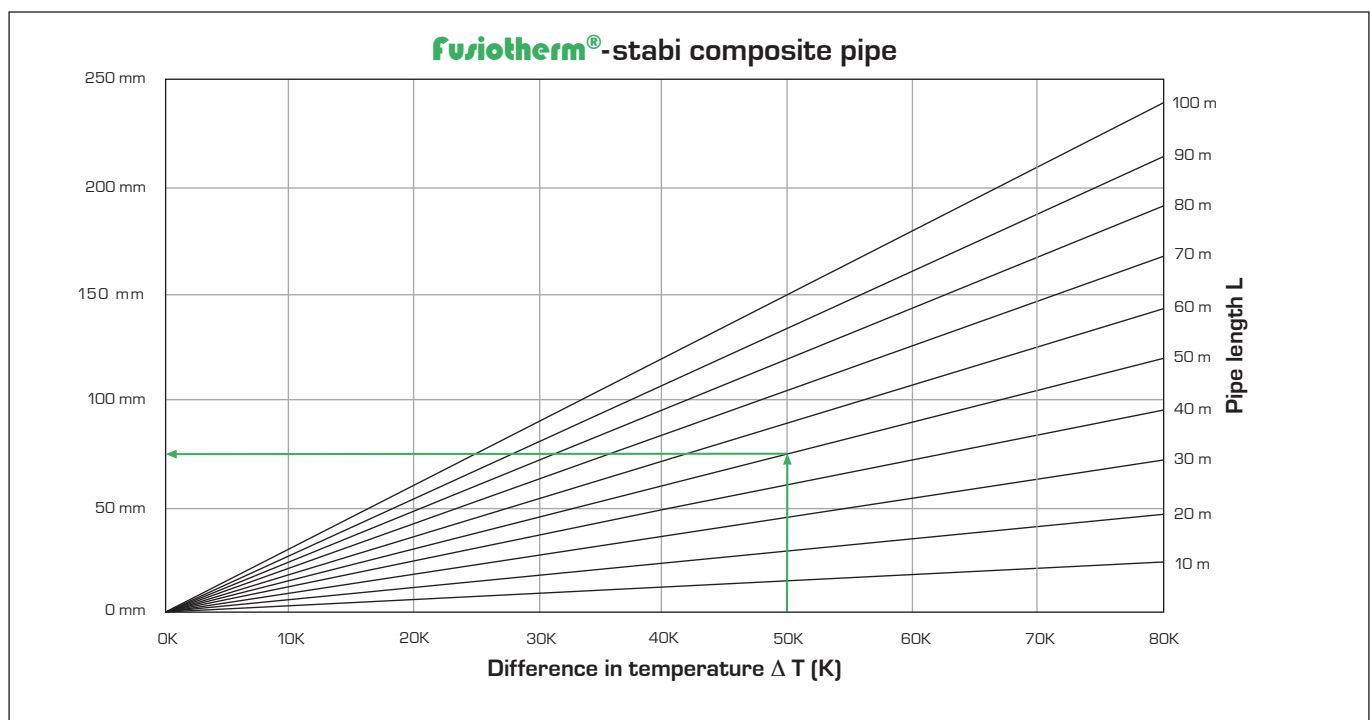

Bending side / Expansion loop

Linear expansion due to temperature difference between operating temperature and installation temperature can be compensated by different installation techniques.

Bending side

In most cases direction changes can be used to compensate for linear expansion in pipes.

The values of the bending side can be taken directly from the tables and graphs on the following pages.

Symbol	Meaning	
L_{BS}	Length of the bending side	[mm]
K	Material specific constant	15.0
d	Outside diameter	[mm]
ΔL	Linear expansion	[mm]
L	Pipe Length	[m]
FP	Fixed point	
SP	Sliding point	

Calculational determination of the bending side length

$$L_{BS} = K \times \sqrt{d \times \Delta L}$$

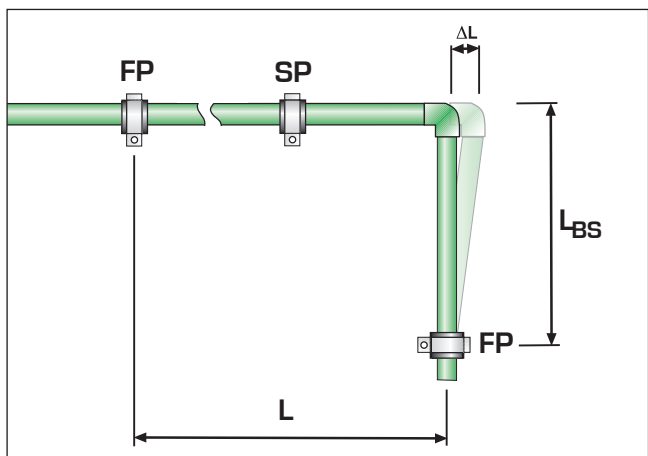

Expansion loop

If the linear expansion cannot be compensated by a change in direction, it will be necessary to install an expansion loop with long and straight pipelines.

In addition to the length of the bending side L_{BS} the width of the pipe bend A_{min} must be considered.

Symbol	Meaning	
A_{min}	Width of the expansion loop	[mm]
SD	Safety distance	150 mm

The pipe bend A_{min} is calculated acc. to the following formula:

$$A_{min} = 2 \times \Delta L + SD$$

The width of the expansion loop A_{min} should be at least 210 mm.

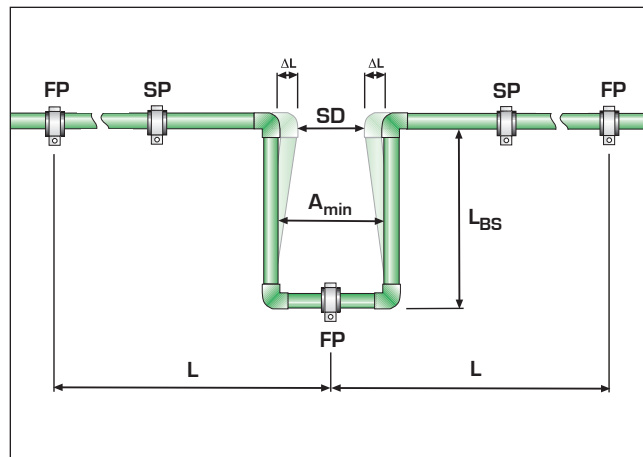

Pre-stress / Bellow expansion joint

Pre-stress

Where space is limited, it is possible to shorten the total width A_{min} as well as the length of the bending side L_{BSV} by pre-stressing.

Pre-stress installations, if planned and carried out carefully, offer an optically perfect installation, as the linear expansion is hardly visible.

The side length L_{SV} is calculated acc. to the following calculation example:

Symbol	Meaning	Value	Measuring unit
L_{BSV}	Length of pre-stress	-	[mm]

The side length of expansion loops with pre-stress is calculated acc. to the following example:

$$L_{BSV} = K \times \sqrt{d \times \frac{\Delta L}{2}}$$

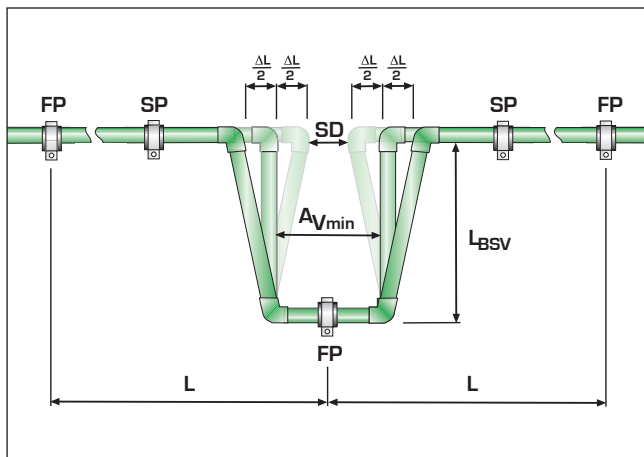

Bellow expansion joint

All bellow expansion joints for corrugated pipes designed for metal materials are unsuitable for fusiotherm®-pipes.

When using axial expansion joints observe the manufacturer's instructions.

Length of bending side

Length of bending side for fusiotherm[®], fusiotherm[®]-faser composite pipe and for fusiotherm[®]-stabi composite pipe, climatherm-pipe and climatherm-faser composite pipe

Pipe Dimension	Linear expansion (mm)											
	10	20	30	40	50	60	70	80	90	100	110	120
	Length of bending side (mm)											
20 mm	0.21	0.30	0.37	0.42	0.47	0.52	0.56	0.60	0.64	0.67	0.70	0.73
25 mm	0.24	0.34	0.41	0.47	0.53	0.58	0.63	0.67	0.71	0.75	0.79	0.82
32 mm	0.27	0.38	0.46	0.54	0.60	0.66	0.71	0.76	0.80	0.85	0.89	0.93
40 mm	0.30	0.42	0.52	0.60	0.67	0.73	0.79	0.85	0.90	0.95	0.99	1.04
50 mm	0.34	0.47	0.58	0.67	0.75	0.82	0.89	0.95	1.01	1.06	1.11	1.16
63 mm	0.38	0.53	0.65	0.75	0.84	0.92	1.00	1.06	1.13	1.19	1.25	1.30
75 mm	0.41	0.58	0.71	0.82	0.92	1.01	1.09	1.16	1.23	1.30	1.36	1.42
90 mm	0.45	0.64	0.78	0.90	1.01	1.10	1.19	1.27	1.35	1.42	1.49	1.56
110 mm	0.50	0.70	0.86	0.99	1.11	1.22	1.32	1.41	1.49	1.57	1.65	1.72
125 mm	0.53	0.75	0.92	1.06	1.19	1.30	1.40	1.50	1.59	1.68	1.76	1.84
160 mm	0.60	0.85	1.04	1.20	1.34	1.47	1.59	1.70	1.80	1.90	1.99	2.08
200 mm	0.67	0.95	1.16	1.34	1.50	1.64	1.77	1.90	2.01	2.12	2.22	2.32
250 mm	0.75	1.06	1.30	1.50	1.68	1.84	1.98	2.12	2.25	2.37	2.49	2.60

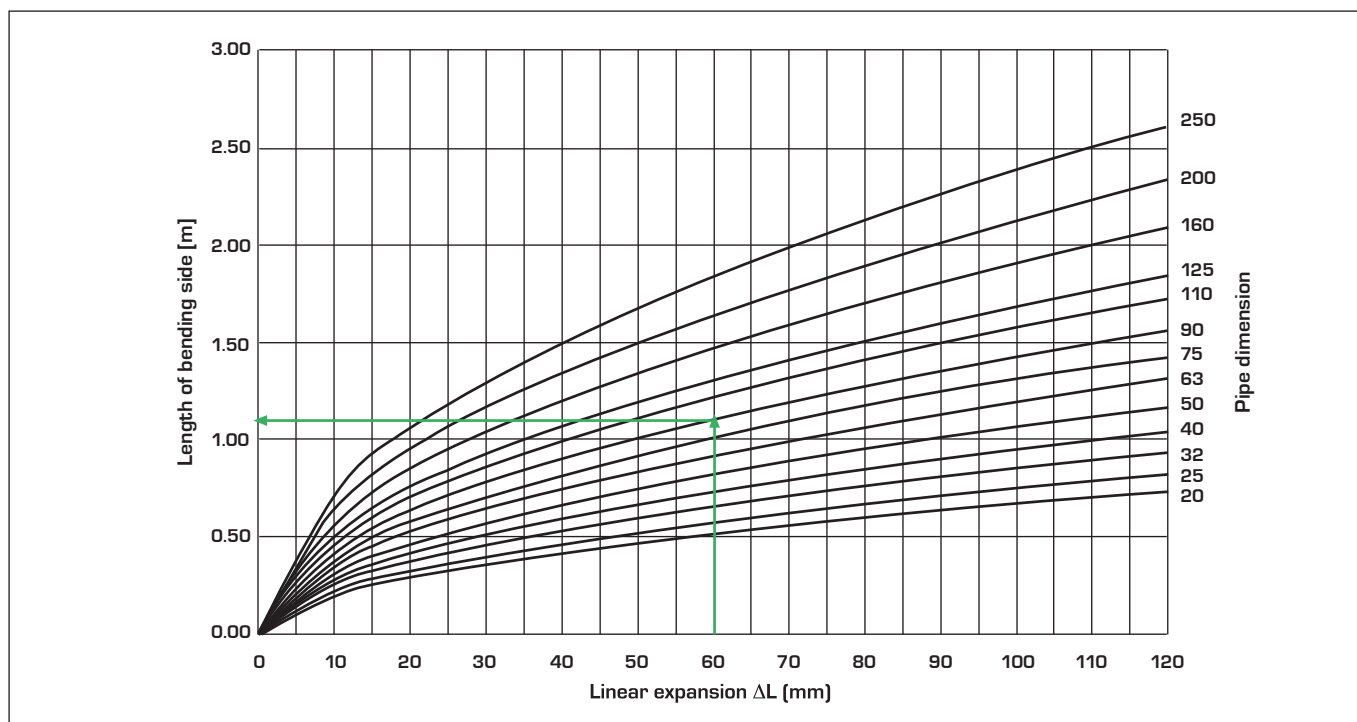

The length of the bending side L_{BS} can be taken from the tables and graphs in consideration of the applied pipe dimensions and determined linear expansion.

Length of bending side with pre-stress

Length of bending side with pre-stress for fusiotherm®, fusiotherm®-faser composite pipe and for fusiotherm®-stabi composite pipe, climatherm-pipe and climatherm-faser composite pipe

Pipe Dimension	Linear expansion [mm]											
	10	20	30	40	50	60	70	80	90	100	110	120
	Length of bending side with pre-stress (mm)											
20 mm	0.15	0.21	0.26	0.30	0.34	0.37	0.40	0.42	0.45	0.47	0.50	0.52
25 mm	0.17	0.24	0.29	0.34	0.38	0.41	0.44	0.47	0.50	0.53	0.56	0.58
32 mm	0.19	0.27	0.33	0.38	0.42	0.46	0.50	0.54	0.57	0.60	0.63	0.66
40 mm	0.21	0.30	0.37	0.42	0.47	0.52	0.56	0.60	0.64	0.67	0.70	0.73
50 mm	0.24	0.34	0.41	0.47	0.53	0.58	0.63	0.67	0.71	0.75	0.79	0.82
63 mm	0.27	0.38	0.46	0.53	0.60	0.65	0.70	0.75	0.80	0.84	0.88	0.92
75 mm	0.29	0.41	0.50	0.58	0.65	0.71	0.77	0.82	0.87	0.92	0.96	1.01
90 mm	0.32	0.45	0.55	0.64	0.71	0.78	0.84	0.90	0.95	1.01	1.06	1.10
110 mm	0.35	0.50	0.61	0.70	0.79	0.86	0.93	0.99	1.06	1.11	1.17	1.22
125 mm	0.38	0.53	0.65	0.75	0.84	0.92	0.99	1.06	1.13	1.19	1.24	1.30
160 mm	0.42	0.60	0.73	0.85	0.95	1.04	1.12	1.20	1.27	1.34	1.41	1.47
200 mm	0.47	0.67	0.82	0.95	1.06	1.16	1.25	1.34	1.42	1.50	1.57	1.64
250 mm	0.53	0.75	0.92	1.06	1.19	1.30	1.40	1.50	1.59	1.68	1.76	1.84

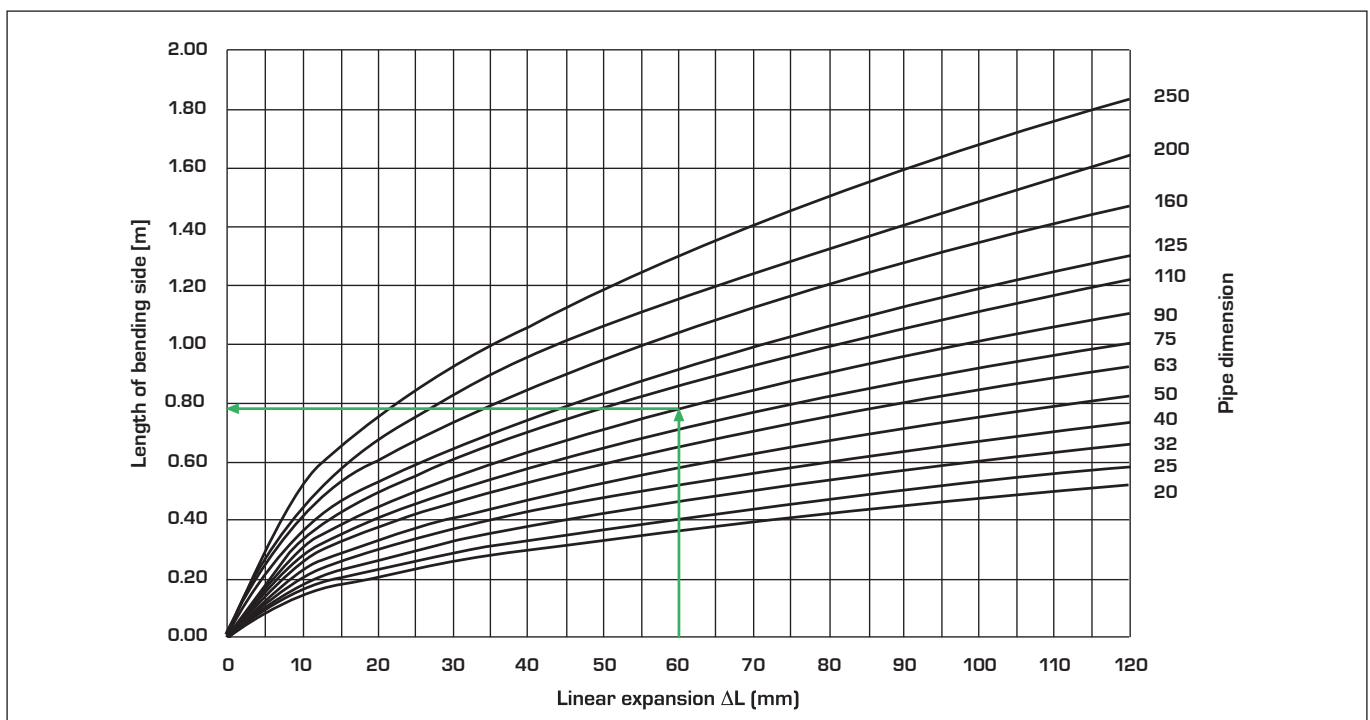

The length of the bending side with pre-stress L_{BSV} can be taken from the tables and graphs in consideration of the applied pipe dimensions and determined linear expansion.

Support intervals

Support intervals

fusiotherm[®]-pipe SDR 6 & SDR 7.4

Table to determine support intervals in conjunction with temperature and outside diameter.

Difference in tem- perature ΔT [K]	Pipe diameter d (mm)									
	16	20	25	32	40	50	63	75	90	110
	Support intervals in cm									
0	70	85	105	125	140	165	190	205	220	250
20	50	60	75	90	100	120	140	150	160	180
30	50	60	75	90	100	120	140	150	160	180
40	50	60	70	80	90	110	130	140	150	170
50	50	60	70	80	90	110	130	140	150	170
60	50	55	65	75	85	100	115	125	140	160
70	50	50	60	75	80	95	105	115	125	140

Support intervals

fusiotherm[®]-pipe SDR 11 & **climatherm**-pipe SDR 11

Table to determine support intervals for cold water application (temperature of medium: 20° C) in conjunction with outside diameter.

Pipe diameter d (mm)												
20	25	32	40	50	63	75	90	110	125	160	200	250
Support intervals in cm												
60	75	90	100	120	140	150	160	180	200	220	230	240

Support intervals

Support intervals

fusiotherm[®]-stabi composite pipe

Table to determine support intervals in conjunction with temperature and outside diameter.

Difference in temperature ΔT [K]	Pipe diameter d (mm)									
	16	20	25	32	40	50	63	75	90	110
	Support intervals in cm									
0	130	155	170	195	220	245	270	285	300	325
20	100	120	130	150	170	190	210	220	230	250
30	100	120	130	150	170	190	210	220	230	240
40	100	110	120	140	160	180	200	210	220	230
50	100	110	120	140	160	180	200	210	220	210
60	80	100	110	130	150	170	190	200	210	200
70	70	90	100	120	140	160	180	190	200	200

Support intervals

fusiotherm[®]-faser composite pipe SDR 7.4 &

climatherm-faser composite pipe SDR 11

Table to determine support intervals in conjunction with temperature and outside diameter.

Difference in temperature ΔT [K]	Pipe diameter d (mm)												
	20	25	32	40	50	63	75	90	110	125	160	200	250
	Support intervals in cm												
0	120	140	160	180	205	230	245	260	290	320	340	345	350
20	90	105	120	135	155	175	185	195	215	240	270	275	280
30	90	105	120	135	155	175	185	195	210	225	245	250	255
40	85	95	110	125	145	165	175	185	200	215	235	240	245
50	85	95	110	125	145	165	175	185	190	195	205	210	215
60	80	90	105	120	135	155	165	175	180	185	195	200	205
70	70	80	95	110	130	145	155	165	170	175	185	190	195

Pipe clamp distances of vertically installed pipes can be increased by 20 % of the tabular values, e.g. to multiply the tabular value by 1.2.

Thermal insulation of hot water pipes

The decree for energy saving thermal protection and energy saving technique for buildings

Decree for Energy Saving (EnEV)

regulates the thermal insulation of hot water supplies and fittings in Germany.

EnEV 2007, § 14, addendum 5, chart 1

Line	Type of pipe/ fitting	minimum thickness of insulation referred to thermal conductivity of 0.035 W / (mK)
1	inner diameter up to 22 mm	20 mm
2	inner diameter more than 22 mm up to 35 mm	30 mm
3	inner diameter more than 35 mm up to 100 mm	same as inner diameter
4	inner diameter more than 100 mm	100 mm
5	pipes and fittings after line 1-4 in wall- and ceiling openings, in crossing area of pipes, at pipe connections, at distributors	$\frac{1}{2}$ of the requirements of line 1 to 4
6	pipes of central heating after line 1-4, which have been installed after introduction of this decree between heated rooms of various users	$\frac{1}{2}$ of the requirements of line 1 to 4
7	pipes after line 6 in floor construction	6 mm

Central heating pipes, line 1-4 installed in heated rooms or building parts between heated rooms of the one user, where heat output can be controlled by open stop valves do not require a minimum thickness of the insulation.

This even applies to hot water pipes up to an inner diameter of 22 mm in flats, which are neither in the circulation nor have an additional electric heating.

Applying material with thermal conductivities different to 0.035 W / (mK) the minimum thickness of the insulation has to be converted correspondingly.

For the conversion and the thermal conductivity of the insulation the ways and values of calculation described in the technical regulations must be applied.

The minimum insulation acc. to the table for heating distributions and heating pipes can be reduced as far as the same limit of heat output even for further insulation requirements in consideration of the insulating effect of the pipe walls are guaranteed.

Insulation thickness acc. to Decree for Energy Saving

Acc. to this decree fusiotherm®-pipes and fittings have to be insulated against loss of heat. The insulation thickness depends on the respective installation.

The heat conductivity figure of fusiotherm® PP-R is 0.15 W/(mK) fusiotherm®-pipes and fittings offer a signifi-

cantly higher degree of insulation compared to metal pipes.

Due to the high insulation values of the fusiotherm®-material PP-R the insulation thickness - compared to metallic pipe systems - can be reduced acc. to the following minimum insulation thickness.

Insulation thickness* acc. to Decree for Energy Saving for fusiotherm®- pipe SDR 6

Thermal conductivity	0.030 W/(mK)		0.035 W/(mK)		0.040 W/(mK)	
	Minimum insulation thickness in mm					
Dimension	50 %	100 %	50 %	100 %	50 %	100 %
16 mm	6.1	12.8	8.0	17.0	10.1	22.2
20 mm	6.1	12.9	7.8	16.8	9.7	21.6
25 mm	6.0	13.0	7.6	16.7	9.3	21.0
32 mm	9.4	19.9	11.8	25.5	14.4	32.2
40 mm	9.3	19.8	11.5	25.1	13.9	31.2
50 mm	9.0	19.7	11.0	24.7	13.2	30.2
63 mm	13.1	27.9	15.9	35.0	19.0	42.9
75 mm	15.6	33.4	19.0	41.7	22.6	51.1
90 mm	18.8	40.2	22.8	50.1	27.1	61.3
110 mm	23.1	49.1	27.9	61.1	33.1	74.7

Insulation thickness* acc. to Decree for Energy Saving for fusiotherm®-stabi-/faser-composite pipe SDR 7.4

Thermal conductivity	0.030 W/(mK)		0.035 W/(mK)		0.040 W/(mK)	
	Minimum insulation thickness in mm					
Dimension	50 %	100 %	50 %	100 %	50 %	100 %
16 mm	6.4	13.0	8.3	17.6	10.7	23.0
20 mm	6.4	13.3	8.2	17.5	10.3	22.5
25 mm	6.4	13.4	8.0	17.3	9.9	21.8
32 mm	9.9	20.5	12.5	26.4	15.3	33.4
40 mm	9.9	20.5	12.2	26.1	14.8	32.5
50 mm	13.3	27.5	16.5	34.9	19.9	43.5
63 mm	15.0	31.1	18.3	39.1	22.0	48.3
75 mm	18.4	38.0	22.5	47.8	27.0	58.9
90 mm	21.7	45.1	26.6	56.6	31.8	69.6
110 mm	27.0	55.7	32.9	69.8	39.2	85.8
** 125 mm	30.8	63.6	37.3	79.0	44.6	97.3
** 160 mm	33.4	69.9	40.4	86.3	47.9	105.5
** 200 mm	35.7	73.8	43.0	90.9	50.7	109.9
** 250 mm	36.0	73.4	41.8	89.8	49.0	107.4

* The insulation thickness has to be calculated due to the thermal conductivity of polypropylene pipes acc. to test report no.: G.2 - 136/97 of FIW-Munich

** only for faser-composite pipe

Insulation thickness acc. to Decree for Energy Saving

Insulation thickness* acc. to Decree for Energy Saving for
climatherm-faser-composite pipe SDR 7.4 & SDR 11

Thermal conductivity	0.030 W/(mK)		0.035 W/(mK)		0.040 W/(mK)	
Dimension	Minimum insulation thickness in mm					
	50 %	100 %	50 %	100 %	50 %	100 %
20 mm	7.0	14.0	8.9	18.2	11.2	23.6
25 mm	7.0	14.2	8.9	18.3	10.9	23.1
32 mm	10.7	21.6	13.4	27.6	16.4	35.2
40 mm	10.7	21.6	13.2	27.3	16.1	34.2
50 mm	14.7	29.4	18.2	37.7	22.1	47.1
63 mm	18.4	36.9	22.7	46.5	27.4	58.3
75 mm	22.1	44.3	27.2	56.1	32.8	69.7
90 mm	26.9	63.7	33.0	68.0	39.8	84.4
110 mm	32.7	66.9	40.1	83.3	48.2	103.3
** 125 mm	36.5	73.2	44.7	92.4	53.6	114.4
** 160 mm	36.2	73.5	43.9	91.5	52.2	111.7
** 200 mm	36.7	73.8	43.0	90.9	50.7	109.9
** 250 mm	36.0	73.4	41.8	89.8	49.0	107.4

* The insulation thickness has to be calculated due to the thermal conductivity of polypropylene pipes acc. to test report no.: G.2 - 136/97 of FIW-Munich

** only for faser-composite pipe

Thermal insulation of cold water pipes

As stipulated in

➔ **DIN 1988, Part 2**

potable water plants (cold) have to be protected against heating-up and condensation. Standard values for the minimum insulation thicknesses have to be taken from the following table. The given insulation thicknesses are applicable to all pipe materials and also to fusiotherm®-pipes.

The values correspond to the German Industry Standard (DIN) and have to be adapted to the respective national regulations.

Standard values for the minimum insulation thicknesses for the insulation of potable water plants (cold)	
Type of the installation	Insulation thickness at $\lambda = 0,040$ W/(mK)*
Open installed pipe, in a not heated room (i. e. basement)	4 mm
Open installed pipe, in a heated room	9 mm
Pipe in a duct, without hot water pipes	4 mm
Pipe in a duct, beside hot water pipes	13 mm
Pipe in a pipe chase riser	4 mm
Pipe in a pipe chase, beside hot water pipes	13 mm
Pipe on a concrete floor	4 mm

*The insulation thicknesses, applied to a diameter of $d = 20$ mm, for other coefficients of thermal conduction have to be calculated correspondingly.

Pressure test / Test control / Measuring of the test pressures / Test record

Pressure test / Test control

Acc. to the

► **Technical Rules for Potable Water Installations DIN 1988**

have to be (while still visible) hydraulically pressure tested all pipelines. The test pressure has to be 1.5 times of the operating pressure.

Due to the material properties of fusiotherm®-pipes a pressurization causes an expansion of the pipe. Different temperatures of pipe and test medium lead to alterations of pressure. A temperature change of 10 K corresponds to a pressure difference of 0.5 to 1 bar.

The pressure test of fusiotherm®-pipe systems should be made with a constant temperature of the medium.

The hydraulic pressure test requires a preliminary, principal and final test.

In the preliminary test the system is pressurized with the 1.5 times of the maximum operating pressure.

This test pressure has to be re-established twice within 30 minutes within an interval of 10 minutes. After a test time of a further 30 minutes the test pressure must not drop more than 0.6 bar. No leakage may appear.

The preliminary test is to be followed directly by the principal test. Test time is 2 hours. Now the test pressure taken from the preliminary test may not fall more than 0.2 bar.

Upon completion of the preliminary and principal tests the final test must be conducted. In the final test the system is pressurized in a frequency of 5 minutes with a changing test pressure of 10 and 1 bar.

Between each test course the pressure has to be released.

No leakage must appear at any point of the tested installation system.

Measuring of the test pressures

Measuring has to be done with a manometer allowing a perfect reading of a pressure change of 0.1 bar. The manometer has to be placed at the deepest point of the installation.

Test record

A record of the hydraulic pressure test has to be prepared and signed by the client and contractor stating place and date (see page: 73).

Pressure test / Test control

Preliminary- and principal test

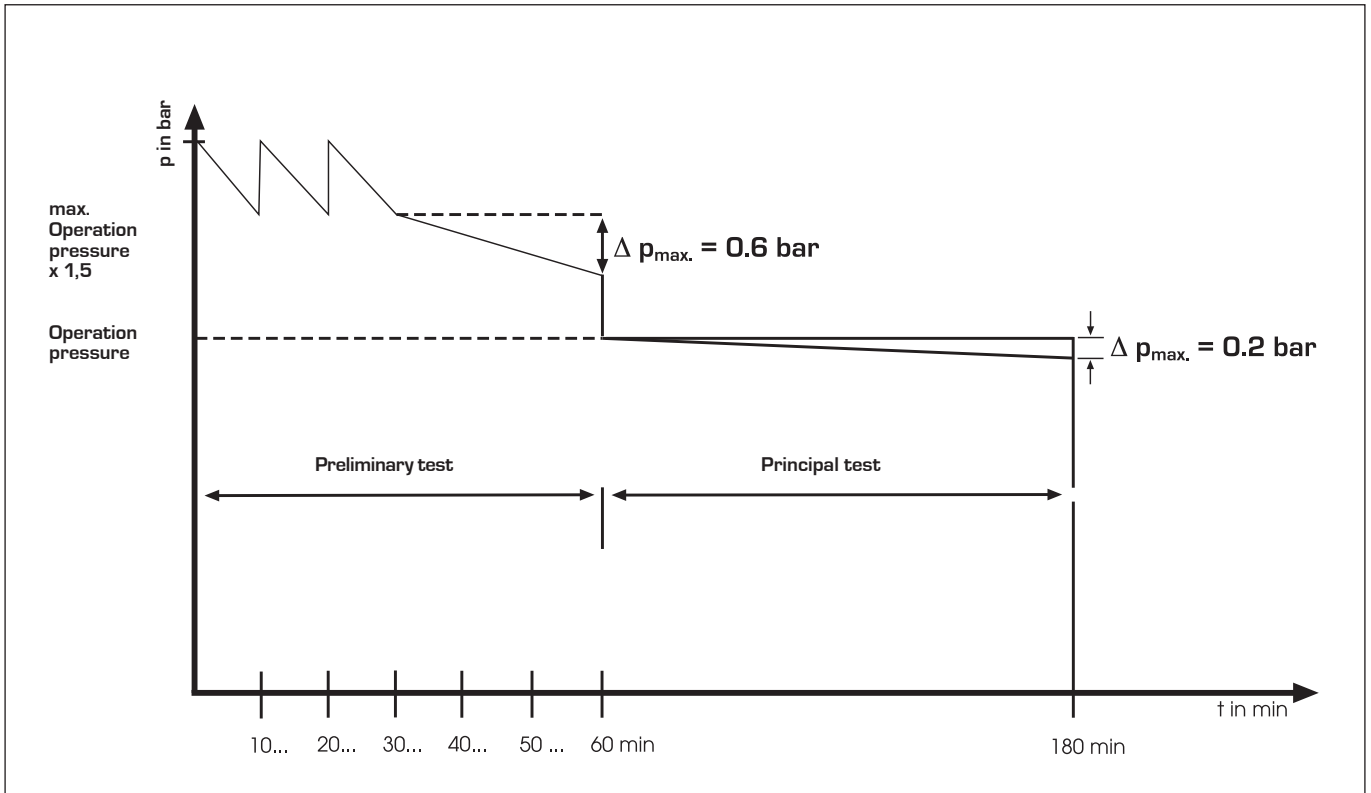

Final test

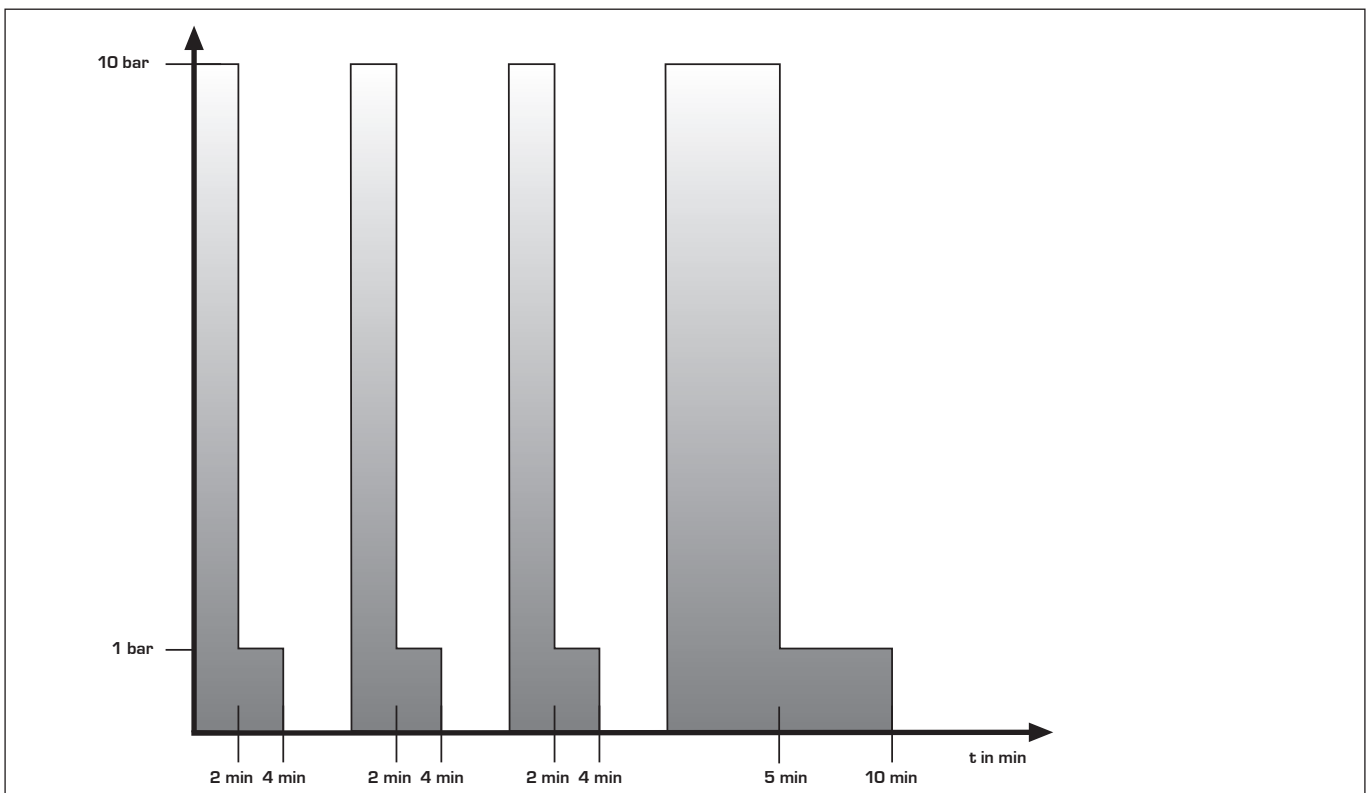

Test record - fusiotherm[®]-pipe installation

Description of the installation

Place: _____

Object: _____

Pipe-lengths: Ø 16 mm _____ m
 Ø 20 mm _____ m
 Ø 25 mm _____ m
 Ø 32 mm _____ m
 Ø 40 mm _____ m
 Ø 50 mm _____ m
 Ø 63 mm _____ m
 Ø 75 mm _____ m
 Ø 90 mm _____ m
 Ø 110 mm _____ m
 Ø 125 mm _____ m
 Ø 160 mm _____ m
 Ø 200 mm _____ m
 Ø 250 mm _____ m

Highest point: _____ m
 (over manometer)

Start of the test: _____

End of the test: _____

Test period: _____

Client: _____

Contractor: _____

Place: _____

Date: _____

Stamp / Signature

Preliminary test

max. working pressure x 1.5 _____ bar

Pressure drop after 30 minutes: _____ bar
 (max. 0.6 bar)

Result preliminary test: _____

Principal test

Working pressure: _____ bar
 (Result preliminary test)

Pressure after 2 hour: _____ bar
 (max. 0.2 bar)

Result principal test: _____

Final test*

1. Working pressure 10 bar: _____ bar
 at least 2 minutes, then
 Working pressure 1 bar: _____ bar
 at least 2 minutes
2. Working pressure 10 bar: _____ bar
 at least 2 minutes, then
 Working pressure 1 bar: _____ bar
 at least 2 minutes
3. Working pressure 10 bar: _____ bar
 at least 2 minutes, then
 Working pressure 1 bar: _____ bar
 at least 2 minutes
4. Working pressure 10 bar: _____ bar
 at least 5 minutes, then
 Working pressure 1 bar: _____ bar
 at least 5 minutes

* Unpressurize the pipe between each cycle.

Flushing of pipes / Earth wire / Transport and storage

Flushing of pipes

The technical rule for potable water installations (TRWI)

➔ DIN 1988, Part 2

includes a paragraph about the flushing of pipes, which has to be carried out with an air-water-mixture under pressure.

Basically all potable water plants, independent of their material, have to be flushed thoroughly after their installation. The following requirements have to be complied with before the installation can be put into service:

- ➔ protection of the potable water quality
- ➔ avoidance of corrosion damage
- ➔ avoidance of malfunctions of armatures and apparatus.
- ➔ cleanliness of the inner surface of the pipe

These requirements are met by

- ➔ **flushing with water**
- ➔ flushing with air-water-mixture

On choosing the type of flushing required, the experiences of the installer, the requirements of the client and the instructions of the system manufacturer have to be observed.

For potable water installations acc. to DIN 1988, the fusiotherm®-pipe system complies with, “**1 - flushing with water**” is sufficient..

The fusiotherm®-pipe system complies with DIN 1988 for potable water installations. Thus, flushing with water is sufficient, acc. to procedure 1 stipulated therein.

For this reason it is sufficient to flush the installation with water only.

Earth wire

DIN VDE 0100, Part 701 contains safety measures for rooms containing baths or showers. Among other aspects, this standard regulates the potential balance for such rooms.

The standard stipulates that all conductive components such as metal baths and shower trays, metal outlet valves, metal stench traps and metal pipe systems (e. g. drinking water and heating pipe systems) must be connected to each other.

The connection to an earth conductor must be provided, at a central point, e.g. in the building`s mini-distributors installation (power circuit distributors).

Information on renovating potable drinking water pipe systems using fusiotherm®-pipes:

Where metal pipes are replaced by fusiotherm®- pipes, the potential balance can not be created by the water pipes.

It should be ensured that the potential balance is checked out by a qualified electrician.

Transport and storage

fusiotherm®-pipes may be stored outside at any temperature. A solid base for the pipe is very important to avoid a deformation of the pipes while in transport and storage.

At temperatures below 0 °C it is possible to damage the pipes through strong impacts. The material has to be treated with caution at low temperatures.

In spite of its high resistance fusiotherm®-pipes should be treated with care.

UV-radiation has effects on all high polymer plastics. Do not store permanently outdoor. Maximum storage time (outdoor) is 6 months.

Water point connections

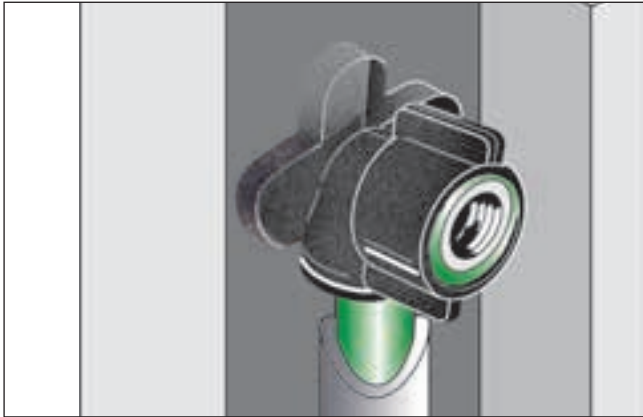

fusiotherm®-back plate elbow in sound insulation cover (Art.-No. 20120), e.g. in a pipe chase or for concealed installation

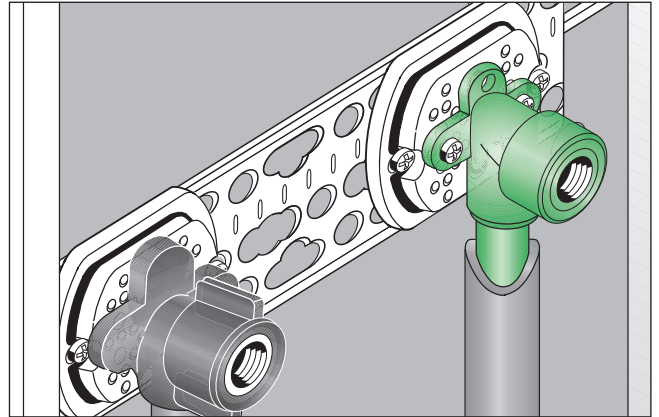

fusiotherm®-back plate elbow for twin water point connections with galvanized mounting plate and sound insulation plate (Art.-No. 79080) from the fixing program (gauge for bore holes 220-153-80 mm)

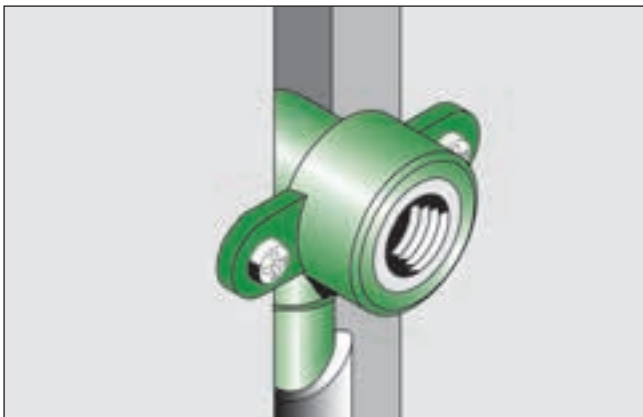

fusiotherm®-back plate elbow for dry construction installed in a pipe chase

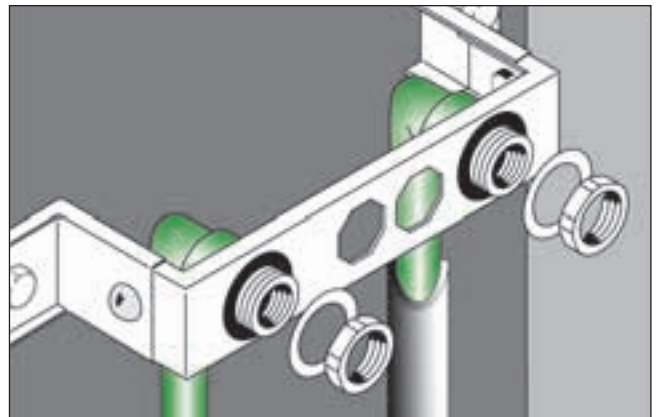

Mounting unit twin (gauge for bore holes 80 - 100 - 150 mm) incl. 2 fusiotherm®-transition elbows female/ male with counternut, gasket and spring washer

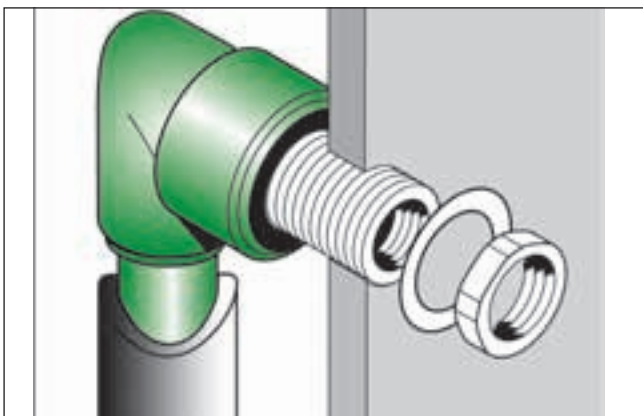

fusiotherm®-transition elbow female/ male for dry construction with 30 mm thread

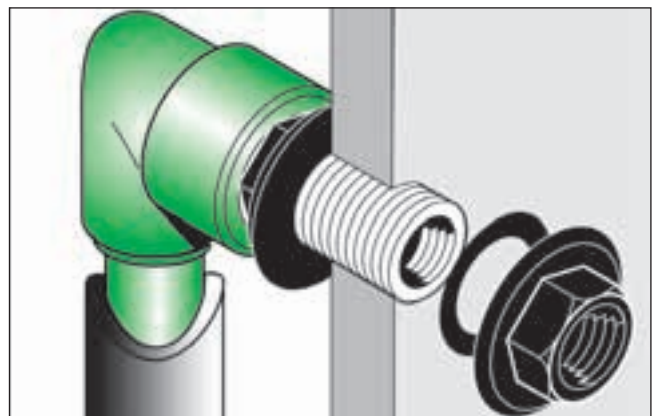

fusiotherm®-dry construction wall fitting with fusiotherm®-transition elbow

The fusiotherm®- transition elbow with female/ male thread is suitable for flushing box connections. This transition elbow is also available with a single mounting unit.

Distribution block: Example of applications

Distribution block: Example of applications

The stamped numbers 1 and 2 indicate the proper connection of the fusiotherm®-distribution block. They provide assistance with the installation.

In case of the "heating" connection variant (top A), the return is connected to the supply channel marked 1 and the flow to supply channel marked 2. The connections can also be used reverse.

In potable water connection variant (top B), supply channel 1 is intended for the cold water pipe and supply channel 2 for the hot water pipe connection. In as-delivered condition, the lower outlets are closed. The connection with supply channel 2 is made by drilling out (18 mm drill bit). Thus an additional pipe can be connected.

By turning the fusiotherm®-distribution block a mirror-image connection can be made. These variants are presented in the illustrations C and D.

The flow and return connections of the aquatherm®-distribution block heating are installed with Ø 20 mm pipes. For radiator connections Ø 16 mm pipes have to be welded into the outflow sockets of the distribution block.

The fusiotherm®-distribution block plumbing has to be connected with Ø 25 mm pipes. For pipe connections to the taps, Ø 20 mm pipes have to be welded into the outflow sockets of the distribution block.

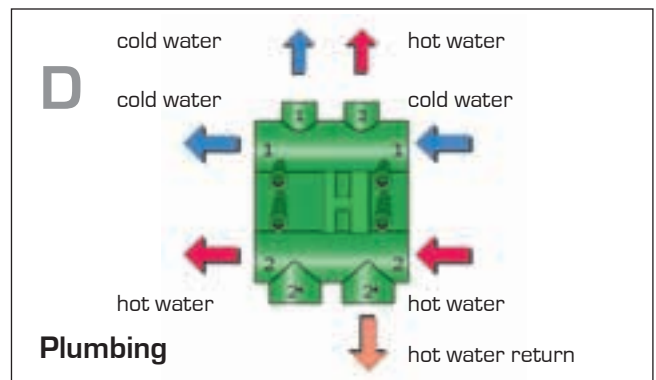
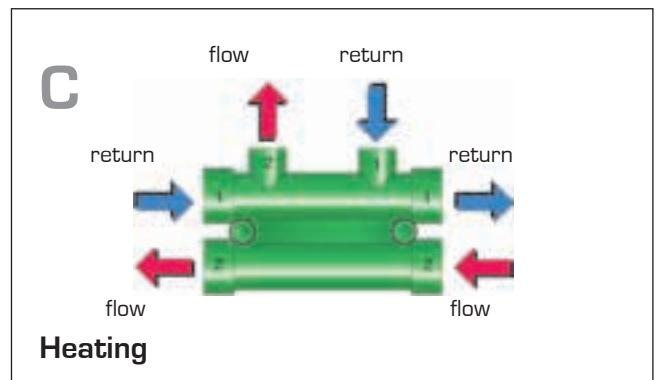
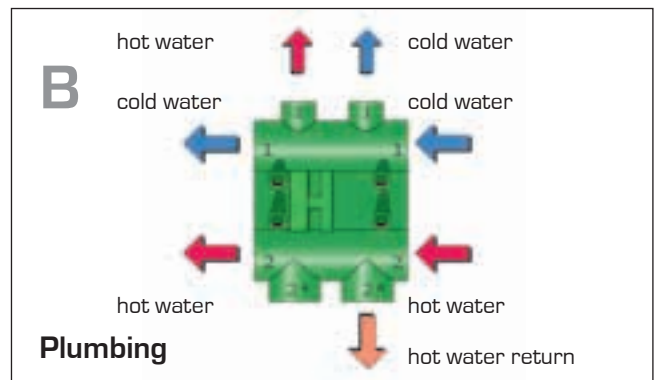
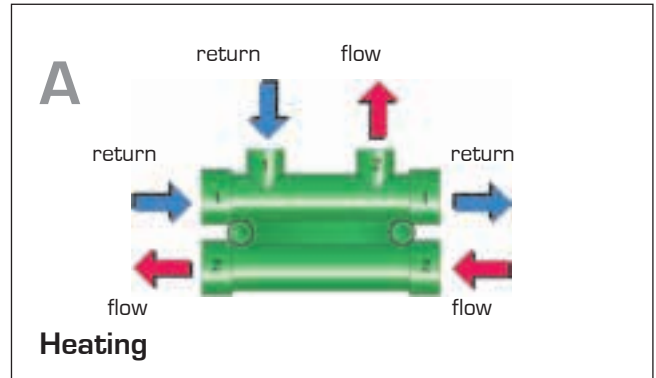

fusiotherm[®]-distribution block: Example of applications - potable water



The connection pipes in the individual floors or risers are connected for hot and cold water with fusiotherm[®]- or fusiotherm[®]-composite pipes with an external diameter of 25 mm. The same applies for also for the hot water return which can be led back from any fusiotherm[®]-distribution block.



Reducers for further pipe systems can be welded directly onto the distribution block.



The supplied 25 mm end plug seals off a through-flow unit or, alternatively, the 16 mm end cap. By cutting the end of the plug, it can be used as 25 mm to 16 mm reducer or as 16 mm socket.

By turning the fusiotherm[®]-distribution block and drilling out the factory-sealed outlets, it is possible to create compact connection arrangements even in areas of restricted space.

This avoids the time-consuming operation of guiding under or over pipes and the associated sealing work.

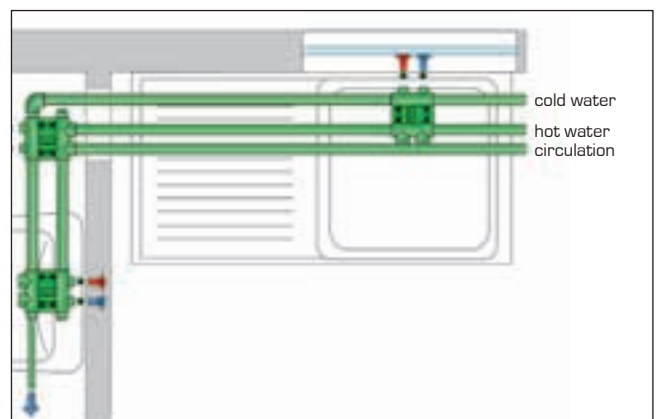

Insulation for distribution block / **aquatherm**[®]-distribution block

Insulation for distribution block

It is also possible to install the compact distribution block by using a specially adapted insulation. In this case the green junction does not only avoid the crossing of pipes, but also the extra work involved in the expensive insulation of the double tee-branch.

The insulation for the fusiotherm[®]-distribution block is made from high-quality PPO/PS rigid expanded polyurethane. Thus, a fast, unproblematic and safe insulation acc. to the current Decree for the Installation of Heating Systems is provided.

- Thermal conductivity : WLG 040
- Length : 184 mm
- Width : 119 mm
- Height : 70 mm

The accessories (1 plug, 2 fastening plugs) are integrated in the insulation of supply unit fusiotherm[®]-distribution block with insulation block (Art.-No. 30130, see picture).

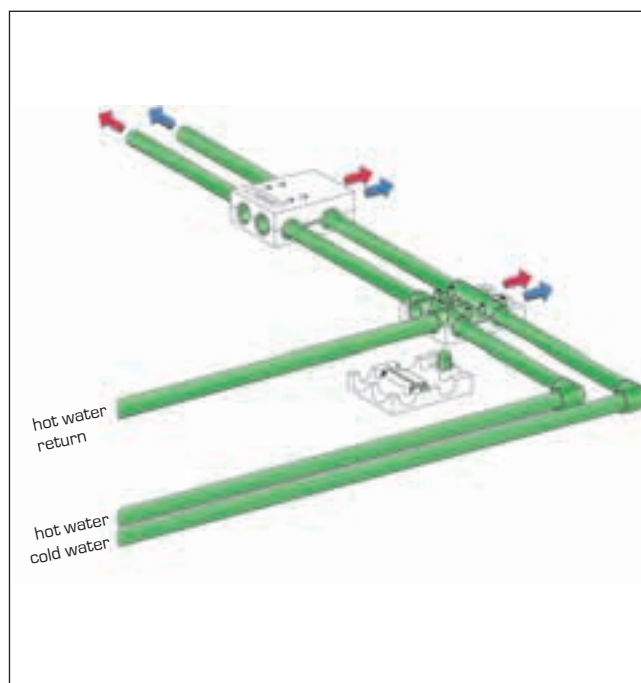

Insulation block for distribution block

aquatherm[®]-distribution block

If the radiator connection is not in the immediate vicinity of the pipe connection of the distribution block, this supply can be arranged with a 16 mm pipe by welding-in of two reducers 20/ 16 mm (Art.-No. 11109).

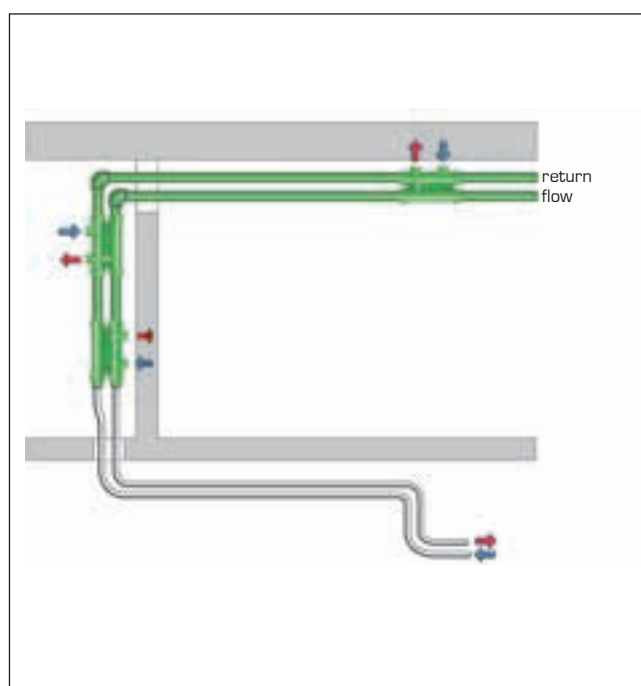

distribution block

aquatherm[®]-distribution block: Example of applications - heating



The flow and return connections of heating pipes to the aquatherm[®]-distribution block are with fusiotherm[®]- or fusiotherm[®]-composite pipes of an external diameter of 20 mm. Used in conjunction with the aquatherm[®]-connecting bend (Art.-No. 85120) and the aquatherm[®]-radiator valves (Art.-No. 85102 or 85106), the outgoing 16 mm pipe connections are ideal for radiator connections.

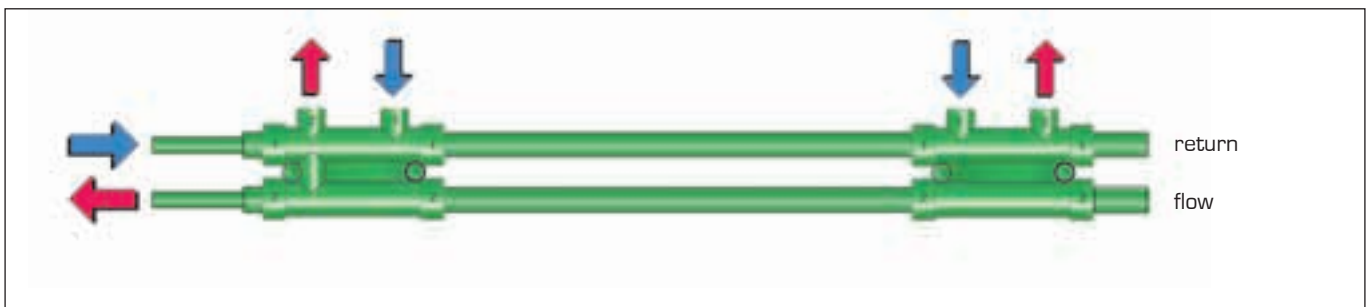

It is of no importance, where the heating flow or return is connected to the aquatherm[®]-distribution block. A simply turning of the distribution block adapts it to the appropriate specification.

Chapter 5

Planning

DIN 1988 T3 / Maximum flow rate / Principles of calculation / Calculation guide / Software

DIN 1988 T3

Part 3 of the DIN 1988 (Technical Rules for Potable Water Installations) specifies the calculation principles for the determining of the pipe diameter.

The determining of the pipe diameter is based on the calculation of the pressure loss in pipes.

Beside the diameter the pressure loss depends on the length of the pipe, the pipe material and on the flow rate, dependent on the quantity and size of the water points to which the pipe is connected.

The basis for determining the maximum flow rate should be calculated on the desired flow rate of each water point. The simultaneous use resp. the peak pressure of flow of an installation part has to be determined by taking the calculation values from DIN 1988 T 3 as a basis.

Maximum flow rate

A further criterion for the selection of the pipe diameter is the maximum permissible flow rate. Because of sonic reasons and for the limitation of water hammer, the calculated flow rate may not exceed the values of the table below.

Section of the installation	max. calculated flow rate at run	
	≤ 15 min. m/s	> 15 min. m/s
Connecting pipes	2	2
Service pipes: Parts with poor drag reducing passage armatures (< 2.5) *	5	2
Parts with passage armatures with a higher correction value loss **	2.5	2

* i. e. piston valves acc. to DIN 3500. ball cock. inclined valves acc. to DIN 3502 (from DN 20)

** i. e. screw-down stop globe valves acc. to DIN 3512

Principles of calculation

To determine the pipe diameter in potable water networks of buildings numerous principles of calculation are necessary. The revised version of DIN 1988 provides a simplified and differentiated method of calculation.

The simplified method is suitable for clearly arranged pipes i. e. in residential buildings. The differentiated method includes all pipes and local resistances and offers the highest accuracy as well as the most accurate approximation of real operating conditions. The determining of the pipe diameter requires the following data:

- Minimum gauge pressure of supply or pressure in flow direction behind pressure reducing or boosting valve
- Head variations
- Pressure loss due to apparatus i. e. watermeter, filter, softening installations etc.
- Minimum flow pressure of the water point applied
- Pipe friction factor of the used pipe material
- Coefficients of loss for fittings and pipe connections

Calculation guide / Software

The potable water network calculation acc. to DIN 1988 is normally made with the assistance of software.

aquatherm offers the independent and easy to use calculation programm "liNear", which can be ordered directly with - or without - training at aquatherm.

For our Dendrit-Customers:

aquatherm naturally still offers you qualified support with your Dendrit-Software.

For both, liNear and Dendrit, please call our information service:

+ 49(0)2722 950-111/-116

We like to help you!



Minimum flow pressure

Calculated flows of common water points

Minimum flow pressure $P_{\min FI}$	Type of water point		Calculated flow on taking:		
			mixed water ¹⁾		only cold or heated potable water
			V_R cold	V_R warm	V_R
bar	Designation		l/s	l/s	l/s
	Taps				
0.5	without air inlet (airator) ²⁾	DN 15	-	-	0.30
0.5	without air inlet (airator) ²⁾	DN 20	-	-	0.50
0.5	without air inlet (airator) ²⁾	DN 25	-	-	1.00
1.0	with air inlet (airator)	DN 10	-	-	0.15
1.0	with air inlet (airator)	DN 15	-	-	0.15
1.0	Shower heads for purification showers	DN 15	0.10	0.10	0.20
1.2	Flush valves acc. to DIN 3265 Part 1	DN 15	-	-	0.70
1.2		DN 20	-	-	1.00
0.4		DN 25	-	-	1.00
1.0	Flush valves urinals	DN 15	-	-	0.30
1.0	Domestic dish washers	DN 15	-	-	0.15
1.0	Domestic washing machine	DN 15	-	-	0.25
	Mixing battery for:				
1.0	Shower-bathes	DN 15	0.15	0.15	-
1.0	Bath-tubs	DN 15	0.15	0.15	-
1.0	Kitchen sinks	DN 15	0.07	0.07	-
1.0	Washstands	DN 15	0.07	0.07	-
1.0	Bidets	DN 15	0.07	0.07	-
1.0	Mixing battery	DN 20	0.30	0.30	-
0.5	Flushing- box DIN 19542	DN 15	-	-	0.13
1.0	Electro boiler	DN 15	-	-	0.10 ³⁾

Comment:

All other water points and apparatus of the above type with larger armature passages or minimum pressures of flow have to be considered with determining the pipe diameter acc. to the manufacturer`s instructions.

¹⁾ The calculated flows of mixed water points are based on 15 °C for cold potable water and 60 °C for hot potable water.

²⁾ In case of taps without air inlet (airator) and with hose screw, the loss of pressure in the hose pipe (up to 10 m length) and in the connected apparatus (i.e. lawn sprinkler) is considered over the minimum pressure of flow. The minimum pressure of flow is increased by 1.0 bar to 1.5 bar.

³⁾ In case of fully opened flow control valve.

Minimum flow pressure

Determination of the peak flow rate V_S from the total flow $\sum V_R$ for buildings

acc. to DIN 1988 Teil 3 $V_S = 0.682 \cdot (\sum V_R)^{0.45} - 0.14$ [l/s]

$\sum V_R$	V_S	$\sum V_R$	V_S	$\sum V_R$	V_S	$\sum V_R$	V_S	$\sum V_R$	V_S	$\sum V_R$	V_S	$\sum V_R$	V_S	$\sum V_R$	V_S
0.03	0.00	1.02	0.55	2.02	0.80	3.02	0.98	4.02	1.14	5.10	1.28	10.10	1.79	15.10	2.17
0.04	0.02	1.04	0.55	2.04	0.80	3.04	0.98	4.04	1.14	5.20	1.29	10.20	1.80	15.20	2.18
0.06	0.05	1.06	0.56	2.06	0.80	3.06	0.99	4.06	1.14	5.30	1.30	10.30	1.81	15.30	2.19
0.07	0.07	1.08	0.57	2.08	0.81	3.08	0.99	4.08	1.14	5.40	1.32	10.40	1.82	15.40	2.19
0.08	0.08	1.10	0.57	2.10	0.81	3.10	0.99	4.10	1.15	5.50	1.33	10.50	1.82	15.50	2.20
0.09	0.09	1.12	0.58	2.12	0.82	3.12	1.00	4.12	1.15	5.60	1.34	10.60	1.83	15.60	2.21
0.10	0.10	1.14	0.58	2.14	0.82	3.14	1.00	4.14	1.15	5.70	1.35	10.70	1.84	15.70	2.21
0.13	0.13	1.16	0.59	2.16	0.82	3.16	1.00	4.16	1.16	5.80	1.36	10.80	1.85	15.80	2.22
0.15	0.15	1.18	0.59	2.18	0.83	3.18	1.01	4.18	1.16	5.90	1.38	10.90	1.86	15.90	2.23
0.20	0.19	1.20	0.60	2.20	0.83	3.20	1.01	4.20	1.16	6.00	1.39	11.00	1.87	16.00	2.23
0.22	0.21	1.22	0.61	2.22	0.84	3.22	1.01	4.22	1.16	6.10	1.40	11.10	1.87	16.10	2.24
0.24	0.22	1.24	0.61	2.24	0.84	3.24	1.02	4.24	1.17	6.20	1.41	11.20	1.88	16.20	2.25
0.26	0.23	1.26	0.62	2.26	0.84	3.26	1.02	4.26	1.17	6.30	1.42	11.30	1.89	16.30	2.25
0.28	0.24	1.28	0.62	2.28	0.85	3.28	1.02	4.28	1.17	6.40	1.43	11.40	1.90	16.40	2.26
0.30	0.26	1.30	0.63	2.30	0.85	3.30	1.03	4.30	1.17	6.50	1.44	11.50	1.91	16.50	2.27
0.32	0.27	1.32	0.63	2.32	0.86	3.32	1.03	4.32	1.18	6.60	1.45	11.60	1.91	16.60	2.27
0.34	0.28	1.34	0.64	2.34	0.86	3.34	1.03	4.34	1.18	6.70	1.47	11.70	1.92	16.70	2.28
0.36	0.29	1.36	0.64	2.36	0.86	3.36	1.04	4.36	1.18	6.80	1.48	11.80	1.93	16.80	2.29
0.38	0.30	1.38	0.65	2.38	0.87	3.38	1.04	4.38	1.19	6.90	1.49	11.90	1.94	16.90	2.29
0.40	0.31	1.40	0.65	2.40	0.87	3.40	1.04	4.40	1.19	7.00	1.50	12.00	1.95	17.00	2.30
0.42	0.32	1.42	0.66	2.42	0.88	3.42	1.05	4.42	1.19	7.10	1.51	12.10	1.95	17.10	2.31
0.44	0.33	1.44	0.66	2.44	0.88	3.44	1.05	4.44	1.19	7.20	1.52	12.20	1.96	17.20	2.31
0.46	0.34	1.46	0.67	2.46	0.88	3.46	1.05	4.46	1.20	7.30	1.53	12.30	1.97	17.30	2.32
0.48	0.35	1.48	0.67	2.48	0.89	3.48	1.06	4.48	1.20	7.40	1.54	12.40	1.98	17.40	2.33
0.50	0.36	1.50	0.68	2.50	0.89	3.50	1.06	4.50	1.20	7.50	1.55	12.50	1.99	17.50	2.33
0.52	0.37	1.52	0.68	2.52	0.89	3.52	1.06	4.52	1.20	7.60	1.56	12.60	1.99	17.60	2.34
0.54	0.38	1.54	0.69	2.54	0.90	3.54	1.06	4.54	1.21	7.70	1.57	12.70	2.00	17.70	2.35
0.56	0.39	1.56	0.69	2.56	0.90	3.56	1.07	4.56	1.21	7.80	1.58	12.80	2.01	17.80	2.35
0.58	0.39	1.58	0.70	2.58	0.90	3.58	1.07	4.58	1.21	7.90	1.59	12.90	2.02	17.90	2.36
0.60	0.40	1.60	0.70	2.60	0.91	3.60	1.07	4.60	1.22	8.00	1.60	13.00	2.02	18.00	2.36
0.62	0.41	1.62	0.71	2.62	0.91	3.62	1.08	4.62	1.22	8.10	1.61	13.10	2.03	18.10	2.37
0.64	0.42	1.64	0.71	2.64	0.92	3.64	1.08	4.64	1.22	8.20	1.62	13.20	2.04	18.20	2.38
0.66	0.43	1.66	0.72	2.66	0.92	3.66	1.08	4.66	1.22	8.30	1.63	13.30	2.05	18.30	2.38
0.68	0.43	1.68	0.72	2.68	0.92	3.68	1.09	4.68	1.23	8.40	1.64	13.40	2.05	18.40	2.39
0.70	0.44	1.70	0.73	2.70	0.93	3.70	1.09	4.70	1.23	8.50	1.65	13.50	2.06	18.50	2.40
0.72	0.45	1.72	0.73	2.72	0.93	3.72	1.09	4.72	1.23	8.60	1.66	13.60	2.07	18.60	2.40
0.74	0.46	1.74	0.74	2.74	0.93	3.74	1.09	4.74	1.23	8.70	1.67	13.70	2.07	18.70	2.41
0.76	0.46	1.76	0.74	2.76	0.94	3.76	1.10	4.76	1.24	8.80	1.67	13.80	2.08	18.80	2.41
0.78	0.47	1.78	0.74	2.78	0.94	3.78	1.10	4.78	1.24	8.90	1.68	13.90	2.09	18.90	2.42
0.80	0.48	1.80	0.75	2.80	0.94	3.80	1.10	4.80	1.24	9.00	1.69	14.00	2.10	19.00	2.43
0.82	0.48	1.82	0.75	2.82	0.95	3.82	1.11	4.82	1.24	9.10	1.70	14.10	2.10	19.10	2.43
0.84	0.49	1.84	0.76	2.84	0.95	3.84	1.11	4.84	1.25	9.20	1.71	14.20	2.11	19.20	2.44
0.86	0.50	1.86	0.76	2.86	0.95	3.86	1.11	4.86	1.25	9.30	1.72	14.30	2.21	19.30	2.44
0.88	0.50	1.88	0.77	2.88	0.96	3.88	1.12	4.88	1.25	9.40	1.73	14.40	2.12	19.40	2.45
0.90	0.51	1.90	0.77	2.90	0.96	3.90	1.12	4.90	1.25	9.50	1.74	14.50	2.13	19.50	2.46
0.92	0.52	1.92	0.77	2.92	0.96	3.92	1.12	4.92	1.26	9.60	1.75	14.60	2.14	19.60	2.46
0.94	0.52	1.94	0.78	2.94	0.97	3.94	1.12	4.94	1.26	9.70	1.76	14.70	2.15	19.70	2.47
0.96	0.53	1.96	0.78	2.96	0.97	3.96	1.13	4.96	1.26	9.80	1.76	14.80	2.15	19.80	2.47
0.98	0.54	1.98	0.79	2.98	0.97	3.98	1.13	4.98	1.26	9.90	1.77	14.90	2.16	19.90	2.48
1.00	0.54	2.00	0.79	3.00	0.98	4.00	1.13	5.00	1.27	10.00	1.78	15.00	2.17	20.00	2.49

This table is valid, if the calculated flow V_R of the respective water points is less than 0.5 l/s.

Minimum flow pressure

Determination of the peak flow rate V_S from the total flow ΣV_R for buildings

acc. to DIN 1988 Teil 3 $V_S = 1.7 \cdot (\Sigma V_R)^{0.21} - 0.7$ [l/s]

ΣV_R	V_S	ΣV_R	V_S	ΣV_R	V_S	ΣV_R	V_S	ΣV_R	V_S	ΣV_R	V_S	ΣV_R	V_S	ΣV_R	V_S
1.00	1.00	5.10	1.69	10.10	2.06	15.10	2.31	22.40	2.57	142.20	4.12	262.40	4.78	382.40	5.23
1.05	1.02	5.20	1.70	10.20	2.07	15.20	2.31	24.80	2.64	144.80	4.13	264.80	4.79	384.80	5.23
1.10	1.03	5.30	1.71	10.30	2.07	15.30	2.31	27.20	2.70	147.20	4.15	267.20	4.81	387.20	5.24
1.15	1.05	5.40	1.72	10.40	2.08	15.40	2.32	29.60	2.76	149.60	4.17	269.60	4.81	389.60	5.25
1.20	1.07	5.50	1.73	10.50	2.09	15.50	2.32	32.00	2.82	152.00	4.18	272.00	4.82	392.00	5.26
1.25	1.08	5.60	1.74	10.60	2.09	15.60	2.33	34.40	2.87	154.40	4.20	274.40	4.83	394.40	5.26
1.30	1.10	5.70	1.75	10.70	2.10	15.70	2.33	36.80	2.92	156.80	4.21	276.80	4.84	396.80	5.27
1.35	1.11	5.80	1.76	10.80	2.10	15.80	2.34	39.20	2.97	159.20	4.23	279.20	4.85	399.20	5.28
1.40	1.12	5.90	1.77	10.90	2.11	15.90	2.34	41.60	3.02	161.60	4.25	281.60	4.86	401.60	5.29
1.45	1.14	6.00	1.78	11.0	2.11	16.00	2.34	44.00	3.06	164.00	4.26	284.00	4.87	404.00	5.29
1.50	1.15	6.10	1.79	11.10	2.12	16.10	2.35	46.40	3.11	166.40	4.28	286.40	4.88	406.40	5.30
1.55	1.16	6.20	1.79	11.20	2.12	16.20	2.35	48.80	3.15	168.80	4.29	288.80	4.89	408.80	5.31
1.60	1.18	6.30	1.80	11.30	2.13	16.30	2.35	51.20	3.19	171.20	4.31	291.20	4.90	411.20	5.32
1.65	1.19	6.40	1.81	11.40	2.13	16.40	2.36	53.60	3.22	173.60	4.32	293.60	4.91	413.60	5.32
1.70	1.20	6.50	1.82	11.50	2.14	16.50	2.36	56.00	3.26	176.00	4.34	296.00	4.92	416.00	5.33
1.75	1.21	6.60	1.83	11.60	2.14	16.60	2.37	58.40	3.29	178.40	4.35	298.40	4.93	418.40	5.34
1.80	1.22	6.70	1.83	11.70	2.15	16.70	2.37	60.80	3.33	180.80	4.36	300.80	4.93	420.80	5.35
1.85	1.23	6.80	1.84	11.80	2.15	16.80	2.37	63.20	3.36	183.20	4.38	303.20	4.94	423.20	5.35
1.90	1.25	6.90	1.85	11.90	2.16	16.90	2.38	65.60	3.39	185.60	4.36	305.60	4.95	425.60	5.36
2.00	1.27	7.00	1.86	12.00	2.16	17.00	2.38	68.00	3.42	188.00	4.41	308.00	4.96	428.00	5.37
2.10	1.29	7.10	1.87	12.10	2.17	17.10	2.39	70.40	3.45	190.40	4.42	310.40	4.97	430.40	5.38
2.20	1.31	7.20	1.87	12.20	2.17	17.20	2.39	72.80	3.48	192.80	4.43	312.80	4.98	432.80	5.38
2.30	1.32	7.30	1.88	12.30	2.18	17.30	2.39	75.20	3.51	195.20	4.45	315.20	4.99	435.20	5.39
2.40	1.34	7.40	1.89	12.40	2.18	17.40	2.40	77.60	3.54	197.60	4.46	317.60	5.00	437.60	5.40
2.50	1.36	7.50	1.90	12.50	2.19	17.50	2.40	80.00	3.57	200.00	4.47	320.00	5.01	440.00	5.40
2.60	1.38	7.60	1.90	12.60	2.19	17.60	2.40	82.40	3.59	202.40	4.49	322.40	5.02	442.40	5.41
2.70	1.39	7.70	1.91	12.70	2.20	17.70	2.41	84.80	3.62	204.80	4.50	324.80	5.03	444.80	5.42
2.80	1.41	7.80	1.92	12.80	2.20	17.80	2.41	87.20	3.64	207.20	4.51	327.20	5.04	447.20	5.42
2.90	1.43	7.90	1.92	12.90	2.21	17.90	2.42	89.60	3.67	209.60	4.52	329.60	5.04	452.00	5.43
3.00	1.44	8.00	1.93	13.00	2.21	18.00	2.42	92.00	3.69	212.00	4.54	332.00	5.05	454.40	5.44
3.10	1.46	8.10	1.94	13.10	2.22	18.10	2.42	94.40	3.72	214.40	4.55	334.40	5.06	456.80	5.44
3.20	1.47	8.20	1.94	13.20	2.22	18.20	2.43	96.80	3.74	216.80	4.56	336.80	5.07	459.20	5.45
3.30	1.48	8.30	1.95	13.30	2.23	18.30	2.43	99.20	3.76	219.20	4.57	339.20	5.08	461.60	5.46
3.40	1.50	8.40	1.96	13.40	2.23	18.40	2.43	101.60	3.79	221.60	4.58	341.60	5.09	464.00	5.47
3.50	1.51	8.50	1.96	13.50	2.24	18.50	2.44	104.00	3.81	224.00	4.60	344.00	5.10	466.40	5.47
3.60	1.52	8.60	1.97	13.60	2.24	18.60	2.44	106.40	3.83	226.40	4.61	346.40	5.10	468.80	5.48
3.70	1.54	8.70	1.98	13.70	2.25	18.70	2.44	108.80	3.85	228.80	4.62	348.80	5.11	471.20	5.49
3.80	1.55	8.80	1.98	13.80	2.25	18.80	2.45	111.20	3.87	231.20	4.63	351.20	5.12	473.60	5.49
3.90	1.56	8.90	1.99	13.90	2.25	18.90	2.45	113.60	3.89	233.60	4.64	353.60	5.13	476.00	5.50
4.00	1.57	9.00	2.00	14.00	2.26	19.00	2.45	116.00	3.91	236.00	4.66	356.00	5.14	478.40	5.51
4.10	1.59	9.10	2.00	14.10	2.26	19.10	2.46	118.40	3.93	238.40	4.67	358.40	5.15	480.80	5.51
4.20	1.60	9.20	2.01	14.20	2.27	19.20	2.46	120.80	3.95	240.80	4.68	360.80	5.15	483.20	5.52
4.30	1.61	9.30	2.02	14.30	2.27	19.30	2.47	123.20	3.97	243.20	4.69	363.20	5.16	485.60	5.52
4.40	1.62	9.40	2.02	14.40	2.28	19.40	2.47	125.60	3.99	245.60	4.70	365.00	5.17	488.00	5.53
4.50	1.63	9.50	2.03	14.50	2.28	19.50	2.47	128.00	4.01	248.00	4.71	368.00	5.18	490.40	5.54
4.60	1.64	9.60	2.03	14.60	2.29	19.60	2.48	130.40	4.03	250.40	4.72	370.40	5.19	492.40	5.54
4.70	1.65	9.70	2.04	14.70	2.29	19.70	2.48	132.80	4.05	252.80	4.763	372.80	5.19	492.80	5.55
4.80	1.66	9.80	2.05	14.80	2.29	19.80	2.48	135.20	4.06	255.20	4.74	375.20	5.20	495.20	5.56
4.90	1.67	9.90	2.05	14.90	2.30	19.90	2.49	137.60	4.08	257.60	4.75	377.60	5.21	497.60	5.56
5.00	1.68	10.00	2.06	15.00	2.30	20.00	2.49	140.00	4.10	260.00	4.77	380.00	5.22	500.00	5.57

This table is valid, if the calculated flow V_R of the respective water points is more than 0.5 l/s.

Pipe friction factor R and calculated flow rate v in dependence on the volumetric current V̇

fusiotherm®-Pipe SDR 11

Temperature: 20 °C

Roughness: 0.0070 mm Density: 998.2 kg/m³ Viscosity: 1.004 x 10⁻⁶ m²/s

V̇		Di- men- sion	20.0 mm	25.0 mm	32.0 mm	40.0 mm	50.0 mm	63.0 mm	75.0 mm	90.0 mm	110.0 mm	125.0 mm	160.0 mm	200.0 mm	250.0 mm
0.01 l/s	0.60 l/min	R	0.05	0.02	0.01	0.00	0.00	0.00	0.00	0.00	0.00	0.00	0.00	0.00	0.00
		v	0.05	0.03	0.02	0.01	0.01	0.01	0.00	0.00	0.00	0.00	0.00	0.00	0.00
0.02 l/s	1.20 l/min	R	0.16	0.05	0.02	0.01	0.00	0.00	0.00	0.00	0.00	0.00	0.00	0.00	0.00
		v	0.01	0.06	0.04	0.02	0.02	0.00	0.01	0.01	0.00	0.00	0.00	0.00	0.00
0.03 l/s	1.80 l/min	R	0.31	0.10	0.03	0.01	0.00	0.00	0.00	0.00	0.00	0.00	0.00	0.00	0.00
		v	0.15	0.09	0.06	0.04	0.02	0.01	0.01	0.01	0.01	0.01	0.00	0.00	0.00
0.04 l/s	2.40 l/min	R	0.50	0.17	0.05	0.02	0.01	0.00	0.00	0.00	0.00	0.00	0.00	0.00	0.00
		v	0.19	0.12	0.07	0.05	0.03	0.02	0.01	0.01	0.01	0.01	0.01	0.00	0.00
0.05 l/s	3.00 l/min	R	0.74	0.25	0.08	0.03	0.00	0.00	0.00	0.00	0.00	0.00	0.00	0.00	0.00
		v	0.24	0.15	0.09	0.06	0.04	0.02	0.02	0.02	0.01	0.01	0.01	0.00	0.00
0.06 l/s	3.60 l/min	R	1.01	0.34	0.10	0.04	0.01	0.00	0.00	0.00	0.00	0.00	0.00	0.00	0.00
		v	0.29	0.18	0.11	0.07	0.05	0.03	0.02	0.01	0.01	0.01	0.01	0.00	0.00
0.07 l/s	4.20 l/min	R	1.31	0.44	0.14	0.05	0.02	0.01	0.00	0.00	0.00	0.00	0.00	0.00	0.00
		v	0.34	0.21	0.13	0.08	0.05	0.03	0.02	0.02	0.01	0.01	0.01	0.01	0.00
0.08 l/s	4.80 l/min	R	1.65	0.55	0.17	0.06	0.02	0.01	0.00	0.00	0.00	0.00	0.00	0.00	0.00
		v	0.39	0.24	0.15	0.01	0.06	0.04	0.03	0.02	0.01	0.00	0.01	0.00	0.00
0.09 l/s	5.40 l/min	R	2.03	0.68	0.21	0.07	0.03	0.01	0.00	0.00	0.00	0.00	0.00	0.00	0.00
		v	0.44	0.28	0.17	0.11	0.07	0.04	0.03	0.02	0.01	0.01	0.01	0.01	0.00
0.10 l/s	6.00 l/min	R	2.43	0.81	0.25	0.09	0.03	0.01	0.01	0.00	0.00	0.00	0.00	0.00	0.00
		v	0.49	0.31	0.19	0.12	0.08	0.05	0.03	0.02	0.02	0.01	0.01	0.01	0.01
0.12 l/s	7.20 l/min	R	3.35	1.12	0.34	0.12	0.04	0.01	0.01	0.00	0.00	0.00	0.00	0.00	0.00
		v	0.58	0.37	0.22	0.14	0.09	0.06	0.04	0.03	0.02	0.01	0.01	0.01	0.01
0.16 l/s	9.60 l/min	R	5.54	1.84	0.56	0.20	0.07	0.02	0.01	0.00	0.00	0.00	0.00	0.00	0.00
		v	0.78	0.49	0.30	0.19	0.12	0.08	0.05	0.04	0.03	0.02	0.01	0.01	0.01
0.18 l/s	10.8 l/min	R	6.82	2.27	0.69	0.24	0.08	0.03	0.01	0.01	0.00	0.00	0.00	0.00	0.00
		v	0.87	0.55	0.33	0.22	0.14	0.09	0.06	0.04	0.03	0.02	0.01	0.01	0.01
0.20 l/s	12.0 l/min	R	8.22	2.73	0.83	0.29	0.10	0.03	0.01	0.01	0.00	0.00	0.00	0.00	0.00
		v	0.97	0.61	0.37	0.24	0.15	0.01	0.07	0.05	0.03	0.02	0.01	0.00	0.01
0.30 l/s	18.0 l/min	R	16.90	5.57	1.68	0.59	0.20	0.07	0.03	0.01	0.01	0.00	0.00	0.00	0.00
		v	1.46	0.92	0.56	0.36	0.23	0.14	0.10	0.07	0.05	0.04	0.02	0.01	0.01
0.40 l/s	24.0 l/min	R	28.31	9.30	2.80	0.98	0.34	0.11	0.05	0.02	0.01	0.00	0.00	0.00	0.00
		v	1.94	1.22	0.74	0.48	0.31	0.19	0.14	0.09	0.06	0.05	0.03	0.02	0.01
0.50 l/s	30.0 l/min	R	42.36	13.86	4.15	1.46	0.50	0.17	0.07	0.03	0.01	0.01	0.00	0.00	0.00
		v	2.43	1.53	0.93	0.60	0.38	0.24	0.17	0.12	0.08	0.06	0.04	0.02	0.02
0.60 l/s	36.0 l/min	R	58.99	19.24	5.75	2.01	0.69	0.23	0.01	0.04	0.02	0.01	0.00	0.00	0.00
		v	2.91	1.84	1.11	0.72	0.46	0.29	0.20	0.14	0.09	0.07	0.04	0.03	0.02
0.70 l/s	42.0 l/min	R	78.16	25.41	7.57	2.65	0.90	0.30	0.13	0.05	0.02	0.01	0.00	0.00	0.00
		v	3.40	2.14	1.30	0.84	0.54	0.34	0.24	0.16	0.11	0.09	0.05	0.03	0.02
0.80 l/s	48.0 l/min	R	99.83	32.37	9.62	3.36	1.14	0.38	0.16	0.07	0.03	0.01	0.00	0.00	0.00
		v	3.88	2.45	1.48	0.96	0.61	0.39	0.27	0.19	0.13	0.01	0.06	0.04	0.02

V̇ = Volumetric current [l/s] R = Pressure gradient [mbar/m] v = Flow rate [m/s]

Pipe friction factor R and calculated flow rate \dot{V} in dependence on the volumetric current \dot{V}

fusiotherm®-pipe SDR 11

Temperature: 20 °C

Roughness: 0.0070 mm Density: 998.2 kg/m³ Viscosity: 1.004 x 10⁻⁶ m²/s

\dot{V}		Di- men- sion	20.0 mm	25.0 mm	32.0 mm	40.0 mm	50.0 mm	63.0 mm	75.0 mm	90.0 mm	110.0 mm	125.0 mm	160.0 mm	200.0 mm	250.0 mm
0.90	54.0	R	123.97	40.10	11.90	4.14	1.41	0.47	0.20	0.08	0.03	0.02	0.01	0.00	0.00
	l/min	v	4.37	2.75	1.67	1.08	0.69	0.43	0.30	0.21	0.14	0.11	0.07	0.04	0.03
1.00	60.0	R	150.58	48.60	14.39	5.00	1.70	0.56	0.24	0.10	0.04	0.02	0.01	0.00	0.00
	l/min	v	4.85	3.06	1.85	1.20	0.76	0.48	0.34	0.24	0.16	0.12	0.07	0.05	0.03
1.20	72.0	R	211.10	67.87	20.02	6.94	2.35	0.78	0.33	0.14	0.05	0.03	0.01	0.00	0.00
	l/min	v	5.82	3.67	2.23	1.44	0.92	0.58	0.41	0.28	0.19	0.15	0.09	0.06	0.04
1.40	84.0	R	281.32	90.12	26.49	9.17	3.10	1.02	0.44	0.18	0.07	0.04	0.01	0.00	0.00
	l/min	v	6.79	4.28	2.60	1.68	1.07	0.67	0.47	0.33	0.22	0.17	0.10	0.07	0.04
1.60	96.0	R	361.15	115.34	33.81	11.67	3.94	1.30	0.55	0.23	0.09	0.05	0.01	0.01	0.00
	l/min	v	7.76	4.90	2.97	1.92	1.22	0.77	0.54	0.38	0.25	0.20	0.12	0.08	0.05
1.80	108	R	450.55	143.49	41.95	14.45	4.87	1.60	0.68	0.29	0.11	0.06	0.02	0.01	0.00
	l/min	v	8.73	5.51	3.34	2.16	1.38	0.87	0.61	0.42	0.28	0.22	0.13	0.09	0.05
2.00	120	R	549.50	174.56	50.90	17.51	5.89	1.93	0.82	0.34	0.13	0.07	0.02	0.01	0.00
	l/min	v	9.70	6.12	3.71	2.40	1.53	0.96	0.68	0.47	0.31	0.24	0.15	0.01	0.06
2.20	132	R	657.95	208.53	60.67	20.83	7.00	2.29	0.98	0.41	0.16	0.08	0.03	0.01	0.00
	l/min	v	10.67	6.73	4.08	2.64	1.68	1.06	0.74	0.52	0.35	0.27	0.16	0.10	0.07
2.40	144	R	775.89	245.39	71.25	24.42	8.20	2.68	1.14	0.48	0.18	0.01	0.03	0.01	0.00
	l/min	v	11.64	7.34	4.45	2.88	1.84	1.16	0.81	0.56	0.38	0.29	0.18	0.11	0.07
2.60	156	R	903.30	285.14	82.62	28.28	9.48	3.01	1.32	0.55	0.21	0.11	0.04	0.01	0.00
	l/min	v	12.61	7.95	4.82	3.11	1.99	1.25	0.88	0.61	0.41	0.32	0.19	0.12	0.08
2.80	168	R	1040.16	327.76	94.79	32.40	10.85	3.54	1.50	0.63	0.24	0.13	0.04	0.01	0.01
	l/min	v	13.58	8.57	5.19	3.35	2.14	1.35	0.95	0.66	0.44	0.34	0.21	0.13	0.09
3.00	180	R	1186.48	373.24	107.76	36.78	12.30	4.01	1.70	0.71	0.27	0.15	0.05	0.02	0.01
	l/min	v	14.55	9.18	5.56	3.59	2.29	1.45	1.01	0.71	0.47	0.37	0.22	0.14	0.09
3.20	192	R	1342.23	421.59	121.52	41.42	13.84	4.51	1.91	0.80	0.30	0.17	0.05	0.02	0.01
	l/min	v	15.52	9.79	5.94	3.83	2.45	1.54	1.08	0.75	0.50	0.39	0.24	0.15	0.01
3.40	204	R	1507.41	472.79	136.07	46.33	15.46	5.03	2.13	0.89	0.34	0.18	0.06	0.02	0.01
	l/min	v	16.50	10.40	6.31	4.07	2.60	1.64	1.15	0.80	0.53	0.41	0.25	0.16	0.10
3.60	216	R	1682.01	526.85	151.41	51.49	17.16	5.58	2.36	0.99	0.37	0.20	0.06	0.02	0.01
	l/min	v	17.47	11.01	6.68	4.31	2.75	1.73	1.22	0.85	0.57	0.44	0.27	0.17	0.11
3.80	228	R	1866.03	583.75	167.53	56.91	18.95	6.16	2.60	1.09	0.41	0.22	0.07	0.02	0.01
	l/min	v	18.44	11.63	7.05	4.55	2.91	1.83	1.28	0.89	0.60	0.46	0.28	0.18	0.12
4.00	240	R	2059.46	643.50	184.44	62.58	20.82	6.76	2.86	1.19	0.45	0.25	0.08	0.03	0.01
	l/min	v	19.41	12.24	7.42	4.79	3.06	1.93	1.35	0.94	0.63	0.49	0.30	0.19	0.12
4.20	252	R	2262.30	706.09	202.12	68.51	22.77	7.39	3.12	1.30	0.49	0.27	0.08	0.03	0.00
	l/min	v	20.38	12.85	7.79	5.03	3.21	2.02	1.42	0.99	0.66	0.51	0.31	0.20	0.13
4.40	264	R	2474.55	771.52	220.59	74.70	24.81	8.04	3.40	1.41	0.54	0.29	0.09	0.03	0.01
	l/min	v	21.35	13.46	8.16	5.27	3.37	2.12	1.49	1.03	0.69	0.54	0.33	0.21	0.13
4.60	276	R	2696.19	839.79	239.84	81.14	26.92	8.72	3.68	1.53	0.58	0.32	0.01	0.03	0.01
	l/min	v	22.32	14.07	8.53	5.51	3.52	2.22	1.55	1.08	0.72	0.56	0.34	0.22	0.14

\dot{V} = Volumetric current [l/s]

R = Pressure gradient [mbar/m]

v = Flow rate [m/s]

Pipe friction factor R and calculated flow rate v in dependence on the volumetric current V̇

fusiotherm®-pipe SDR 11

Temperature: 20 °C

Roughness: 0.0070 mm Density: 998.2 kg/m³ Viscosity: 1.004 x 10⁻⁶ m²/s

V̇		Di- men- sion	20.0 mm	25.0 mm	32.0 mm	40.0 mm	50.0 mm	63.0 mm	75.0 mm	90.0 mm	110.0 mm	125.0 mm	160.0 mm	200.0 mm	250.0 mm
4.80 l/s	288 l/min	R	2927.24	910.89	259.86	87.84	29.12	9.43	3.98	1.65	0.63	0.34	0.10	0.04	0.01
		v	23.29	14.69	8.90	5.75	3.67	2.31	1.62	1.13	0.75	0.59	0.36	0.23	0.15
5.00 l/s	300 l/min	R	3167.68	984.83	280.67	94.79	31.40	10.16	4.28	1.78	0.68	0.37	0.11	0.04	0.01
		v	24.26	15.30	9.27	5.99	3.82	2.41	1.69	1.18	0.79	0.61	0.37	0.24	0.15
5.20 l/s	312 l/min	R	3417.51	1061.60	302.25	101.99	33.76	10.91	4.60	1.91	0.72	0.39	0.12	0.04	0.01
		v	25.23	15.91	9.65	6.23	3.98	2.51	1.76	1.22	0.82	0.63	0.39	0.25	0.16
5.40 l/s	324 l/min	R	3676.74	1141.21	324.60	109.44	36.20	11.69	4.93	2.05	0.78	0.42	0.13	0.04	0.02
		v	26.20	16.52	10.02	6.47	4.13	2.60	1.82	1.27	0.85	0.66	0.40	0.26	0.16
5.60 l/s	336 l/min	R	3945.36	1223.64	347.73	117.15	38.72	12.50	5.26	2.19	0.83	0.45	0.14	0.05	0.02
		v	27.17	17.13	10.39	6.71	4.28	2.70	1.89	1.32	0.88	0.68	0.42	0.27	0.17
5.80 l/s	348 l/min	R	4223.36	1308.90	371.63	125.10	41.32	13.33	5.61	2.33	0.88	0.48	0.15	0.05	0.02
		v	28.14	17.75	10.76	6.95	4.44	2.80	1.96	1.36	0.91	0.71	0.43	0.28	0.18
6.00 l/s	360 l/min	R	4510.76	1396.99	396.31	133.31	44.00	14.19	5.97	2.48	0.94	0.51	0.16	0.05	0.02
		v	29.11	18.36	11.13	7.19	4.59	2.89	2.03	1.41	0.94	0.73	0.45	0.29	0.18
6.20 l/s	372 l/min	R	4807.54	1487.91	421.76	141.77	46.76	15.07	6.34	2.63	0.99	0.54	0.16	0.06	0.02
		v	30.08	18.97	11.50	7.43	4.74	2.99	2.09	1.46	0.97	0.76	0.46	0.29	0.19
6.40 l/s	384 l/min	R	5113.71	1581.66	447.99	150.48	49.60	15.97	6.71	2.79	1.05	0.57	0.17	0.06	0.02
		v	31.05	19.58	11.87	7.67	4.90	3.08	2.16	1.50	1.01	0.78	0.48	0.30	0.19
6.60 l/s	396 l/min	R	5429.26	1678.23	474.98	159.44	52.52	16.90	7.10	2.95	1.11	0.60	0.18	0.06	0.02
		v	32.02	20.19	12.24	7.91	5.05	3.18	2.23	1.55	1.04	0.80	0.49	0.31	0.20
6.80 l/s	408 l/min	R	5754.19	1777.62	502.75	168.65	55.52	17.86	7.50	3.11	1.18	0.64	0.19	0.07	0.02
		v	32.99	20.80	12.61	8.15	5.20	3.28	2.30	1.60	1.07	0.83	0.51	0.32	0.21
7.00 l/s	420 l/min	R	6088.51	1879.84	531.29	178.11	58.59	18.84	7.91	3.28	1.24	0.67	0.20	0.07	0.02
		v	33.96	21.42	12.98	8.39	5.35	3.37	2.36	1.65	1.10	0.85	0.52	0.33	0.21
7.50 l/s	450 l/min	R	6965.36	2147.74	606.00	202.86	66.63	21.39	8.97	3.72	1.40	0.76	0.23	0.08	0.03
		v	36.39	22.95	13.91	8.99	5.74	3.61	2.53	1.76	1.18	0.91	0.56	0.36	0.23
8.00 l/s	480 l/min	R	7900.83	2433.28	685.53	229.16	75.17	24.10	10.10	4.18	1.58	0.85	0.26	0.09	0.03
		v	38.81	24.48	14.84	9.58	6.12	3.86	2.70	1.88	1.26	0.98	0.60	0.38	0.24
9.00 l/s	540 l/min	R	9947.63	3057.26	859.00	286.42	93.71	29.98	12.54	5.18	1.95	1.06	0.32	0.11	0.04
		v	43.66	27.54	16.69	10.78	6.88	4.34	3.04	2.12	1.41	1.01	0.67	0.43	0.27
10.0 l/s	600 l/min	R		3751.74	1051.68	349.88	114.21	36.45	15.23	6.29	2.37	1.28	0.39	0.13	0.05
		v		30.59	18.55	11.98	7.65	4.82	3.38	2.35	1.57	1.22	0.74	0.48	0.30
12.0 l/s	720 l/min	R		5352.08	1494.56	495.34	161.05	51.20	21.34	8.79	3.30	1.78	0.54	0.18	0.06
		v		36.71	22.26	14.38	9.18	5.78	4.05	2.82	1.89	1.46	0.89	0.57	0.36
14.0 l/s	840 l/min	R		7234.15	2014.06	665.47	215.64	68.33	28.40	11.67	4.37	2.36	0.71	0.24	0.08
		v		42.83	25.97	16.77	10.71	6.75	4.73	3.29	2.20	1.71	1.04	0.67	0.43
16.0 l/s	960 l/min	R			2610.11	860.21	277.95	87.81	36.43	14.94	5.59	3.01	0.91	0.31	0.11
		v			29.68	19.17	12.24	7.71	5.40	3.76	2.52	1.95	1.19	0.76	0.49
18.0 l/s	1080 l/min	R			3282.66	1079.54	347.96	109.65	45.40	18.59	6.94	3.73	1.13	0.38	0.13
		v			33.39	21.56	13.77	8.67	6.08	4.23	2.83	2.19	1.34	0.86	0.55

V̇ = Volumetric current [l/s] R = Pressure gradient [mbar/m] v = Flow rate [m/s]

Pipe friction factor R and calculated flow rate v in dependence on the volumetric current \dot{V}

fusiotherm®-pipe SDR 11

Temperature: 20 °C

Roughness: 0.0070 mm Density: 998.2 kg/m³ Viscosity: 1.004 x 10⁻⁶ m²/s

\dot{V}		Di- men- sion	20.0 mm	25.0 mm	32.0 mm	40.0 mm	50.0 mm	63.0 mm	75.0 mm	90.0 mm	110.0 mm	125.0 mm	160.0 mm	200.0 mm	250.0 mm
20.0 l/s	1200 l/min	R			4031.69	1323.42	425.65	133.82	55.31	22.61	8.43	4.53	1.37	0.46	0.16
	v				37.01	23.96	15.30	9.64	6.75	4.70	3.14	2.44	1.49	0.95	0.61
22.0 l/s	1320 l/min	R			4857.17	1591.85	511.00	160.32	66.16	27.00	10.05	5.40	1.62	0.55	0.19
	v				40.81	26.36	16.83	10.60	7.43	5.17	3.46	2.68	1.64	1.05	0.67
24.0 l/s	1440 l/min	R			5759.09	1884.80	604.03	189.14	77.94	31.77	11.81	6.34	1.90	0.64	0.22
	v				44.52	28.75	18.36	11.57	8.11	5.64	3.77	2.93	1.79	1.14	0.73
26.0 l/s	1560 l/min	R				2202.27	704.71	220.29	90.66	36.90	13.70	7.35	2.21	0.74	0.25
	v					31.15	19.89	12.53	8.78	6.11	4.09	3.17	1.93	1.24	0.79
28.0 l/s	1680 l/min	R				2544.25	813.03	253.75	104.30	42.40	15.72	8.42	2.53	0.85	0.29
	v					33.55	21.42	13.49	9.46	6.58	4.40	3.41	2.08	1.33	0.85
30.0 l/s	1800 l/min	R				2910.74	928.99	289.53	118.87	48.27	17.87	9.57	2.87	0.97	0.33
	v					35.94	22.95	14.46	10.13	7.05	4.72	3.66	2.23	1.43	0.91
32.0 l/s	1920 l/min	R				3301.73	1052.60	327.62	134.36	54.50	20.16	10.79	3.23	1.09	0.37
	v					38.34	24.48	15.42	10.81	7.52	5.03	3.90	2.38	1.52	0.97
34.0 l/s	2040 l/min	R				3717.22	1183.84	368.01	150.78	61.01	22.58	12.08	3.61	1.22	0.41
	v					40.73	26.01	16.39	11.48	7.99	5.34	4.14	2.53	1.62	1.03
36.0 l/s	2160 l/min	R				4157.20	1322.72	410.72	168.12	68.06	25.12	13.43	4.01	1.35	0.46
	v					43.13	27.54	17.35	12.16	8.46	5.66	4.39	2.68	1.71	1.09
38.0 l/s	2280 l/min	R					1469.23	455.73	186.38	75.38	27.80	14.85	4.43	1.49	0.50
	v						29.07	18.31	12.83	8.93	5.97	4.63	2.83	1.81	1.16
40.0 l/s	2400 l/min	R					1623.37	503.04	205.56	83.07	30.61	16.35	4.87	1.64	0.55
	v						30.59	19.28	13.51	9.40	6.29	4.88	2.98	1.90	1.22
42.0 l/s	2520 l/min	R					1785.14	552.66	225.65	91.12	33.54	17.90	5.33	1.79	0.60
	v						32.12	20.24	14.18	9.87	6.60	5.12	3.13	2.00	1.28
44.0 l/s	2640 l/min	R					1954.54	604.58	246.67	99.52	36.61	19.53	5.81	1.95	0.66
	v						33.65	21.20	14.86	10.34	6.92	5.36	3.27	2.09	1.34
46.0 l/s	2760 l/min	R					2131.56	658.80	268.61	108.29	39.80	21.22	6.31	2.12	0.71
	v						35.18	22.17	15.54	10.81	7.23	5.61	3.42	2.19	1.40
48.0 l/s	2880 l/min	R					2316.21	715.32	291.46	117.42	43.12	22.99	6.83	2.29	0.77
	v						36.71	23.13	16.21	11.28	7.55	5.85	3.57	2.28	1.46
50.0 l/s	3000 l/min	R					2508.48	774.14	315.22	126.91	46.58	24.81	7.37	2.47	0.83
	v						38.24	24.01	16.89	11.75	7.86	6.01	3.72	2.38	1.52
52.0 l/s	3120 l/min	R					2708.38	835.27	339.91	136.76	50.15	26.71	7.92	2.65	0.89
	v						39.77	25.06	17.56	12.22	8.17	6.34	3.87	2.47	1.58
54.0 l/s	3240 l/min	R					2915.90	898.68	365.51	146.97	53.86	28.67	8.50	2.84	0.96
	v						41.30	26.02	18.24	12.69	8.49	6.58	4.02	2.57	1.64
56.0 l/s	3360 l/min	R					3131.04	964.40	392.02	157.54	57.70	30.70	9.09	3.04	1.02
	v						42.83	26.99	18.91	13.16	8.80	6.83	4.17	2.66	1.70
58.0 l/s	3480 l/min	R					3353.80	1032.42	419.45	168.47	61.66	32.80	9.71	3.24	1.09
	v						44.36	27.95	19.59	13.63	9.12	7.07	4.32	2.76	1.76

\dot{V} = Volumetric current [l/s]

R = Pressure gradient [mbar/m]

v = Flow rate [m/s]

Pipe friction factor R and calculated flow rate v in dependence on the volumetric current \dot{V}

fusiotherm®-pipe SDR 11

Temperature: 20 °C

Roughness: 0.0070 mm Density: 998.2 kg/m³ Viscosity: 1.004 x 10⁻⁶ m²/s

\dot{V}		Di- men- sion	20.0 mm	25.0 mm	32.0 mm	40.0 mm	50.0 mm	63.0 mm	75.0 mm	90.0 mm	110.0 mm	125.0 mm	160.0 mm	200.0 m	250.0 mm
60.0 l/s	3600 l/min	R						1102.73	447.80	179.76	65.75	34.96	10.34	3.45	1.16
	v	v						28.92	20.26	14.10	9.43	7.31	4.47	2.85	1.82
62.0 l/s	3720 l/min	R						1175.34	477.06	191.40	69.97	37.19	10.99	3.67	1.23
	v	v						29.88	20.94	14.57	9.75	7.56	4.61	2.95	1.89
64.0 l/s	3840 l/min	R						1250.25	507.23	203.41	74.31	39.48	11.66	3.89	1.31
	v	v						30.84	21.61	15.04	10.06	7.80	4.76	3.04	1.95
66.0 l/s	3960 l/min	R						1327.46	538.32	215.77	78.78	41.84	12.35	4.12	1.38
	v	v						31.81	22.29	15.51	10.37	8.05	4.91	3.14	2.01
68.0 l/s	4080 l/min	R						1406.96	570.32	228.49	83.38	44.27	13.06	4.35	1.46
	v	v						32.77	22.97	15.98	10.69	8.29	5.06	3.23	2.07
70.0 l/s	4200 l/min	R						1488.75	603.24	241.56	88.11	46.77	13.79	4.59	1.54
	v	v						33.74	23.64	16.45	11.00	8.53	5.21	3.33	2.13
72.0 l/s	4320 l/min	R						1572.85	637.07	255.00	92.96	49.33	14.54	4.84	1.62
	v	v						34.70	24.32	16.92	11.32	8.78	5.36	3.43	2.19
74.0 l/s	4440 l/min	R						1659.23	671.81	268.79	97.94	51.95	15.30	5.09	1.71
	v	v						35.66	24.99	17.39	11.63	9.02	5.51	3.52	2.25
76.0 l/s	4560 l/min	R						1747.92	707.46	282.94	103.05	54.64	16.09	5.35	1.79
	v	v						36.63	25.67	17.86	11.95	9.26	5.66	3.62	2.31
78.0 l/s	4680 l/min	R						1838.90	744.03	297.45	108.28	57.40	16.89	5.62	1.88
	v	v						37.59	26.34	18.33	12.26	9.51	5.80	3.71	2.37
80.0 l/s	4800 l/min	R						1932.17	781.51	312.31	113.64	60.23	17.71	5.89	1.97
	v	v						38.55	27.02	18.80	12.58	9.75	5.95	3.81	2.43
85.0 l/s	5100 l/min	R						2175.40	879.21	351.04	127.59	67.58	19.85	6.59	2.21
	v	v						40.96	28.71	19.98	13.36	10.36	6.33	4.04	2.59
90.0 l/s	5400 l/min	R						2432.97	982.60	392.00	142.34	75.33	22.01	7.33	2.45
	v	v						43.37	30.40	21.15	14.15	10.97	6.70	4.28	2.74
95.0 l/s	5700 l/min	R							1091.70	435.18	157.87	83.50	24.47	8.11	2.71
	v	v							32.08	22.33	14.93	11.58	7.07	4.52	2.89
100.0 l/s	6000 l/min	R							1206.50	480.60	174.19	92.08	26.95	8.92	2.98
	v	v							33.77	23.50	15.72	12.19	7.44	4.76	3.04
105.0 l/s	6300 l/min	R							1327.00	528.24	191.30	101.07	29.55	9.78	3.26
	v	v							35.46	24.68	16.50	12.80	7.81	4.99	3.19

\dot{V} = Volumetric current [l/s] R = Pressure gradient [mbar/m] v = Flow rate [m/s]

Pipe friction factor R and calculated flow rate v in dependence on the volumetric current \dot{V}

fusiotherm®-pipe SDR 6

Temperature: 20 °C

Roughness: 0.0070 mm

Density: 998.2 kg/m³

Viscosity: 1.004 x 10⁻⁶ m²/s

\dot{V}		Di- men- sion	16.0 mm	20.0 mm	25.0 mm	32.0 mm	40.0 mm	50.0 mm	63.0 mm	75.0 mm	90.0 mm	110.0 mm
0.01 l/s	0.60 l/min	R	0.36	0.13	0.04	0.01	0.01	0.00	0.00	0.00	0.00	0.00
		v	0.11	0.07	0.05	0.03	0.02	0.01	0.01	0.01	0.00	0.00
0.02 l/s	1.20 l/min	R	1.14	0.41	0.14	0.04	0.02	0.01	0.00	0.00	0.00	0.00
		v	0.23	0.15	0.09	0.06	0.04	0.02	0.01	0.01	0.01	0.01
0.03 l/s	1.80 l/min	R	2.28	0.81	0.28	0.09	0.03	0.01	0.00	0.00	0.00	0.00
		v	0.34	0.22	0.14	0.08	0.05	0.03	0.02	0.02	0.01	0.01
0.04 l/s	2.40 l/min	R	3.73	1.32	0.45	0.14	0.05	0.02	0.01	0.00	0.00	0.00
		v	0.45	0.29	0.18	0.11	0.07	0.05	0.03	0.02	0.01	0.01
0.05 l/s	3.00 l/min	R	5.49	1.94	0.66	0.21	0.07	0.02	0.01	0.00	0.00	0.00
		v	0.57	0.37	0.23	0.14	0.09	0.06	0.04	0.03	0.02	0.01
0.06 l/s	3.60 l/min	R	7.54	2.66	0.90	0.28	0.09	0.03	0.01	0.01	0.00	0.00
		v	0.68	0.44	0.28	0.17	0.11	0.07	0.04	0.03	0.02	0.01
0.07 l/s	4.20 l/min	R	9.87	3.47	1.17	0.37	0.13	0.04	0.01	0.01	0.00	0.00
		v	0.79	0.51	0.32	0.20	0.13	0.08	0.05	0.04	0.02	0.02
0.08 l/s	4.80 l/min	R	12.47	4.38	1.47	0.46	0.16	0.05	0.02	0.01	0.00	0.00
		v	0.91	0.58	0.37	0.23	0.14	0.09	0.06	0.04	0.03	0.02
0.09 l/s	5.40 l/min	R	15.34	5.37	1.81	0.57	0.19	0.07	0.02	0.01	0.00	0.00
		v	1.02	0.66	0.42	0.25	0.16	0.10	0.06	0.05	0.03	0.02
0.10 l/s	6.00 l/min	R	18.47	6.46	2.17	0.68	0.23	0.08	0.03	0.01	0.01	0.00
		v	1.13	0.73	0.46	0.28	0.18	0.11	0.07	0.05	0.04	0.02
0.12 l/s	7.20 l/min	R	25.51	8.90	2.98	0.93	0.32	0.11	0.04	0.02	0.01	0.00
		v	1.36	0.88	0.55	0.34	0.22	0.14	0.09	0.06	0.04	0.03
0.16 l/s	9.60 l/min	R	42.60	14.79	4.93	1.54	0.52	0.18	0.06	0.03	0.01	0.00
		v	1.81	1.17	0.74	0.45	0.29	0.18	0.12	0.08	0.06	0.04
0.18 l/s	10.8 l/min	R	52.61	18.24	6.07	1.89	0.64	0.22	0.07	0.03	0.01	0.01
		v	2.04	1.32	0.83	0.51	0.32	0.21	0.13	0.09	0.06	0.04
0.20 l/s	12.0 l/min	R	63.59	22.00	7.31	2.27	0.77	0.26	0.09	0.04	0.02	0.01
		v	2.27	1.46	0.92	0.57	0.36	0.23	0.14	0.10	0.07	0.05
0.30 l/s	18.0 l/min	R	132.57	45.52	15.02	4.63	1.57	0.53	0.18	0.08	0.03	0.01
		v	3.40	2.19	1.39	0.85	0.54	0.34	0.22	0.15	0.11	0.07
0.40 l/s	24.0 l/min	R	224.51	76.63	25.16	7.73	2.60	0.88	0.29	0.13	0.05	0.02
		v	4.53	2.92	1.85	1.13	0.72	0.46	0.29	0.20	0.14	0.09
0.50 l/s	30.0 l/min	R	338.95	115.12	37.63	11.51	3.86	1.30	0.43	0.19	0.08	0.03
		v	5.67	3.65	2.31	1.42	0.90	0.57	0.36	0.25	0.18	0.12
0.60 l/s	36.0 l/min	R	475.62	160.87	52.38	15.97	5.34	1.79	0.60	0.26	0.11	0.04
		v	6.80	4.38	2.77	1.70	1.08	0.68	0.43	0.31	0.21	0.14
0.70 l/s	42.0 l/min	R	634.34	213.78	69.37	21.09	7.04	2.35	0.79	0.34	0.14	0.05
		v	7.93	5.12	3.23	1.98	1.26	0.80	0.51	0.36	0.25	0.17
0.80 l/s	48.0 l/min	R	814.99	273.78	88.57	26.85	8.94	2.99	1.00	0.43	0.18	0.07
		v	9.07	5.85	3.70	2.27	1.44	0.91	0.58	0.41	0.28	0.19

\dot{V} = Volumetric current [l/s]

R = Pressure gradient [mbar/m]

v = Flow rate [m/s]

Pipe friction factor R and calculated flow rate v in dependence on the volumetric current \dot{V}

fusiotherm®-pipe SDR 6

Temperature: 20 °C

Roughness: 0.0070 mm Density: 998.2 kg/m³ Viscosity: 1.004 x 10⁻⁶ m²/s

\dot{V}		Di- men- sion	16.0 mm	20.0 mm	25.0 mm	32.0 mm	40.0 mm	50.0 mm	63.0 mm	75.0 mm	90.0 mm	110.0 mm
0.90 l/s	54.0 l/min	R	1017.48	340.84	109.97	33.25	11.05	3.69	1.23	0.53	0.22	0.09
		v	10.20	6.58	4.16	2.55	1.62	1.03	0.65	0.46	0.32	0.21
1.00 l/s	60.0 l/min	R	1241.75	414.91	133.53	40.28	13.37	4.45	1.48	0.64	0.27	0.10
		v	11.33	7.31	4.62	2.83	1.80	1.14	0.72	0.51	0.35	0.24
1.20 l/s	72.0 l/min	R	1755.44	584.00	187.12	56.21	18.60	6.17	2.05	0.89	0.37	0.14
		v	13.60	8.77	5.54	3.40	2.16	1.37	0.87	0.61	0.42	0.28
1.40 l/s	84.0 l/min	R	2355.79	780.86	249.26	74.61	24.61	8.15	2.70	1.17	0.49	0.19
		v	15.86	10.23	6.47	3.97	2.52	1.60	1.01	0.71	0.50	0.33
1.60 l/s	96.0 l/min	R	3042.63	1005.40	319.89	95.44	31.40	10.38	3.43	1.48	0.62	0.24
		v	18.13	11.69	7.39	4.53	2.88	1.83	1.15	0.81	0.57	0.38
1.80 l/s	108 l/min	R	3815.83	1257.54	398.96	118.68	38.95	12.85	4.24	1.83	0.76	0.29
		v	20.40	13.15	8.32	5.01	3.24	2.05	1.30	0.92	0.64	0.43
2.00 l/s	120 l/min	R	4675.33	1537.22	486.44	144.32	47.26	15.56	5.12	2.21	0.92	0.35
		v	22.66	14.61	9.24	5.67	3.60	2.28	1.44	1.02	0.71	0.47
2.20 l/s	132 l/min	R	5621.05	1844.39	582.30	172.34	56.32	18.51	6.09	2.62	1.09	0.41
		v	24.93	16.08	10.17	6.23	3.96	2.51	1.59	1.12	0.78	0.52
2.40 l/s	144 l/min	R	6652.96	2179.03	686.53	202.74	66.13	21.70	7.12	3.07	1.27	0.48
		v	27.20	17.54	11.09	6.80	4.32	2.74	1.73	1.22	0.85	0.57
2.60 l/s	156 l/min	R	7771.02	2541.12	799.01	235.50	76.68	25.12	8.24	3.54	1.47	0.56
		v	29.46	19.00	12.01	7.37	4.68	2.97	1.88	1.32	0.92	0.61
2.80 l/s	168 l/min	R	8975.22	2930.62	920.01	270.62	87.97	28.78	9.42	4.05	1.68	0.64
		v	31.73	20.46	12.94	7.93	5.04	3.20	2.02	1.43	0.99	0.66
3.00 l/s	180 l/min	R	10265.53	3347.53	1049.24	308.09	100.00	32.66	10.68	4.59	1.90	0.72
		v	34.00	21.92	13.86	8.50	5.40	3.42	2.17	1.53	1.06	0.71
3.20 l/s	192 l/min	R	11641.93	3791.84	1186.78	347.91	112.75	36.78	12.02	5.15	2.13	0.81
		v	36.26	23.38	14.79	9.07	5.76	3.65	2.31	1.63	1.13	0.76
3.40 l/s	204 l/min	R	13104.41	4263.53	1332.63	390.07	126.24	41.13	13.42	5.75	2.38	0.90
		v	38.53	24.85	15.71	9.63	6.12	3.88	2.45	1.73	1.20	0.80
3.60 l/s	216 l/min	R	14652.97	4762.59	1486.78	434.56	140.46	45.71	14.90	6.38	2.64	1.00
		v	40.79	26.31	16.63	10.20	6.48	4.11	2.60	1.83	1.27	0.85
3.80 l/s	228 l/min	R	16287.59	5289.02	1649.23	481.40	155.40	50.51	16.45	7.04	2.91	1.10
		v	43.06	27.77	17.56	10.77	6.84	4.34	2.74	1.94	1.34	0.90
4.00 l/s	240 l/min	R	18008.27	5842.81	1819.97	530.56	171.07	55.54	18.07	7.73	3.19	1.21
		v	45.33	29.23	18.48	11.33	7.20	4.57	2.89	2.04	1.41	0.95
4.20 l/s	252 l/min	R	19814.99	6423.96	1998.99	582.05	187.46	60.80	19.77	8.45	3.49	1.32
		v	47.59	30.69	19.41	11.90	7.56	4.79	3.03	2.14	1.49	0.99
4.40 l/s	264 l/min	R	21707.77	7032.46	2186.30	635.88	204.57	66.28	21.53	9.20	3.80	1.43
		v	49.86	32.15	20.33	12.46	7.92	5.02	3.18	2.24	1.56	1.04
4.60 l/s	276 l/min	R	23686.58	7668.31	2381.89	692.02	222.41	71.99	23.36	9.98	4.12	1.55
		v	52.13	33.61	21.25	13.03	8.28	5.25	3.32	2.34	1.63	1.09

\dot{V} = Volumetric current [l/s] R = Pressure gradient [mbar/m] v = Flow rate [m/s]

Pipe friction factor R and calculated flow rate v in dependence on the volumetric current \dot{V}

fusiotherm®-pipe SDR 6

Temperature: 20 °C

Roughness: 0.0070 mm

Density: 998.2 kg/m³

Viscosity: 1.004 x 10⁻⁶ m²/s

\dot{V}		Di- men- sion	16.0 mm	20.0 mm	25.0 mm	32.0 mm	40.0 mm	50.0 mm	63.0 mm	75.0 mm	90.0 mm	110.0 mm
4.80 l/s	288 l/min	R	25751.44	8331.50	2585.76	750.49	240.96	77.92	25.27	10.78	4.45	1.68
		v	54.39	35.08	22.18	13.60	8.64	5.48	3.46	2.44	1.70	1.13
5.00 l/s	300 l/min	R		9022.03	2797.90	811.28	260.24	84.08	27.24	11.62	4.79	1.81
		v		36.54	23.10	14.16	9.00	5.71	3.61	2.55	1.77	1.18
5.20 l/s	312 l/min	R		9739.91	3018.31	874.39	280.23	90.46	29.28	12.49	5.14	1.94
		v		38.00	24.03	14.73	9.36	5.94	3.75	2.65	1.84	1.23
5.40 l/s	324 l/min	R		10485.12	3247.00	939.82	300.94	97.06	31.40	13.38	5.51	2.07
		v		39.46	24.95	15.30	9.72	6.16	3.90	2.75	1.91	1.28
5.60 l/s	336 l/min	R		11257.66	3483.96	1007.57	322.36	103.89	33.58	14.30	5.89	2.22
		v		40.92	25.88	15.86	10.08	6.39	4.04	2.85	1.98	1.32
5.80 l/s	348 l/min	R		12057.54	3729.18	1077.64	344.50	110.94	35.83	15.25	6.28	2.36
		v		42.38	26.80	16.43	10.44	6.62	4.19	2.95	2.05	1.37
6.00 l/s	360 l/min	R		12884.75	3982.67	1150.02	367.36	118.21	38.15	16.23	6.68	2.51
		v		43.84	27.72	17.00	10.80	6.85	4.33	3.06	2.12	1.42
6.20 l/s	372 l/min	R		13739.29	4244.43	1224.72	390.93	125.70	40.54	17.24	7.09	2.66
		v		45.31	28.65	17.56	11.16	7.08	4.48	3.16	2.19	1.47
6.40 l/s	384 l/min	R		14621.17	4514.45	1301.73	415.22	133.41	43.00	18.28	7.51	2.82
		v		46.77	29.57	18.13	11.52	7.30	4.62	3.26	2.26	1.51
6.60 l/s	396 l/min	R		15530.37	4792.74	1381.05	440.22	141.35	45.53	19.35	7.95	2.99
		v		48.23	30.50	18.70	11.88	7.53	4.76	3.36	2.33	1.56
6.80 l/s	408 l/min	R		16466.89	5079.29	1462.69	465.93	149.50	48.12	20.44	8.39	3.15
		v		49.69	31.42	19.26	12.24	7.76	4.91	3.46	2.41	1.61
7.00 l/s	420 l/min	R		17430.75	5374.10	1546.64	492.36	157.88	50.79	21.56	8.85	3.32
		v		51.15	32.34	19.83	12.60	7.99	5.05	3.57	2.48	1.65
7.50 l/s	450 l/min	R		19959.93	6147.28	1766.63	561.54	179.78	57.75	24.49	10.04	3.77
		v		54.81	34.65	21.25	13.50	8.56	5.41	3.82	2.65	1.77
8.00 l/s	480 l/min	R		22659.89	6972.08	2001.06	635.17	203.05	65.13	27.60	11.31	4.24
		v		58.46	36.96	22.66	14.40	9.13	5.77	4.07	2.83	1.89
9.00 l/s	540 l/min	R		28572.11	8776.52	2513.23	795.77	253.72	81.18	34.33	14.04	5.25
		v		65.77	41.59	25.50	16.20	10.27	6.50	4.58	3.18	2.13
10.0 l/s	600 l/min	R			10787.40	3083.09	974.11	309.86	98.90	41.76	17.05	6.37
		v			46.21	28.33	17.99	11.41	7.22	5.09	3.54	2.36
12.0 l/s	720 l/min	R			15428.32	4395.84	1383.98	438.49	139.40	58.69	23.89	8.90
		v			55.45	34.00	21.59	13.70	8.66	6.11	4.24	2.84
14.0 l/s	840 l/min	R			20894.66	5939.17	1864.66	588.89	186.56	78.35	31.82	11.83
		v			64.69	39.66	25.19	15.98	10.11	7.13	4.95	3.31
16.0 l/s	960 l/min	R				7712.99	2416.10	760.99	240.38	100.73	40.82	15.14
		v				45.33	28.79	18.26	11.55	8.15	5.66	3.78
18.0 l/s	1080 l/min	R				9717.25	3038.24	954.77	300.83	125.81	50.88	18.84
		v				50.99	32.39	20.54	12.99	9.17	6.37	4.25

\dot{V} = Volumetric current [l/s]

R = Pressure gradient [mbar/m]

v = Flow rate [m/s]

Pipe friction factor R and calculated flow rate v in dependence on the volumetric current \dot{V}

fusiotherm®-pipe SDR 6

Temperature: 20 °C

Roughness: 0.0070 mm Density: 998.2 kg/m³ Viscosity: 1.004 x 10⁻⁶ m²/s

\dot{V}		Di- men- sion	16.0 mm	20.0 mm	25.0 mm	32.0 mm	40.0 mm	50.0 mm	63.0 mm	75.0 mm	90.0 mm	110.0 mm
20.0 l/s	1200 l/min	R				11951.91	3731.06	1170.21	367.89	153.59	62.01	22.91
	v	v				56.66	35.99	22.83	14.44	10.19	7.07	4.73
22.0 l/s	1320 l/min	R				14416.97	4494.54	1407.28	441.56	184.05	74.19	27.37
	v	v				62.32	39.59	25.11	15.88	11.20	7.78	5.20
24.0 l/s	1440 l/min	R				17112.39	5328.65	1665.98	521.81	217.19	87.41	32.19
	v	v				67.99	43.19	27.39	17.32	12.22	8.49	5.67
26.0 l/s	1560 l/min	R					6233.40	1946.30	608.66	253.01	101.69	37.40
	v	v					46.79	29.68	18.77	13.24	9.20	6.14
28.0 l/s	1680 l/min	R					7208.77	2248.23	702.08	291.50	117.01	42.97
	v	v					50.39	31.96	20.21	14.26	9.90	6.62
30.0 l/s	1800 l/min	R					8254.76	2571.76	802.08	332.65	133.38	48.92
	v	v					53.98	34.24	21.65	15.28	10.61	7.09
32.0 l/s	1920 l/min	R					9371.36	2916.89	908.66	376.48	150.78	55.24
	v	v					57.58	36.52	23.01	16.30	11.32	7.56
34.0 l/s	2040 l/min	R					10558.56	3283.62	1021.81	422.96	169.23	61.93
	v	v					61.18	38.81	24.54	17.32	12.03	8.04
36.0 l/s	2160 l/min	R					11816.37	3671.94	1141.52	472.11	188.71	68.99
	v	v					64.78	41.09	25.98	18.33	12.73	8.51
38.0 l/s	2280 l/min	R						4081.85	1267.80	523.92	209.23	76.41
	v	v						43.37	27.43	19.35	13.44	8.98
40.0 l/s	2400 l/min	R						4513.35	1400.65	578.39	230.79	84.20
	v	v						45.65	28.87	20.37	14.15	9.45
42.0 l/s	2520 l/min	R						4966.44	1540.06	635.51	253.38	92.36
	v	v						47.94	30.32	21.39	14.85	9.93
44.0 l/s	2640 l/min	R						5441.11	1686.03	695.29	277.00	100.89
	v	v						50.22	31.76	22.41	15.56	10.40
46.0 l/s	2760 l/min	R						5937.36	1838.56	757.73	301.66	109.78
	v	v						52.50	33.20	23.43	16.27	10.87
48.0 l/s	2880 l/min	R						6455.20	1997.65	822.82	327.35	119.03
	v	v						54.78	34.65	24.45	16.98	11.34
50.0 l/s	3000 l/min	R						6994.62	2163.29	890.56	354.08	128.65
	v	v						57.07	36.09	25.46	17.68	11.82
52.0 l/s	3120 l/min	R						7555.63	2335.50	960.96	381.84	138.64
	v	v						59.35	37.53	26.48	18.39	12.29
54.0 l/s	3240 l/min	R						8138.21	2514.27	1034.01	410.63	148.99
	v	v						61.63	38.98	27.50	19.01	12.76
56.0 l/s	3360 l/min	R						8742.37	2699.59	1109.71	440.45	159.71
	v	v						63.92	40.42	28.52	19.81	13.23
58.0 l/s	3480 l/min	R						9368.11	2891.46	1188.06	471.30	170.79
	v	v						66.20	41.86	29.54	20.51	13.71

\dot{V} = Volumetric current [l/s] R = Pressure gradient [mbar/m] v = Flow rate [m/s]

Pipe friction factor R and calculated flow rate v in dependence on the volumetric current \dot{V}

fusiotherm®-pipe SDR 6

Temperature: 20 °C

Roughness: 0.0070 mm Density: 998.2 kg/m³ Viscosity: 1.004 x 10⁻⁶ m²/s

\dot{V}		Di- men- sion	16.0 mm	20.0 mm	25.0 mm	32.0 mm	40.0 mm	50.0 mm	63.0 mm	75.0 mm	90.0 mm	110.0 mm
60.0 l/s	3600 l/min	R							3089.90	1269.07	503.18	182.23
	v								43.31	30.56	21.22	14.18
62.0 l/s	3720 l/min	R							3294.89	1352.72	536.09	194.04
	v								44.75	31.58	21.93	14.65
64.0 l/s	3840 l/min	R							3506.43	1439.03	570.04	206.21
	v								46.19	32.59	22.64	15.13
66.0 l/s	3960 l/min	R							3724.53	1527.99	605.01	218.74
	v								47.64	33.61	23.34	15.60
68.0 l/s	4080 l/min	R							3949.18	1619.59	641.01	231.64
	v								49.08	34.63	24.05	16.07
70.0 l/s	4200 l/min	R							4180.39	1713.85	678.05	244.89
	v								50.53	35.65	24.76	16.54
72.0 l/s	4320 l/min	R							4418.16	1810.76	716.11	258.52
	v								51.97	36.67	25.46	17.02
74.0 l/s	4440 l/min	R							4662.47	1910.31	755.20	272.50
	v								53.41	37.69	26.17	17.49
76.0 l/s	4560 l/min	R							4913.34	2012.52	795.32	286.85
	v								54.86	38.71	26.88	17.96
78.0 l/s	4680 l/min	R							5170.76	2117.38	836.47	301.56
	v								56.30	39.73	27.59	18.43

\dot{V} = Volumetric current [l/s]

R = Pressure gradient [mbar/m]

v = Flow rate [m/s]

Pipe friction factor R and calculated flow rate v in dependence on the volumetric current \dot{V}

fusiotherm®-faser composite pipe SDR 7.4 - fusiotherm®-stabi composite pipe SDR 7.4
Temperature: 20 °C

Roughness: 0.0070 mm Density: 998.2 kg/m³ Viscosity: 1.004 x 10⁻⁶ m²/s

\dot{V}		Di- men- sion	16.0 mm	20.0 mm	25.0 mm	32.0 mm	40.0 mm	50.0 mm	63.0 mm	75.0 mm	90.0 mm	110.0 mm	125.0 mm	160.0 mm	200.0 mm	250.0 mm		
0.01 l/s	0.60 l/min	R	0.24	0.09	0.03	0.01	0.00	0.00	0.00	0.00	0.00	0.00	0.00	0.00	0.00	0.00	0.00	
		v	0.09	0.06	0.04	0.02	0.02	0.00	0.01	0.00	0.00	0.00	0.00	0.00	0.00	0.00	0.00	0.00
0.02 l/s	1.20 l/min	R	0.75	0.27	0.01	0.03	0.01	0.00	0.00	0.00	0.00	0.00	0.00	0.00	0.00	0.00	0.00	0.00
		v	0.19	0.12	0.08	0.05	0.03	0.02	0.01	0.01	0.01	0.00	0.00	0.00	0.00	0.00	0.00	0.00
0.03 l/s	1.80 l/min	R	1.49	0.54	0.19	0.06	0.02	0.01	0.00	0.00	0.00	0.00	0.00	0.00	0.00	0.00	0.00	0.00
		v	0.28	0.18	0.12	0.07	0.05	0.03	0.02	0.01	0.01	0.01	0.01	0.01	0.00	0.00	0.00	0.00
0.04 l/s	2.40 l/min	R	2.43	0.88	0.31	0.09	0.03	0.01	0.00	0.00	0.00	0.00	0.00	0.00	0.00	0.00	0.00	0.00
		v	0.38	0.25	0.16	0.09	0.06	0.04	0.02	0.02	0.01	0.01	0.01	0.01	0.00	0.00	0.00	0.00
0.05 l/s	3.00 l/min	R	3.58	1.28	0.45	0.14	0.05	0.02	0.01	0.00	0.00	0.00	0.00	0.00	0.00	0.00	0.00	0.00
		v	0.47	0.31	0.20	0.12	0.08	0.05	0.03	0.02	0.01	0.01	0.01	0.01	0.01	0.01	0.00	0.00
0.06 l/s	3.60 l/min	R	4.91	1.76	0.61	0.18	0.06	0.02	0.01	0.00	0.00	0.00	0.00	0.00	0.00	0.00	0.00	0.00
		v	0.57	0.37	0.24	0.14	0.09	0.06	0.04	0.03	0.02	0.01	0.01	0.01	0.01	0.01	0.00	0.00
0.07 l/s	4.20 l/min	R	6.42	2.29	0.80	0.24	0.08	0.03	0.00	0.00	0.00	0.00	0.00	0.00	0.00	0.00	0.00	0.00
		v	0.66	0.43	0.28	0.17	0.11	0.07	0.04	0.03	0.02	0.01	0.01	0.01	0.01	0.01	0.00	0.00
0.08 l/s	4.80 l/min	R	8.10	2.89	1.00	0.30	0.11	0.04	0.01	0.01	0.00	0.00	0.00	0.00	0.00	0.00	0.00	0.00
		v	0.76	0.49	0.31	0.19	0.12	0.08	0.05	0.03	0.02	0.02	0.01	0.01	0.01	0.01	0.01	0.00
0.09 l/s	5.40 l/min	R	9.96	3.55	1.23	0.37	0.13	0.05	0.02	0.01	0.00	0.00	0.00	0.00	0.00	0.00	0.00	0.00
		v	0.85	0.55	0.35	0.21	0.14	0.09	0.05	0.04	0.03	0.02	0.01	0.01	0.01	0.01	0.01	0.00
0.10 l/s	6.00 l/min	R	11.99	4.27	1.48	0.44	0.15	0.05	0.02	0.01	0.00	0.00	0.00	0.00	0.00	0.00	0.00	0.00
		v	0.95	0.61	0.39	0.24	0.15	0.01	0.06	0.04	0.03	0.02	0.02	0.02	0.01	0.01	0.01	0.00
0.12 l/s	7.20 l/min	R	16.54	5.87	2.03	0.61	0.21	0.07	0.02	0.01	0.01	0.00	0.00	0.00	0.00	0.00	0.00	0.00
		v	1.14	0.74	0.47	0.28	0.18	0.12	0.07	0.05	0.04	0.02	0.02	0.02	0.01	0.01	0.01	0.01
0.16 l/s	9.60 l/min	R	27.56	9.74	3.35	1.00	0.35	0.12	0.04	0.02	0.01	0.00	0.00	0.00	0.00	0.00	0.00	0.00
		v	1.51	0.98	0.63	0.38	0.24	0.16	0.01	0.07	0.05	0.03	0.02	0.02	0.02	0.00	0.00	0.01
0.18 l/s	10.8 l/min	R	34.01	12.00	4.12	1.23	0.43	0.15	0.05	0.02	0.01	0.00	0.00	0.00	0.00	0.00	0.00	0.00
		v	1.70	1.11	0.71	0.43	0.27	0.17	0.11	0.08	0.05	0.04	0.03	0.02	0.02	0.01	0.01	0.01
0.20 l/s	12.0 l/min	R	41.07	14.47	4.96	1.48	0.51	0.18	0.06	0.03	0.01	0.00	0.00	0.00	0.00	0.00	0.00	0.00
		v	1.89	1.23	0.79	0.47	0.30	0.19	0.12	0.09	0.06	0.04	0.03	0.02	0.02	0.01	0.01	0.01
0.30 l/s	18.0 l/min	R	85.35	29.85	10.17	3.01	1.04	0.36	0.12	0.05	0.02	0.01	0.01	0.00	0.00	0.00	0.00	0.00
		v	2.84	1.84	1.18	0.71	0.45	0.29	0.18	0.13	0.09	0.06	0.05	0.03	0.03	0.02	0.02	0.01
0.40 l/s	24.0 l/min	R	144.17	50.15	17.00	5.01	1.72	0.60	0.19	0.09	0.04	0.01	0.01	0.00	0.00	0.00	0.00	0.00
		v	3.78	2.46	1.57	0.95	0.61	0.39	0.24	0.17	0.12	0.08	0.06	0.04	0.04	0.02	0.02	0.02
0.50 l/s	30.0 l/min	R	217.21	75.21	25.40	7.45	2.55	0.88	0.29	0.13	0.05	0.02	0.01	0.00	0.00	0.00	0.00	0.00
		v	4.73	3.07	1.96	1.18	0.76	0.49	0.30	0.22	0.15	0.10	0.08	0.05	0.05	0.03	0.02	0.02
0.60 l/s	36.0 l/min	R	304.25	104.94	35.31	10.33	3.53	1.22	0.40	0.17	0.07	0.03	0.02	0.01	0.00	0.00	0.00	0.00
		v	5.68	3.68	2.36	1.42	0.91	0.58	0.36	0.26	0.18	0.12	0.09	0.06	0.06	0.04	0.02	0.02
0.70 l/s	42.0 l/min	R	405.16	139.27	46.72	13.62	4.64	1.60	0.52	0.23	0.01	0.04	0.02	0.01	0.00	0.00	0.00	0.00
		v	6.62	4.30	2.75	1.66	1.06	0.68	0.42	0.30	0.21	0.14	0.11	0.07	0.07	0.04	0.04	0.03

\dot{V} = Volumetric current [l/s] R = Pressure gradient [mbar/m] v = Flow rate [m/s]

Pipe friction factor R and calculated flow rate \dot{V}

fusiotherm®-faser composite pipe SDR 7.4 - fusiotherm®-stabi composite pipe SDR 7.4

Temperature: 20 °C

Roughness: 0.0070 mm Density: 998.2 kg/m³ Viscosity: 1.004 x 10⁻⁶ m²/s

\dot{V}		Di- men- sion	16.0 mm	20.0 mm	25.0 mm	32.0 mm	40.0 mm	50.0 mm	63.0 mm	75.0 mm	90.0 mm	110.0 mm	125.0 mm	160.0 mm	200.0 mm	250.0 mm
0.80 l/s	48.0 l/min	R	519.85	178.15	59.60	17.33	5.90	2.03	0.66	0.29	0.12	0.05	0.03	0.01	0.00	0.00
	v		7.57	4.91	3.14	1.89	1.21	0.78	0.49	0.34	0.24	0.16	0.12	0.08	0.05	0.03
0.90 l/s	54.0 l/min	R	648.25	221.55	73.92	21.45	7.28	2.50	0.81	0.36	0.15	0.06	0.03	0.00	0.00	0.00
	v		8.52	5.53	3.54	2.13	1.36	0.87	0.55	0.39	0.27	0.18	0.14	0.08	0.05	0.04
1.00 l/s	60.0 l/min	R	790.30	269.43	89.69	25.97	8.80	3.02	0.98	0.43	0.18	0.07	0.04	0.01	0.00	0.00
	v		9.46	6.14	3.93	2.37	1.51	0.97	0.61	0.43	0.30	0.20	0.15	0.09	0.06	0.04
1.20 l/s	72.0 l/min	R	1115.23	378.58	125.51	36.19	12.23	4.19	1.35	0.59	0.25	0.09	0.05	0.02	0.01	0.00
	v		11.35	7.37	4.72	2.84	1.82	1.17	0.73	0.52	0.36	0.24	0.19	0.11	0.07	0.05
1.40 l/s	84.0 l/min	R	1494.40	505.47	166.98	47.97	16.17	5.52	1.78	0.78	0.32	0.12	0.07	0.02	0.01	0.00
	v		13.25	8.60	5.50	3.31	2.12	1.36	0.85	0.60	0.42	0.28	0.22	0.13	0.08	0.05
1.60 l/s	96.0 l/min	R	1927.68	650.00	214.05	61.29	20.61	7.03	2.26	0.99	0.41	0.16	0.09	0.03	0.01	0.00
	v		15.14	9.82	6.29	3.78	2.42	1.55	0.97	0.69	0.48	0.32	0.25	0.15	0.01	0.06
1.80 l/s	108 l/min	R	2414.97	812.11	266.69	76.14	25.55	8.69	2.79	1.22	0.50	0.19	0.10	0.03	0.01	0.00
	v		17.03	11.05	7.07	4.26	2.73	1.75	1.09	0.77	0.54	0.36	0.28	0.17	0.11	0.07
2.00 l/s	120 l/min	R	2956.18	991.77	324.88	92.51	30.97	10.52	3.37	1.47	0.61	0.23	0.13	0.04	0.01	0.01
	v		18.92	12.28	7.86	4.73	3.03	1.94	1.21	0.86	0.60	0.40	0.31	0.19	0.12	0.08
2.20 l/s	132 l/min	R	3551.28	1188.92	388.58	110.38	36.89	12.51	4.00	1.75	0.72	0.28	0.15	0.05	0.02	0.01
	v		20.82	13.51	8.65	5.20	3.33	2.14	1.34	0.95	0.65	0.44	0.34	0.21	0.13	0.09
2.40 l/s	144 l/min	R	4200.22	1403.55	457.79	129.75	43.28	14.66	4.68	2.04	0.84	0.32	0.17	0.05	0.02	0.01
	v		22.71	14.74	9.43	5.68	3.63	2.33	1.46	1.03	0.71	0.48	0.37	0.23	0.14	0.09
2.60 l/s	156 l/min	R	4902.97	1635.62	532.49	150.61	50.15	16.96	5.41	2.36	0.97	0.37	0.20	0.06	0.02	0.01
	v		24.60	15.96	10.22	6.15	3.94	2.53	1.58	1.12	0.77	0.52	0.40	0.25	0.16	0.10
2.80 l/s	168 l/min	R	5659.51	1885.14	612.68	172.95	57.51	19.42	6.19	2.69	1.11	0.43	0.23	0.07	0.02	0.01
	v		26.49	17.19	11.00	6.62	4.24	2.72	1.70	1.20	0.83	0.56	0.43	0.26	0.17	0.11
3.00 l/s	180 l/min	R	6469.83	2152.07	698.33	196.77	65.33	22.04	7.02	3.05	1.25	0.48	0.26	0.08	0.03	0.00
	v		28.39	18.42	11.79	7.01	4.54	2.91	1.82	1.29	0.89	0.60	0.46	0.28	0.18	0.12
3.20 l/s	192 l/min	R	7333.90	2436.42	789.45	222.07	73.63	24.81	7.89	3.43	1.41	0.54	0.29	0.09	0.03	0.01
	v		30.28	19.65	12.58	7.57	4.84	3.11	1.94	1.38	0.95	0.64	0.49	0.30	0.19	0.13
3.40 l/s	204 l/min	R	8251.71	2738.16	886.03	248.84	82.39	27.73	8.81	3.82	1.57	0.60	0.32	0.01	0.03	0.01
	v		32.17	20.88	13.36	8.04	5.15	3.30	2.06	1.46	1.01	0.68	0.53	0.32	0.21	0.13
3.60 l/s	216 l/min	R	9223.26	3057.30	988.06	277.08	91.63	30.80	9.78	4.24	1.74	0.67	0.36	0.11	0.04	0.01
	v		34.06	22.10	14.15	8.52	5.45	3.50	2.19	1.55	1.07	0.72	0.56	0.34	0.22	0.14
3.80 l/s	228 l/min	R	10248.54	3393.82	1095.53	306.79	101.33	34.02	10.79	4.68	1.92	0.74	0.40	0.12	0.04	0.01
	v		35.96	23.33	14.93	8.99	5.75	3.69	2.31	1.63	1.13	0.76	0.59	0.36	0.23	0.15
4.00 l/s	240 l/min	R	11327.55	3747.73	1208.45	337.96	111.50	37.40	11.85	5.13	2.11	0.81	0.43	0.13	0.05	0.02
	v		37.85	24.56	15.72	9.46	6.06	3.89	2.43	1.72	1.19	0.80	0.62	0.38	0.24	0.16
4.20 l/s	252 l/min	R	12460.26	4119.01	1326.81	370.59	122.13	40.93	12.95	5.61	2.30	0.88	0.47	0.14	0.05	0.02
	v		39.74	25.79	16.50	9.94	6.36	4.08	2.55	1.81	1.25	0.84	0.65	0.40	0.25	0.16

\dot{V} = Volumetric current [l/s]

R = Pressure gradient [mbar/m]

v = Flow rate [m/s]

Pipe friction factor R and calculated flow rate v in dependence on the volumetric current V̇

fusiotherm®-faser composite pipe SDR 7.4 - fusiotherm®-stabi composite pipe SDR 7.4

Temperature: 20 °C

Roughness: 0.0070 mm Density: 998.2 kg/m³ Viscosity: 1.004 x 10⁻⁶ m²/s

V̇		Di- men- sion	16.0 mm	20.0 mm	25.0 mm	32.0 mm	40.0 mm	50.0 mm	63.0 mm	75.0 mm	90.0 mm	110.0 mm	125.0 mm	160.0 mm	200.0 mm	250.0 mm
4.40 l/s	264 l/min	R	13646.69	4507.66	1450.61	404.68	133.23	44.60	14.10	6.11	2.50	0.96	0.51	0.16	0.05	0.02
	v		41.63	27.02	17.29	10.41	6.66	4.28	2.67	1.89	1.31	0.88	0.68	0.41	0.27	0.17
4.60 l/s	276 l/min	R	14886.82	4913.68	1579.84	440.23	144.79	48.43	15.30	6.62	2.71	1.04	0.56	0.17	0.06	0.02
	v		43.53	28.25	18.08	10.88	6.96	4.47	2.79	1.98	1.37	0.92	0.71	0.43	0.28	0.18
4.80 l/s	288 l/min	R	16180.66	5337.07	1714.51	477.24	156.81	52.40	16.54	7.15	2.93	1.12	0.60	0.18	0.06	0.02
	v		45.42	29.47	18.86	11.35	7.27	4.66	2.91	2.07	1.43	0.96	0.74	0.45	0.29	0.19
5.00 l/s	300 l/min	R		5777.81	1854.60	515.71	169.29	56.53	17.83	7.71	3.15	1.21	0.65	0.20	0.07	0.02
	v			30.70	19.65	11.83	7.57	4.86	3.03	2.15	1.49	1.00	0.77	0.47	0.30	0.20
5.20 l/s	312 l/min	R		6235.92	2000.12	555.63	182.23	60.80	19.16	8.28	3.39	1.29	0.69	0.21	0.07	0.03
	v			31.93	20.43	12.30	7.87	5.05	3.16	2.24	1.55	1.04	0.80	0.49	0.31	0.20
5.40 l/s	324 l/min	R		6711.39	2151.07	597.00	195.64	65.22	20.54	8.87	3.63	1.39	0.74	0.23	0.08	0.03
	v			33.16	21.22	12.77	8.18	5.25	3.28	2.32	1.61	1.08	0.83	0.51	0.33	0.21
5.60 l/s	336 l/min	R		7204.21	2307.44	639.83	209.50	69.78	21.96	9.48	3.87	1.48	0.79	0.24	0.08	0.03
	v			34.39	22.01	13.25	8.48	5.44	3.40	2.41	1.67	1.12	0.86	0.53	0.34	0.22
5.80 l/s	348 l/min	R		7714.39	2469.24	684.11	223.82	74.50	23.43	10.11	4.13	1.58	0.85	0.26	0.09	0.03
	v			35.61	22.79	13.72	8.78	5.64	3.52	2.50	1.73	1.16	0.90	0.55	0.35	0.23
6.00 l/s	360 l/min	R		8241.92	2636.46	729.84	238.60	79.36	24.94	10.76	4.39	1.68	0.90	0.27	0.09	0.03
	v			36.84	23.58	14.19	9.08	5.83	3.64	2.58	1.79	1.20	0.93	0.57	0.36	0.23
6.20 l/s	372 l/min	R		8786.80	2809.10	777.02	253.84	84.37	26.50	11.42	4.66	1.78	0.95	0.29	0.10	0.04
	v			38.07	24.36	14.67	9.39	6.02	3.76	2.67	1.85	1.24	0.96	0.58	0.37	0.24
6.40 l/s	384 l/min	R		9349.04	2987.16	825.65	269.53	89.52	28.01	12.11	4.94	1.88	1.01	0.31	0.11	0.04
	v			39.30	25.15	15.14	9.69	6.22	3.88	2.75	1.91	1.28	0.99	0.60	0.39	0.25
6.60 l/s	396 l/min	R		9928.62	3170.64	875.73	285.68	94.82	29.74	12.81	5.23	1.99	1.07	0.33	0.11	0.04
	v			40.53	25.94	15.61	9.99	6.41	4.01	2.84	1.96	1.32	1.02	0.62	0.40	0.26
6.80 l/s	408 l/min	R		10525.55	3359.54	927.25	302.29	100.27	31.43	13.53	5.52	2.10	1.13	0.34	0.12	0.04
	v			41.75	26.72	16.09	10.29	6.61	4.13	2.93	2.02	1.36	1.05	0.64	0.41	0.27
7.00 l/s	420 l/min	R		11139.83	3553.86	980.23	319.36	105.86	33.16	14.27	5.82	2.22	1.19	0.36	0.12	0.04
	v			42.98	27.51	16.56	10.60	6.80	4.25	3.01	2.08	1.40	1.08	0.66	0.42	0.27
7.50 l/s	450 l/min	R		12751.43	4063.35	1119.00	364.01	120.49	37.69	16.21	6.60	2.51	1.34	0.41	0.14	0.05
	v			46.05	29.47	17.74	11.35	7.29	4.55	3.23	2.23	1.50	1.16	0.71	0.45	0.29
8.00 l/s	480 l/min	R		14471.43	4606.69	1266.81	411.52	136.02	42.49	18.25	7.43	2.82	1.51	0.46	0.16	0.06
	v			49.12	31.44	18.92	12.11	7.77	4.86	3.44	2.38	1.60	1.24	0.75	0.48	0.31
9.00 l/s	540 l/min	R		18236.63	5794.90	1589.53	515.05	169.80	52.90	22.69	9.22	3.50	1.87	0.57	0.19	0.07
	v			55.26	35.37	21.29	13.63	8.74	5.46	3.87	2.68	1.80	1.39	0.85	0.54	0.35
10.0 l/s	600 l/min	R			7118.43	1948.35	629.93	207.19	64.40	27.58	11.19	4.24	2.27	0.69	0.24	0.08
	v				39.30	23.66	15.14	9.72	6.07	4.30	2.98	2.00	1.54	0.94	0.60	0.39
12.0 l/s	720 l/min	R			10171.36	2774.23	893.66	292.78	90.64	38.70	15.66	5.92	3.16	0.96	0.33	0.11
	v				47.16	28.39	18.17	11.66	7.28	5.16	3.57	2.40	1.85	1.13	0.72	0.47
14.0 l/s	840 l/min	R			13765.32	3744.31	1202.62	392.73	121.15	51.60	20.83	7.86	4.19	1.27	0.43	0.15
	v				55.02	33.12	21.20	13.60	8.50	6.02	4.17	2.80	2.16	1.32	0.85	0.55

V̇ = Volumetric current [l/s] R = Pressure gradient [mbar/m] v = Flow rate [m/s]

Pipe friction factor R and calculated flow rate v in dependence on the volumetric current \dot{V}

fusiotherm®-faser composite pipe SDR 7.4 - fusiotherm®-stabi composite pipe SDR 7.4

Temperature: 20 °C

Roughness: 0.0070 mm Density: 998.2 kg/m³ Viscosity: 1.004 x 10⁻⁶ m²/s

\dot{V}		Di- men- sion	16.0 mm	20.0 mm	25.0 mm	32.0 mm	40.0 mm	50.0 mm	63.0 mm	75.0 mm	90.0 mm	110.0 mm	125.0 mm	160.0 mm	200.0 mm	250.0 mm
16.0 l/s	960 l/min	R				4858.51	1556.75	506.99	155.92	66.27	26.69	10.05	5.35	1.61	0.55	0.19
	v	v				3785	24.22	15.55	9.71	6.88	4.76	3.20	2.47	1.51	0.97	0.63
18.0 l/s	1080 l/min	R				6116.78	1956.00	635.54	194.94	82.70	33.24	12.50	6.65	2.00	0.68	0.24
	v	v				42.58	27.25	17.49	10.93	7.74	5.36	3.60	2.78	1.70	1.09	0.70
20.0 l/s	1200 l/min	R				7519.10	2400.35	778.35	238.19	100.87	40.48	15.19	8.07	2.43	0.82	0.29
	v	v				4731	30.28	19.43	12.14	8.60	5.95	4.00	3.09	1.89	1.21	0.78
22.0 l/s	1320 l/min	R				9065.44	2889.78	935.41	285.66	120.79	48.39	18.13	9.62	2.89	0.98	0.34
	v	v				52.04	33.31	21.38	13.35	9.47	6.55	4.40	3.40	2.07	1.33	0.86
24.0 l/s	1440 l/min	R				10755.78	3424.28	1106.72	337.35	142.44	56.98	21.32	11.31	3.39	1.15	0.40
	v	v				56.77	36.34	23.32	14.57	10.33	7.14	4.80	3.71	2.26	1.45	0.94
26.0 l/s	1560 l/min	R					4003.83	1292.25	393.24	165.83	66.25	24.75	13.11	3.92	1.33	0.46
	v	v					39.36	25.26	15.78	11.19	7.74	5.20	4.02	2.45	1.57	1.02
28.0 l/s	1680 l/min	R					4628.43	1492.01	453.33	190.94	76.18	28.43	15.05	4.50	1.52	0.53
	v	v					42.39	27.21	17.00	12.05	8.34	5.60	4.32	2.64	1.69	1.01
30.0 l/s	1800 l/min	R					5298.07	1705.99	517.63	217.78	86.79	32.35	17.11	5.11	1.73	0.60
	v	v					45.42	29.15	18.21	12.91	8.93	6.00	4.63	2.83	1.81	1.17
32.0 l/s	1920 l/min	R					6012.75	1934.18	586.12	246.35	98.06	36.51	19.30	5.75	1.94	0.68
	v	v					48.45	31.09	19.42	13.77	9.53	6.40	4.94	3.02	1.93	1.25
34.0 l/s	2040 l/min	R					6772.46	2176.59	658.81	276.64	110.00	40.91	21.61	6.44	2.17	0.76
	v	v					51.47	33.03	20.64	14.63	10.12	6.80	5.25	3.21	2.05	1.33
36.0 l/s	2160 l/min	R					7577.20	2433.21	735.69	308.65	122.61	45.55	24.05	7.15	2.41	0.84
	v	v					54.50	34.98	21.85	15.49	10.72	7.20	5.56	3.39	2.17	1.41
38.0 l/s	2280 l/min	R						2704.03	816.76	342.38	135.89	50.43	26.61	7.91	2.66	0.93
	v	v						36.92	23.07	16.35	11.31	7.60	5.87	3.58	2.29	1.49
40.0 l/s	2400 l/min	R						2989.06	902.01	377.83	149.83	55.55	29.30	8.70	2.93	1.02
	v	v						38.86	24.28	17.21	11.91	8.00	6.18	3.77	2.42	1.56
42.0 l/s	2520 l/min	R						3288.29	991.46	414.99	164.43	60.91	32.11	9.52	3.20	1.11
	v	v						40.81	25.49	18.07	12.50	8.40	6.49	3.96	2.54	1.64
44.0 l/s	2640 l/min	R						3601.72	1085.09	453.87	179.69	66.51	35.04	10.38	3.49	1.21
	v	v						42.75	26.71	18.93	13.01	8.80	6.80	4.15	2.66	1.72
46.0 l/s	2760 l/min	R						3929.35	1182.90	494.47	195.62	72.35	38.09	11.28	3.79	1.31
	v	v						44.69	27.92	19.79	13.69	9.20	7.10	4.34	2.78	1.80
48.0 l/s	2880 l/min	R						4271.18	1284.90	536.78	212.21	78.43	41.27	12.21	4.01	1.42
	v	v						46.64	29.14	20.65	14.29	9.60	7.41	4.53	2.90	1.88
50.0 l/s	3000 l/min	R						4627.22	1391.08	580.81	229.47	84.74	44.57	13.17	4.42	1.53
	v	v						48.58	30.35	21.51	14.88	10.00	7.72	4.71	3.02	1.96
52.0 l/s	3120 l/min	R						4997.44	1501.45	626.55	247.38	91.29	48.00	14.18	4.75	1.65
	v	v						50.52	31.56	22.37	15.48	10.40	8.03	4.90	3.14	2.03
54.0 l/s	3240 l/min	R						5381.87	1616.00	674.00	265.95	98.08	51.54	15.21	5.09	1.77
	v	v						52.47	32.78	23.23	16.07	10.80	8.34	5.09	3.26	2.11

\dot{V} = Volumetric current [l/s]

R = Pressure gradient [mbar/m]

v = Flow rate [m/s]

Pipe friction factor R and calculated flow rate v in dependence on the volumetric current \dot{V}

fusiotherm®-faser composite pipe SDR 7.4 - fusiotherm®-stabi composite pipe SDR 7.4
 Temperature: 20 °C

Roughness: 0.0070 mm Density: 998.2 kg/m³ Viscosity: 1.004 x 10⁻⁶ m²/s

\dot{V}		Di- men- sion	16.0 mm	20.0 mm	25.0 mm	32.0 mm	40.0 mm	50.0 mm	63.0 mm	75.0 mm	90.0 mm	110.0 mm	125.0 mm	160.0 mm	200.0 mm	250.0 mm
56.0 l/s	3360 l/min	R						5780.49	1734.73	723.17	285.19	105.10	55.21	16.28	5.45	1.89
	v	v						54.41	33.99	24.09	16.67	11.20	8.65	5.28	3.38	2.19
58.0 l/s	3480 l/min	R						6193.31	1857.64	774.05	305.08	112.36	59.00	17.39	5.81	2.01
	v	v						56.35	35.21	24.95	17.27	11.60	8.96	5.47	3.50	2.27
60.0 l/s	3600 l/min	R							1984.73	826.64	325.64	119.86	62.91	18.53	6.19	2.14
	v	v							36.42	25.81	17.86	12.00	9.27	5.66	3.62	2.35
62.0 l/s	3720 l/min	R							2116.00	880.94	346.85	127.59	66.95	19.70	6.58	2.28
	v	v							37.63	26.67	18.46	12.40	9.57	5.85	3.74	2.43
64.0 l/s	3840 l/min	R							2251.45	936.96	368.73	135.56	71.10	20.91	6.98	2.41
	v	v							38.85	27.54	19.05	12.80	9.88	6.04	3.87	2.50
66.0 l/s	3960 l/min	R							2391.08	994.68	391.26	143.77	75.38	22.15	7.39	2.55
	v	v							40.06	28.40	19.65	13.20	10.19	6.22	3.99	2.58
68.0 l/s	4080 l/min	R							2534.89	1054.12	414.46	152.21	79.78	23.43	7.81	2.70
	v	v							41.28	29.26	20.24	13.60	10.50	6.41	4.11	2.66
70.0 l/s	4200 l/min	R							2682.88	1115.27	438.31	160.89	84.30	24.74	8.25	2.85
	v	v							42.49	30.12	20.84	14.00	10.81	6.60	4.23	2.74
72.0 l/s	4320 l/min	R							2835.05	1178.12	462.82	169.80	88.94	26.09	8.69	3.00
	v	v							43.70	30.98	21.43	14.40	11.12	6.79	4.35	2.82
74.0 l/s	4440 l/min	R							2991.40	1242.69	487.99	178.95	93.70	27.47	9.15	3.16
	v	v							44.92	31.84	22.03	14.80	11.43	6.98	4.47	2.90
76.0 l/s	4560 l/min	R							3151.92	1308.97	513.82	188.34	98.59	28.88	9.62	3.32
	v	v							46.13	32.70	22.62	15.20	11.74	7.17	4.59	2.97
78.0 l/s	4680 l/min	R							3316.63	1376.96	540.31	197.96	103.59	30.33	10.09	3.48
	v	v							47.35	33.56	23.22	15.60	12.05	7.36	4.71	3.05
80.0 l/s	4800 l/min	R							3485.51	1446.66	567.45	207.81	108.72	31.81	10.58	3.65
	v	v							48.56	34.42	23.81	16.00	12.35	7.54	4.83	3.13
85.0 l/s	5100 l/min	R							3925.99	1628.38	638.19	233.48	122.06	35.67	11.85	4.08
	v	v							51.59	36.57	25.30	17.00	13.13	8.02	5.13	3.33
90.0 l/s	5400 l/min	R							4392.59	1820.79	713.05	260.62	136.16	39.74	13.19	4.54
	v	v							54.63	38.72	26.79	17.99	13.90	8.49	5.44	3.52
95.0 l/s	5700 l/min	R								2023.89	792.01	289.22	151.00	44.03	14.60	5.02
	v	v								40.87	28.28	18.99	14.67	8.96	5.74	3.72
100.0 l/s	6000 l/min	R								2237.66	875.09	319.29	166.62	48.52	16.07	5.52
	v	v								43.02	29.77	19.99	15.44	9.43	6.04	3.91
105.0 l/s	6300 l/min	R								2462.12	962.27	350.83	182.97	53.23	17.61	6.04
	v	v								45.18	31.26	20.99	16.22	9.90	6.34	4.11

\dot{V} = Volumetric current [l/ s] R = Pressure gradient [mbar/m] v = Flow rate [m/s]

Pipe friction factor R and calculated flow rate v in dependence on the volumetric current \dot{V}

fusiotherm®-pipe SDR 6

Temperature: 60 °C

Roughness: 0.0070 mm

Density: 983.20 kg/m³

Viscosity: 0.47 x 10⁻⁶ m²/s

\dot{V}		Di- men- sion	16.0 mm	20.0 mm	25.0 mm	32.0 mm	40.0 mm	50.0 mm	63.0 mm	75.0 mm	90.0 mm	110.0 mm
0.01 l/s	0.60 l/min	R	0.28	0.01	0.03	0.01	0.00	0.00	0.00	0.00	0.00	0.00
		v	0.11	0.07	0.05	0.03	0.02	0.01	0.01	0.01	0.00	0.00
0.02 l/s	1.20 l/min	R	0.90	0.32	0.11	0.03	0.01	0.00	0.00	0.00	0.00	0.00
		v	0.23	0.15	0.09	0.06	0.04	0.02	0.01	0.01	0.01	0.01
0.03 l/s	1.80 l/min	R	1.83	0.64	0.22	0.07	0.02	0.01	0.00	0.00	0.00	0.00
		v	0.34	0.22	0.14	0.08	0.05	0.03	0.02	0.02	0.01	0.01
0.04 l/s	2.40 l/min	R	3.03	1.06	0.36	0.11	0.04	0.01	0.00	0.00	0.00	0.00
		v	0.45	0.29	0.18	0.11	0.07	0.05	0.03	0.02	0.01	0.01
0.05 l/s	3.00 l/min	R	4.49	1.57	0.53	0.16	0.06	0.02	0.01	0.00	0.00	0.00
		v	0.57	0.37	0.23	0.14	0.09	0.06	0.04	0.03	0.02	0.01
0.06 l/s	3.60 l/min	R	6.20	2.16	0.72	0.23	0.08	0.03	0.01	0.00	0.00	0.00
		v	0.68	0.44	0.28	0.17	0.11	0.07	0.04	0.03	0.02	0.01
0.07 l/s	4.20 l/min	R	8.16	2.84	0.95	0.30	0.10	0.03	0.01	0.01	0.00	0.00
		v	0.79	0.51	0.32	0.20	0.13	0.08	0.05	0.04	0.02	0.02
0.08 l/s	4.80 l/min	R	10.36	3.60	1.20	0.37	0.13	0.04	0.01	0.01	0.00	0.00
		v	0.91	0.58	0.37	0.23	0.14	0.09	0.06	0.04	0.03	0.02
0.09 l/s	5.40 l/min	R	12.81	4.43	1.47	0.46	0.16	0.05	0.02	0.01	0.00	0.00
		v	1.02	0.66	0.42	0.25	0.16	0.10	0.06	0.05	0.03	0.02
0.10 l/s	6.00 l/min	R	15.48	5.35	1.78	0.55	0.19	0.06	0.02	0.01	0.00	0.00
		v	1.13	0.73	0.46	0.28	0.18	0.11	0.07	0.05	0.04	0.02
0.12 l/s	7.20 l/min	R	21.53	7.42	2.45	0.76	0.26	0.09	0.03	0.01	0.01	0.00
		v	1.36	0.88	0.55	0.34	0.22	0.14	0.09	0.06	0.04	0.03
0.16 l/s	9.60 l/min	R	36.36	12.46	4.10	1.26	0.43	0.14	0.05	0.02	0.01	0.00
		v	1.81	1.17	0.74	0.45	0.29	0.18	0.12	0.08	0.06	0.04
0.18 l/s	10.8 l/min	R	45.13	15.42	5.07	1.56	0.52	0.18	0.06	0.03	0.01	0.00
		v	2.04	1.32	0.83	0.51	0.32	0.21	0.13	0.09	0.06	0.04
0.20 l/s	12.0 l/min	R	54.78	18.68	6.12	1.88	0.63	0.21	0.07	0.03	0.01	0.01
		v	2.27	1.46	0.92	0.57	0.36	0.23	0.14	0.10	0.07	0.05
0.30 l/s	18.0 l/min	R	116.22	39.26	12.77	3.89	1.30	0.44	0.15	0.06	0.03	0.01
		v	3.40	2.19	1.39	0.85	0.54	0.34	0.22	0.15	0.11	0.07
0.40 l/s	24.0 l/min	R	199.34	66.87	21.61	6.54	2.18	0.73	0.24	0.11	0.04	0.02
		v	4.53	2.92	1.85	1.13	0.72	0.46	0.29	0.20	0.14	0.09
0.50 l/s	30.0 l/min	R	303.94	101.42	32.59	9.82	3.26	1.08	0.36	0.16	0.07	0.02
		v	5.67	3.65	2.31	1.42	0.90	0.57	0.36	0.25	0.18	0.12
0.60 l/s	36.0 l/min	R	429.93	142.83	45.70	13.71	4.53	1.50	0.50	0.22	0.09	0.03
		v	6.80	4.38	2.77	1.70	1.08	0.68	0.43	0.31	0.21	0.14
0.70 l/s	42.0 l/min	R	577.24	191.08	60.91	18.21	6.00	1.99	0.66	0.28	0.12	0.05
		v	7.93	5.12	3.23	1.98	1.26	0.80	0.51	0.36	0.25	0.17
0.80 l/s	48.0 l/min	R	745.84	246.13	78.20	23.30	7.66	2.53	0.83	0.36	0.15	0.06
		v	9.07	5.85	3.70	2.27	1.44	0.91	0.58	0.41	0.28	0.19

\dot{V} = Volumetric current [l/s]

R = Pressure gradient [mbar/m]

v = Flow rate [m/s]

Pipe friction factor R and calculated flow rate v in dependence on the volumetric current V̇

fusiotherm®-pipe SDR 6

Temperature: 60 °C

Roughness: 0.0070 mm Density: 983.20 kg/m³ Viscosity: 0.47 x 10⁻⁶ m²/s

V̇		Di- men- sion	16.0 mm	20.0 mm	25.0 mm	32.0 mm	40.0 mm	50.0 mm	63.0 mm	75.0 mm	90.0 mm	110.0 mm
0.90 l/s	54.0 l/min	R	935.69	307.97	97.57	28.98	9.50	3.13	1.03	0.44	0.19	0.07
		v	10.20	6.58	4.16	2.55	1.62	1.03	0.65	0.46	0.32	0.21
1.00 l/s	60.0 l/min	R	1146.78	376.59	119.00	35.25	11.53	3.79	1.25	0.54	0.22	0.08
		v	11.33	7.31	4.62	2.83	1.80	1.14	0.72	0.51	0.35	0.24
1.20 l/s	72.0 l/min	R	1632.64	534.11	168.05	49.55	16.14	5.29	1.74	0.75	0.31	0.12
		v	13.60	8.77	5.54	3.40	2.16	1.37	0.87	0.61	0.42	0.28
1.40 l/s	84.0 l/min	R	2203.34	718.65	225.31	66.18	21.48	7.02	2.30	0.99	0.41	0.15
		v	15.86	10.23	6.47	3.97	2.52	1.60	1.01	0.71	0.50	0.33
1.60 l/s	96.0 l/min	R	2858.84	930.18	290.76	85.11	27.55	8.98	2.93	1.26	0.52	0.20
		v	18.13	11.69	7.39	4.53	2.88	1.83	1.15	0.81	0.57	0.38
1.80 l/s	108 l/min	R	3599.12	1168.67	364.39	106.35	34.33	11.16	3.63	1.56	0.64	0.24
		v	20.40	13.15	8.32	5.01	3.24	2.05	1.30	0.92	0.64	0.43
2.00 l/s	120 l/min	R	4424.17	1434.11	446.18	129.89	41.82	13.56	4.41	1.88	0.78	0.29
		v	22.66	14.61	9.24	5.67	3.60	2.28	1.44	1.02	0.71	0.47
2.20 l/s	132 l/min	R	5333.97	1726.49	536.14	155.72	50.03	16.19	5.25	2.24	0.93	0.35
		v	24.93	16.08	10.17	6.23	3.96	2.51	1.59	1.12	0.78	0.52
2.40 l/s	144 l/min	R	6328.52	2045.80	634.24	183.83	58.95	19.04	6.17	2.63	1.08	0.41
		v	27.20	17.54	11.09	6.80	4.32	2.74	1.73	1.22	0.85	0.57
2.60 l/s	156 l/min	R	7407.80	2392.04	740.50	214.24	68.57	22.11	7.15	3.05	1.25	0.47
		v	29.46	19.00	12.01	7.37	4.68	2.97	1.88	1.32	0.92	0.61
2.80 l/s	168 l/min	R	8571.82	2765.20	854.90	246.92	78.90	25.39	8.20	3.49	1.43	0.54
		v	31.73	20.46	12.94	7.93	5.04	3.20	2.02	1.43	0.99	0.66
3.00 l/s	180 l/min	R	9820.57	3165.29	977.44	281.88	89.93	28.90	9.32	3.96	1.63	0.61
		v	34.00	21.92	13.86	8.50	5.40	3.42	2.17	1.53	1.06	0.71
3.20 l/s	192 l/min	R	11154.05	3592.29	1108.12	319.13	101.66	32.62	10.50	4.46	1.83	0.69
		v	36.26	23.38	14.79	9.07	5.76	3.65	2.31	1.63	1.13	0.76
3.40 l/s	204 l/min	R	12572.26	4046.21	1246.94	358.65	114.10	36.56	11.76	4.99	2.05	0.77
		v	38.53	24.85	15.71	9.63	6.12	3.88	2.45	1.73	1.20	0.80
3.60 l/s	216 l/min	R	14075.19	4527.04	1393.89	400.45	127.24	40.72	13.08	5.54	2.27	0.85
		v	40.79	26.31	16.63	10.20	6.48	4.11	2.60	1.83	1.27	0.85
3.80 l/s	228 l/min	R	15662.85	5034.79	1548.98	444.52	141.08	45.01	14.46	6.13	2.51	0.94
		v	43.06	27.77	17.56	10.77	6.84	4.34	2.74	1.94	1.34	0.90
4.00 l/s	240 l/min	R	17335.23	5569.45	1712.21	490.87	155.62	49.69	15.92	6.74	2.76	1.03
		v	45.33	29.23	18.48	11.33	7.20	4.57	2.89	2.04	1.41	0.95
4.20 l/s	252 l/min	R	19092.33	6131.02	1883.57	539.49	170.86	54.49	17.44	7.38	3.02	1.13
		v	47.59	30.69	19.41	11.90	7.56	4.79	3.03	2.14	1.49	0.99
4.40 l/s	264 l/min	R	20934.15	6719.50	2063.06	590.39	186.80	59.51	19.03	8.04	3.29	1.23
		v	49.86	32.15	20.33	12.46	7.92	5.02	3.18	2.24	1.56	1.04
4.60 l/s	276 l/min	R	22860.70	7334.89	2250.69	643.56	203.44	64.75	20.68	8.74	3.57	1.33
		v	52.13	33.61	21.25	13.03	8.28	5.25	3.32	2.34	1.63	1.09

V̇ = Volumetric current [l/s] R = Pressure gradient [mbar/m] v = Flow rate [m/s]

Pipe friction factor R and calculated flow rate v in dependence on the volumetric current \dot{V}

fusiotherm®-pipe SDR 6

Temperature: 60 °C

Roughness: 0.0070 mm

Density: 983.20 kg/m³

Viscosity: 0.47 x 10⁻⁶ m²/s

\dot{V}		Di- men- sion	16.0 mm	20.0 mm	25.0 mm	32.0 mm	40.0 mm	50.0 mm	63.0 mm	75.0 mm	90.0 mm	110.0 mm
4.80 l/s	288 l/min	R	24871.96	7977.19	2446.45	699.00	220.78	70.20	22.40	9.46	3.86	1.44
		v	54.39	35.08	22.18	13.60	8.64	5.48	3.46	2.44	1.70	1.13
5.00 l/s	300 l/min	R		8646.40	2650.34	756.72	238.81	75.87	24.19	10.20	4.16	1.55
		v		36.54	23.10	14.16	9.00	5.71	3.61	2.55	1.77	1.18
5.20 l/s	312 l/min	R		9342.51	2862.36	816.70	257.55	81.75	26.04	10.98	4.48	1.67
		v		38.00	24.03	14.73	9.36	5.94	3.75	2.65	1.84	1.23
5.40 l/s	324 l/min	R		10065.54	3082.51	878.96	276.98	87.85	27.96	11.78	4.80	1.79
		v		39.46	24.95	15.30	9.72	6.16	3.90	2.75	1.91	1.28
5.60 l/s	336 l/min	R		10815.47	3310.79	943.49	297.11	94.16	29.94	12.61	5.13	1.91
		v		40.92	25.88	15.86	10.08	6.39	4.04	2.85	1.98	1.32
5.80 l/s	348 l/min	R		11592.31	3547.20	1010.29	317.94	100.68	31.99	13.46	5.48	2.04
		v		42.38	26.80	16.43	10.44	6.62	4.19	2.95	2.05	1.37
6.00 l/s	360 l/min	R		12396.06	3791.75	1079.36	339.46	107.42	34.11	14.35	5.84	2.17
		v		43.84	27.72	17.00	10.80	6.85	4.33	3.06	2.12	1.42
6.20 l/s	372 l/min	R		13226.72	4044.42	1150.70	361.69	114.38	36.29	15.26	6.20	2.31
		v		45.31	28.65	17.56	11.16	7.08	4.48	3.16	2.19	1.47
6.40 l/s	384 l/min	R		14084.28	4305.22	1224.32	384.61	121.54	38.53	16.19	6.58	2.45
		v		46.77	29.57	18.13	11.52	7.30	4.62	3.26	2.26	1.51
6.60 l/s	396 l/min	R		14968.75	4574.15	1300.20	408.22	128.93	40.85	17.15	6.97	2.59
		v		48.23	30.50	18.70	11.88	7.53	4.76	3.36	2.33	1.56
6.80 l/s	408 l/min	R		15880.12	4851.21	1378.35	432.54	136.52	43.22	18.14	7.37	2.74
		v		49.69	31.42	19.26	12.24	7.76	4.91	3.46	2.41	1.61
7.00 l/s	420 l/min	R		16818.40	5136.40	1458.78	457.54	144.33	45.67	19.16	7.77	2.89
		v		51.15	32.34	19.83	12.60	7.99	5.05	3.57	2.48	1.65
7.50 l/s	450 l/min	R		19281.82	5884.94	1669.77	523.12	164.79	52.06	21.82	8.84	3.28
		v		54.81	34.65	21.25	13.50	8.56	5.41	3.82	2.65	1.77
8.00 l/s	480 l/min	R		21913.41	6684.29	1894.94	593.04	186.58	58.86	24.64	9.98	3.70
		v		58.46	36.96	22.66	14.40	9.13	5.77	4.07	2.83	1.89
9.00 l/s	540 l/min	R		27681.07	8435.39	2387.85	745.95	234.16	73.69	30.79	12.44	4.60
		v		65.77	41.59	25.50	16.20	10.27	6.50	4.58	3.18	2.13
10.0 l/s	600 l/min	R			10389.70	2937.49	916.25	287.08	90.15	37.60	15.16	5.60
		v			46.21	28.33	17.99	11.41	7.22	5.09	3.54	2.36
12.0 l/s	720 l/min	R			14907.94	4206.95	1309.05	408.88	127.92	53.20	21.39	7.87
		v			55.45	34.00	21.59	13.70	8.66	6.11	4.24	2.84
14.0 l/s	840 l/min	R			20238.98	5703.31	1771.41	551.98	172.19	71.43	28.64	10.51
		v			64.69	39.66	25.19	15.98	10.11	7.13	4.95	3.31
16.0 l/s	960 l/min	R				7426.54	2303.33	716.35	222.93	92.28	36.92	13.51
		v				45.33	28.79	18.26	11.55	8.15	5.66	3.78
18.0 l/s	1080 l/min	R				9376.64	2904.78	901.98	280.14	115.76	46.23	16.88
		v				50.99	32.39	20.54	12.99	9.17	6.37	4.25

\dot{V} = Volumetric current [l/s]

R = Pressure gradient [mbar/m]

v = Flow rate [m/s]

Pipe friction factor R and calculated flow rate v in dependence on the volumetric current \dot{V}

fusiotherm®-pipe SDR 6

Temperature: 60 °C

Roughness: 0.0070 mm Density: 983.20 kg/m³ Viscosity: 0.47 x 10⁻⁶ m²/s

\dot{V}		Di- men- sion	16.0 mm	20.0 mm	25.0 mm	32.0 mm	40.0 mm	50.0 mm	63.0 mm	75.0 mm	90.0 mm	110.0 mm
20.0 l/s	1200 l/min	R				11553.60	3575.78	1108.89	343.81	141.86	56.55	20.61
	v	v				56.66	35.99	22.83	14.44	10.19	7.07	4.73
22.0 l/s	1320 l/min	R				13957.43	4316.31	1337.05	413.95	170.57	67.89	24.70
	v	v				62.32	39.59	25.11	15.88	11.20	7.78	5.20
24.0 l/s	1440 l/min	R				16588.12	5126.37	1586.47	490.55	201.90	80.25	29.15
	v	v				67.99	43.19	27.39	17.32	12.22	8.49	5.67
26.0 l/s	1560 l/min	R					6005.96	1857.15	573.60	235.84	93.63	33.96
	v	v					46.79	29.68	18.77	13.24	9.20	6.14
28.0 l/s	1680 l/min	R					6955.08	2149.08	663.12	272.39	108.02	39.13
	v	v					50.39	31.96	20.21	14.26	9.90	6.62
30.0 l/s	1800 l/min	R					7973.73	2462.27	759.09	311.56	123.43	44.65
	v	v					53.98	34.24	21.65	15.28	10.61	7.09
32.0 l/s	1920 l/min	R					9061.90	2796.71	861.52	353.33	139.85	50.54
	v	v					57.58	36.52	23.01	16.30	11.32	7.56
34.0 l/s	2040 l/min	R					10219.61	3152.41	970.41	397.72	157.29	56.78
	v	v					61.18	38.81	24.54	17.32	12.03	8.04
36.0 l/s	2160 l/min	R					11446.84	3529.35	1085.75	444.71	175.73	63.38
	v	v					64.78	41.09	25.98	18.33	12.73	8.51
38.0 l/s	2280 l/min	R						3927.55	1207.54	494.31	195.20	70.34
	v	v						43.37	27.43	19.35	13.44	8.98
40.0 l/s	2400 l/min	R						4347.01	1335.79	546.53	215.67	77.65
	v	v						45.65	28.87	20.37	14.15	9.45
42.0 l/s	2520 l/min	R						4787.71	1470.50	601.35	237.16	85.32
	v	v						47.94	30.32	21.39	14.85	9.93
44.0 l/s	2640 l/min	R						5249.66	1611.66	658.78	259.66	93.34
	v	v						50.22	31.76	22.41	15.56	10.40
46.0 l/s	2760 l/min	R						5732.87	1759.27	718.82	283.18	101.73
	v	v						52.50	33.20	23.43	16.27	10.87
48.0 l/s	2880 l/min	R						6237.33	1913.34	781.47	307.70	110.46
	v	v						54.78	34.65	24.45	16.98	11.34
50.0 l/s	3000 l/min	R						6763.03	2073.86	846.72	333.24	119.56
	v	v						57.07	36.09	25.46	17.68	11.82
52.0 l/s	3120 l/min	R						7309.99	2240.83	914.58	359.79	129.01
	v	v						59.35	37.53	26.48	18.39	12.29
54.0 l/s	3240 l/min	R						7878.20	2414.26	985.06	387.36	138.82
	v	v						61.63	38.98	27.50	19.01	12.76
56.0 l/s	3360 l/min	R						8467.66	2594.14	1058.13	415.93	148.98
	v	v						63.92	40.42	28.52	19.81	13.23
58.0 l/s	3480 l/min	R						9078.37	2780.48	1133.82	445.52	159.50
	v	v						66.20	41.86	29.54	20.51	13.71

\dot{V} = Volumetric current [l/s] R = Pressure gradient [mbar/m] v = Flow rate [m/s]

Pipe friction factor R and calculated flow rate v in dependence on the volumetric current \dot{V}

fusiotherm®-pipe SDR 6

Temperature: 60 °C

Roughness: 0.0070 mm Density: 983.20 kg/m³ Viscosity: 0.47 x 10⁻⁶ m²/s

\dot{V}		Di- men- sion	16.0 mm	20.0 mm	25.0 mm	32.0 mm	40.0 mm	50.0 mm	63.0 mm	75.0 mm	90.0 mm	110.0 mm
60.0 l/s	3600 l/min	R							2973.26	1212.12	476.12	170.37
		v							43.31	30.56	21.22	14.18
62.0 l/s	3720 l/min	R							3172.51	1293.02	507.73	181.60
		v							44.75	31.58	21.93	14.65
64.0 l/s	3840 l/min	R							3378.20	1376.53	540.35	193.19
		v							46.19	32.59	22.64	15.13
66.0 l/s	3960 l/min	R							3590.35	1462.64	573.99	205.13
		v							47.64	33.61	23.34	15.60
68.0 l/s	4080 l/min	R							3808.95	1551.37	608.63	217.42
		v							49.08	34.63	24.05	16.07
70.0 l/s	4200 l/min	R							4034.00	1642.70	644.29	230.08
		v							50.53	35.65	24.76	16.54
72.0 l/s	4320 l/min	R							4265.51	1736.64	680.96	243.09
		v							51.97	36.67	25.46	17.02
74.0 l/s	4440 l/min	R							4503.47	1833.19	718.64	256.45
		v							53.41	37.69	26.17	17.49
76.0 l/s	4560 l/min	R							4747.88	1932.34	757.33	270.17
		v							54.86	38.71	26.88	17.96
78.0 l/s	4680 l/min	R							4998.74	2034.10	797.04	284.24
		v							56.30	39.73	27.59	18.43

\dot{V} = Volumetric current [l/s]

R = Pressure gradient [mbar/m]

v = Flow rate [m/s]

Pipe friction factor R and calculated flow rate v in dependence on the volumetric current V̇

fusiotherm®-faser composite pipe SDR 7.4 - fusiotherm®-stabi composite pipe SDR 7.4
Temperature: 60 °C

Roughness: 0.0070 mm Density: 983.20 kg/m³ Viscosity: 0.47 x 10⁻⁶ m²/s

V̇		Di- men- sion	16.0 mm	20.0 mm	25.0 mm	32.0 mm	40.0 mm	50.0 mm	63.0 mm	75.0 mm	90.0 mm	110.0 mm	125.0 mm	160.0 mm	200.0 mm	250.0 mm		
0.01 l/s	0.60 l/min	R	0.18	0.07	0.02	0.01	0.00	0.00	0.00	0.00	0.00	0.00	0.00	0.00	0.00	0.00	0.00	
		v	0.09	0.06	0.04	0.02	0.02	0.00	0.01	0.00	0.00	0.00	0.00	0.00	0.00	0.00	0.00	0.00
0.02 l/s	1.20 l/min	R	0.59	0.21	0.07	0.02	0.01	0.00	0.00	0.00	0.00	0.00	0.00	0.00	0.00	0.00	0.00	0.00
		v	0.19	0.12	0.08	0.05	0.03	0.02	0.01	0.01	0.01	0.01	0.00	0.00	0.00	0.00	0.00	0.00
0.03 l/s	1.80 l/min	R	1.19	0.43	0.15	0.04	0.02	0.01	0.00	0.00	0.00	0.00	0.00	0.00	0.00	0.00	0.00	0.00
		v	0.28	0.18	0.12	0.07	0.05	0.03	0.02	0.01	0.01	0.01	0.01	0.01	0.00	0.00	0.00	0.00
0.04 l/s	2.40 l/min	R	1.97	0.70	0.24	0.07	0.03	0.01	0.00	0.00	0.00	0.00	0.00	0.00	0.00	0.00	0.00	0.00
		v	0.38	0.25	0.16	0.09	0.06	0.04	0.02	0.02	0.01	0.01	0.01	0.01	0.00	0.00	0.00	0.00
0.05 l/s	3.00 l/min	R	2.91	1.04	0.36	0.11	0.04	0.01	0.00	0.00	0.00	0.00	0.00	0.00	0.00	0.00	0.00	0.00
		v	0.47	0.31	0.20	0.12	0.08	0.05	0.03	0.02	0.01	0.01	0.01	0.01	0.01	0.01	0.00	0.00
0.06 l/s	3.60 l/min	R	4.02	1.43	0.49	0.15	0.05	0.02	0.01	0.00	0.00	0.00	0.00	0.00	0.00	0.00	0.00	0.00
		v	0.57	0.37	0.24	0.14	0.09	0.06	0.04	0.03	0.02	0.01	0.01	0.01	0.01	0.01	0.00	0.00
0.07 l/s	4.20 l/min	R	5.28	1.87	0.64	0.19	0.07	0.02	0.01	0.00	0.00	0.00	0.00	0.00	0.00	0.00	0.00	0.00
		v	0.66	0.43	0.28	0.17	0.11	0.07	0.04	0.03	0.02	0.01	0.01	0.01	0.01	0.01	0.00	0.00
0.08 l/s	4.80 l/min	R	6.70	2.37	0.81	0.24	0.08	0.03	0.00	0.00	0.00	0.00	0.00	0.00	0.00	0.00	0.00	0.00
		v	0.76	0.49	0.31	0.19	0.12	0.08	0.05	0.03	0.02	0.02	0.02	0.01	0.01	0.01	0.01	0.00
0.09 l/s	5.40 l/min	R	8.27	2.92	1.00	0.30	0.10	0.04	0.01	0.01	0.00	0.00	0.00	0.00	0.00	0.00	0.00	0.00
		v	0.85	0.55	0.35	0.21	0.14	0.09	0.05	0.04	0.03	0.02	0.02	0.01	0.01	0.01	0.01	0.01
0.10 l/s	6.00 l/min	R	10.00	3.52	1.20	0.36	0.12	0.04	0.01	0.01	0.00	0.00	0.00	0.00	0.00	0.00	0.00	0.00
		v	0.95	0.61	0.39	0.24	0.15	0.01	0.06	0.04	0.03	0.02	0.02	0.02	0.01	0.01	0.01	0.00
0.12 l/s	7.20 l/min	R	13.88	4.87	1.66	0.49	0.17	0.06	0.02	0.01	0.00	0.00	0.00	0.00	0.00	0.00	0.00	0.00
		v	1.14	0.74	0.47	0.28	0.18	0.12	0.07	0.05	0.04	0.02	0.02	0.02	0.01	0.01	0.01	0.01
0.16 l/s	9.60 l/min	R	23.39	8.16	2.77	0.82	0.28	0.01	0.03	0.01	0.01	0.00	0.00	0.00	0.00	0.00	0.00	0.00
		v	1.51	0.98	0.63	0.38	0.24	0.16	0.01	0.07	0.05	0.03	0.02	0.02	0.02	0.00	0.00	0.01
0.18 l/s	10.8 l/min	R	28.99	10.01	3.43	1.00	0.35	0.12	0.04	0.02	0.01	0.00	0.00	0.00	0.00	0.00	0.00	0.00
		v	1.70	1.11	0.71	0.43	0.27	0.17	0.11	0.08	0.05	0.04	0.03	0.03	0.02	0.01	0.01	0.01
0.20 l/s	12.0 l/min	R	35.16	12.22	4.14	1.22	0.42	0.14	0.05	0.02	0.01	0.00	0.00	0.00	0.00	0.00	0.00	0.00
		v	1.89	1.23	0.79	0.47	0.30	0.19	0.12	0.09	0.06	0.04	0.03	0.03	0.02	0.01	0.01	0.01
0.30 l/s	18.0 l/min	R	74.30	25.60	8.60	2.51	0.86	0.30	0.01	0.04	0.02	0.01	0.00	0.00	0.00	0.00	0.00	0.00
		v	2.84	1.84	1.18	0.71	0.45	0.29	0.18	0.13	0.09	0.06	0.05	0.05	0.03	0.02	0.02	0.01
0.40 l/s	24.0 l/min	R	127.07	43.49	14.53	4.22	1.43	0.49	0.16	0.07	0.03	0.01	0.01	0.00	0.00	0.00	0.00	0.00
		v	3.78	2.46	1.57	0.95	0.61	0.39	0.24	0.17	0.12	0.08	0.06	0.06	0.04	0.02	0.02	0.02
0.50 l/s	30.0 l/min	R	193.33	65.82	21.88	6.33	2.14	0.73	0.24	0.10	0.04	0.02	0.01	0.00	0.00	0.00	0.00	0.00
		v	4.73	3.07	1.96	1.18	0.76	0.49	0.30	0.22	0.15	0.10	0.08	0.08	0.05	0.03	0.03	0.02
0.60 l/s	36.0 l/min	R	272.98	92.54	30.64	8.82	2.98	1.02	0.33	0.14	0.06	0.02	0.01	0.00	0.00	0.00	0.00	0.00
		v	5.68	3.68	2.36	1.42	0.91	0.58	0.36	0.26	0.18	0.12	0.09	0.09	0.06	0.04	0.04	0.02
0.70 l/s	42.0 l/min	R	365.98	123.62	40.78	11.70	3.94	1.34	0.43	0.19	0.08	0.03	0.02	0.01	0.00	0.00	0.00	0.00
		v	6.62	4.30	2.75	1.66	1.06	0.68	0.42	0.30	0.21	0.14	0.11	0.11	0.07	0.04	0.04	0.03

V̇ = Volumetric current [l/s] R = Pressure gradient [mbar/m] v = Flow rate [m/s]

Pipe friction factor R and calculated flow rate v in dependence on the volumetric current \dot{V}

fusiotherm®-faser composite pipe SDR 7.4 - fusiotherm®-stabi composite pipe SDR 7.4

Temperature: 60 °C

Roughness: 0.0070 mm

Density: 983.20 kg/m³

Viscosity: 0.47 x 10⁻⁶ m²/s

\dot{V}		Di- men- sion	16.0 mm	20.0 mm	25.0 mm	32.0 mm	40.0 mm	50.0 mm	63.0 mm	75.0 mm	90.0 mm	110.0 mm	125.0 mm	160.0 mm	200.0 mm	250.0 mm
0.80	48.0	R	472.28	159.04	52.30	14.96	5.02	1.71	0.55	0.24	0.01	0.04	0.02	0.01	0.00	0.00
	l/s	v	7.57	4.91	3.14	1.89	1.21	0.78	0.49	0.34	0.24	0.16	0.12	0.08	0.05	0.03
0.90	54.0	R	591.88	198.78	65.19	18.59	6.23	2.12	0.68	0.30	0.12	0.05	0.03	0.01	0.00	0.00
	l/s	v	8.52	5.53	3.54	2.13	1.36	0.87	0.55	0.39	0.27	0.18	0.14	0.08	0.05	0.04
1.00	60.0	R	724.75	242.84	79.44	22.59	7.55	2.56	0.82	0.36	0.15	0.06	0.03	0.01	0.00	0.00
	l/s	v	9.46	6.14	3.93	2.37	1.51	0.97	0.61	0.43	0.30	0.20	0.15	0.09	0.06	0.04
1.20	72.0	R	1030.26	343.86	112.01	31.70	10.56	3.57	1.14	0.50	0.20	0.08	0.04	0.01	0.01	0.00
	l/s	v	11.35	7.37	4.72	2.84	1.82	1.17	0.73	0.52	0.36	0.24	0.19	0.11	0.07	0.05
1.40	84.0	R	1388.77	462.05	149.97	42.27	14.04	4.74	1.51	0.66	0.27	0.10	0.06	0.02	0.01	0.00
	l/s	v	13.25	8.60	5.50	3.31	2.12	1.36	0.85	0.60	0.42	0.28	0.22	0.13	0.08	0.05
1.60	96.0	R	1800.22	597.40	193.32	54.30	17.98	6.05	1.92	0.83	0.34	0.13	0.07	0.02	0.01	0.00
	l/s	v	15.14	9.82	6.29	3.78	2.42	1.55	0.97	0.69	0.48	0.32	0.25	0.15	0.01	0.06
1.80	108	R	2264.61	749.88	242.05	67.78	22.38	7.52	2.38	1.03	0.42	0.16	0.09	0.03	0.01	0.00
	l/s	v	17.03	11.05	7.07	4.26	2.73	1.75	1.09	0.77	0.54	0.36	0.28	0.17	0.11	0.07
2.00	120	R	2781.91	919.48	296.13	82.69	27.25	9.13	2.89	1.25	0.51	0.20	0.11	0.03	0.01	0.00
	l/s	v	18.92	12.28	7.86	4.73	3.03	1.94	1.21	0.86	0.60	0.40	0.31	0.19	0.12	0.08
2.20	132	R	3352.11	1106.20	355.57	99.05	32.57	10.89	3.44	1.49	0.61	0.23	0.13	0.04	0.01	0.01
	l/s	v	20.82	13.51	8.65	5.20	3.33	2.14	1.34	0.95	0.65	0.44	0.34	0.21	0.13	0.09
2.40	144	R	3975.21	1310.01	420.36	116.84	38.34	12.80	4.04	1.74	0.71	0.27	0.15	0.04	0.02	0.01
	l/s	v	22.71	14.74	9.43	5.68	3.63	2.33	1.46	1.03	0.71	0.48	0.37	0.23	0.14	0.09
2.60	156	R	4651.20	1530.92	490.49	136.06	44.57	14.85	4.68	2.02	0.83	0.32	0.17	0.05	0.02	0.01
	l/s	v	24.60	15.96	10.22	6.15	3.94	2.53	1.58	1.12	0.77	0.52	0.40	0.25	0.16	0.10
2.80	168	R	5380.07	1768.93	565.97	156.72	51.25	17.05	5.36	2.31	0.94	0.36	0.19	0.06	0.02	0.01
	l/s	v	26.49	17.19	11.00	6.62	4.24	2.72	1.70	1.20	0.83	0.56	0.43	0.26	0.17	0.11
3.00	180	R	6161.83	2024.03	646.79	178.80	58.38	19.39	6.09	2.62	1.07	0.41	0.22	0.07	0.02	0.01
	l/s	v	28.39	18.42	11.79	7.01	4.54	2.91	1.82	1.29	0.89	0.60	0.46	0.28	0.18	0.12
3.20	192	R	6996.46	2296.22	732.95	202.31	65.96	21.88	6.86	2.95	1.20	0.46	0.25	0.07	0.03	0.01
	l/s	v	30.28	19.65	12.58	7.57	4.84	3.11	1.94	1.38	0.95	0.64	0.49	0.30	0.19	0.13
3.40	204	R	7883.98	2585.49	824.44	227.25	73.99	24.51	7.67	3.30	1.35	0.51	0.27	0.08	0.03	0.01
	l/s	v	32.17	20.88	13.36	8.04	5.15	3.30	2.06	1.46	1.01	0.68	0.53	0.32	0.21	0.13
3.60	216	R	8824.36	2891.85	921.27	253.61	82.47	27.29	8.53	3.67	1.49	0.57	0.30	0.09	0.03	0.01
	l/s	v	34.06	22.10	14.15	8.52	5.45	3.50	2.19	1.55	1.07	0.72	0.56	0.34	0.22	0.14
3.80	228	R	9817.63	3215.30	1023.43	281.40	91.40	30.21	9.43	4.05	1.65	0.63	0.34	0.10	0.03	0.01
	l/s	v	35.96	23.33	14.93	8.99	5.75	3.69	2.31	1.63	1.13	0.76	0.59	0.36	0.23	0.15
4.00	240	R	10863.77	3555.83	1130.93	310.61	100.78	33.27	10.38	4.45	1.81	0.69	0.37	0.11	0.04	0.01
	l/s	v	37.85	24.56	15.72	9.46	6.06	3.89	2.43	1.72	1.19	0.80	0.62	0.38	0.24	0.16
4.20	252	R	11962.78	3913.44	1243.75	341.24	110.60	36.47	11.37	4.88	1.98	0.75	0.40	0.12	0.04	0.01
	l/s	v	39.74	25.79	16.50	9.94	6.36	4.08	2.55	1.81	1.25	0.84	0.65	0.40	0.25	0.16
4.40	264	R	13114.66	4288.14	1361.91	373.30	120.87	39.82	12.40	5.31	2.16	0.82	0.44	0.13	0.05	0.02
	l/s	v	41.63	27.02	17.29	10.41	6.66	4.28	2.67	1.89	1.31	0.88	0.68	0.41	0.27	0.17

\dot{V} = Volumetric current [l/s]

R = Pressure gradient [mbar/m]

v = Flow rate [m/s]

Pipe friction factor R and calculated flow rate v in dependence on the volumetric current V̇

fusiotherm®-faser composite pipe SDR 7.4 - fusiotherm®-stabi composite pipe SDR 7.4

Temperature: 60 °C

Roughness: 0.0070 mm Density: 983.20 kg/m³ Viscosity: 0.47 x 10⁻⁶ m²/s

V̇		Di- men- sion	16.0 mm	20.0 mm	25.0 mm	32.0 mm	40.0 mm	50.0 mm	63.0 mm	75.0 mm	90.0 mm	110.0 mm	125.0 mm	160.0 mm	200.0 mm	250.0 mm
4.60 l/s	276 l/min	R	14319.42	4679.91	1485.40	406.78	131.59	43.31	13.47	5.77	2.34	0.89	0.47	0.14	0.05	0.02
		v	43.53	28.25	18.08	10.88	6.96	4.47	2.79	1.98	1.37	0.92	0.71	0.43	0.28	0.18
4.80 l/s	288 l/min	R	15577.04	5088.77	1614.23	441.68	142.75	46.94	14.58	6.24	2.53	0.96	0.51	0.16	0.05	0.02
		v	45.42	29.47	18.86	11.35	7.27	4.66	2.91	2.07	1.43	0.96	0.74	0.45	0.29	0.19
5.00 l/s	300 l/min	R		5514.70	1748.38	478.00	154.36	50.71	15.74	6.73	2.73	1.03	0.55	0.17	0.06	0.02
		v		30.70	19.65	11.83	7.57	4.86	3.03	2.15	1.49	1.00	0.77	0.47	0.30	0.20
5.20 l/s	312 l/min	R		5957.72	1887.86	515.74	166.42	54.62	16.94	7.24	2.93	1.11	0.59	0.18	0.06	0.02
		v		31.93	20.43	12.30	7.87	5.05	3.16	2.24	1.55	1.04	0.80	0.49	0.31	0.20
5.40 l/s	324 l/min	R		6417.82	2032.67	554.90	178.92	58.68	18.18	7.77	3.15	1.19	0.64	0.19	0.07	0.02
		v		33.16	21.22	12.77	8.18	5.25	3.28	2.32	1.61	1.08	0.83	0.51	0.33	0.21
5.60 l/s	336 l/min	R		6894.99	2182.82	595.49	191.87	62.88	19.47	8.31	3.36	1.27	0.68	0.21	0.07	0.02
		v		34.39	22.01	13.25	8.48	5.44	3.40	2.41	1.67	1.12	0.86	0.53	0.34	0.22
5.80 l/s	348 l/min	R		7389.25	2338.29	637.49	205.26	67.21	20.80	8.88	3.59	1.36	0.72	0.22	0.07	0.03
		v		35.61	22.79	13.72	8.78	5.64	3.52	2.50	1.73	1.16	0.90	0.55	0.35	0.23
6.00 l/s	360 l/min	R		7900.58	2499.08	680.92	219.10	71.69	22.17	9.46	3.82	1.44	0.77	0.23	0.08	0.03
		v		36.84	23.58	14.19	9.08	5.83	3.64	2.58	1.79	1.20	0.93	0.57	0.36	0.23
6.20 l/s	372 l/min	R		8428.99	2665.21	725.76	233.38	76.32	23.58	10.05	4.06	1.53	0.82	0.25	0.08	0.03
		v		38.07	24.36	14.67	9.39	6.02	3.76	2.67	1.85	1.24	0.96	0.58	0.37	0.24
6.40 l/s	384 l/min	R		8974.48	2836.67	772.03	248.11	81.08	25.03	10.67	4.31	1.63	0.87	0.26	0.09	0.03
		v		39.30	25.15	15.14	9.69	6.22	3.88	2.75	1.91	1.28	0.99	0.60	0.39	0.25
6.60 l/s	396 l/min	R		9537.05	3013.45	819.71	263.29	85.98	26.52	11.30	4.56	1.72	0.92	0.28	0.09	0.03
		v		40.53	25.94	15.61	9.99	6.41	4.01	2.84	1.96	1.32	1.02	0.62	0.40	0.26
6.80 l/s	408 l/min	R		10116.69	3195.57	868.81	278.91	91.03	28.06	11.95	4.82	1.82	0.97	0.29	0.10	0.04
		v		41.75	26.72	16.09	10.29	6.61	4.13	2.93	2.02	1.36	1.05	0.64	0.41	0.27
7.00 l/s	420 l/min	R		10713.42	3383.01	919.34	294.97	96.21	29.64	12.61	5.09	1.92	1.02	0.31	0.11	0.04
		v		42.98	27.51	16.56	10.60	6.80	4.25	3.01	2.08	1.40	1.08	0.66	0.42	0.27
7.50 l/s	450 l/min	R		12279.94	3874.92	1051.85	337.07	109.79	33.77	14.36	5.78	2.18	1.16	0.35	0.12	0.04
		v		46.05	29.47	17.74	11.35	7.29	4.55	3.23	2.23	1.50	1.16	0.71	0.45	0.29
8.00 l/s	480 l/min	R		13953.20	4400.13	1193.24	381.96	124.25	38.16	16.21	6.52	2.45	1.31	0.39	0.13	0.05
		v		49.12	31.44	18.92	12.11	7.77	4.86	3.44	2.38	1.60	1.24	0.75	0.48	0.31
9.00 l/s	540 l/min	R		17619.93	5550.43	1502.62	480.05	155.80	47.73	20.23	8.12	3.05	1.62	0.49	0.17	0.06
		v		55.26	35.37	21.29	13.63	8.74	5.46	3.87	2.68	1.80	1.39	0.85	0.54	0.35
10.0 l/s	600 l/min	R			6833.92	1847.46	589.25	190.87	58.34	24.68	9.89	3.71	1.97	0.59	0.20	0.07
		v			39.30	23.66	15.14	9.72	6.07	4.30	2.98	2.00	1.54	0.94	0.60	0.39
12.0 l/s	720 l/min	R			9800.41	2643.53	840.94	271.52	82.66	34.87	13.94	5.21	2.76	0.83	0.28	0.01
		v			47.16	28.39	18.17	11.66	7.28	5.16	3.57	2.40	1.85	1.13	0.72	0.47
14.0 l/s	840 l/min	R			13299.58	3581.42	1137.00	366.18	111.13	46.77	18.64	6.95	3.68	1.01	0.37	0.13
		v			55.02	33.12	21.20	13.60	8.50	6.02	4.17	2.80	2.16	1.32	0.85	0.55
16.0 l/s	960 l/min	R				4661.12	1477.42	474.85	143.74	60.36	24.00	8.93	4.72	1.40	0.47	0.17
		v				37.85	24.22	15.55	9.71	6.88	4.76	3.20	2.47	1.51	0.97	0.63

V̇ = Volumetric current [l/s] R = Pressure gradient [mbar/m] v = Flow rate [m/s]

Pipe friction factor R and calculated flow rate v in dependence on the volumetric current \dot{V}

fusiotherm®-faser composite pipe SDR 7.4 - fusiotherm®-stabi composite pipe SDR 7.4

Temperature: 60 °C

Roughness: 0.0070 mm

Density: 983.20 kg/m³

Viscosity: 0.47 x 10⁻⁶ m²/s

\dot{V}		Di- men- sion	16 mm	20 mm	25 mm	32 mm	40 mm	50 mm	63 mm	75 mm	90 mm	110 mm	125 mm	160 mm	200 mm	250 mm
18.0 l/s	1080 l/min	R				5882.62	1862.20	597.51	180.47	75.65	30.02	11.14	5.88	1.75	0.59	0.20
	v	v				42.58	27.25	17.49	10.93	7.74	5.36	3.60	2.78	1.70	1.09	0.70
20.0 l/s	1200 l/min	R				7245.92	2291.32	734.16	221.33	92.63	36.70	13.59	7.16	2.12	0.71	0.25
	v	v				47.31	30.28	19.43	12.14	8.60	5.95	4.00	3.09	1.89	1.21	0.78
22.0 l/s	1320 l/min	R				8751.01	2764.79	884.80	266.31	111.30	44.02	16.28	8.57	2.54	0.85	0.30
	v	v				52.04	33.31	21.38	13.35	9.47	6.55	4.40	3.40	2.07	1.33	0.86
24.0 l/s	1440 l/min	R				10397.90	3282.60	1049.43	315.41	131.66	52.00	19.20	10.01	2.98	1.00	0.35
	v	v				56.77	36.34	23.32	14.57	10.33	7.14	4.80	3.71	2.26	1.45	0.94
26.0 l/s	1560 l/min	R					3844.75	1228.04	368.63	153.71	60.63	22.35	11.74	3.46	1.16	0.40
	v	v					39.36	25.26	15.78	11.19	7.74	5.20	4.02	2.45	1.57	1.02
28.0 l/s	1680 l/min	R					4451.23	1420.64	425.97	177.44	69.91	25.74	13.51	3.98	1.33	0.46
	v	v					42.39	27.21	17.00	12.05	8.34	5.60	4.32	2.64	1.69	1.01
30.0 l/s	1800 l/min	R					5102.06	1627.21	487.43	202.86	79.84	29.36	15.40	4.53	1.51	0.52
	v	v					45.42	29.15	18.21	12.91	8.93	6.00	4.63	2.83	1.81	1.17
32.0 l/s	1920 l/min	R					5797.23	1847.77	553.00	229.97	90.42	33.21	17.41	5.11	1.71	0.59
	v	v					48.45	31.09	19.42	13.77	9.53	6.40	4.94	3.02	1.93	1.25
34.0 l/s	2040 l/min	R					6536.73	2082.31	622.69	258.76	101.65	37.30	19.53	5.73	1.91	0.66
	v	v					51.47	33.03	20.64	14.63	10.12	6.80	5.25	3.21	2.05	1.33
36.0 l/s	2160 l/min	R					7320.56	2330.83	696.50	289.24	113.53	41.61	21.78	6.38	2.12	0.73
	v	v					54.50	34.98	21.85	15.49	10.72	7.20	5.56	3.39	2.17	1.41
38.0 l/s	2280 l/min	R						2593.33	774.42	321.40	126.06	46.16	24.15	7.07	2.35	0.81
	v	v						36.92	23.07	16.35	11.31	7.60	5.87	3.58	2.29	1.49
40.0 l/s	2400 l/min	R						2869.81	856.46	355.25	139.23	50.94	26.63	7.78	2.59	0.89
	v	v						38.86	24.28	17.21	11.91	8.00	6.18	3.77	2.42	1.56
42.0 l/s	2520 l/min	R						3160.26	942.61	390.77	153.06	55.95	29.24	8.54	2.83	0.97
	v	v						40.81	25.49	18.07	12.50	8.40	6.49	3.96	2.54	1.64
44.0 l/s	2640 l/min	R						3464.70	1032.88	427.99	167.53	61.20	31.96	9.32	3.09	1.06
	v	v						42.75	26.71	18.93	13.01	8.80	6.80	4.15	2.66	1.72
46.0 l/s	2760 l/min	R						3783.12	1127.26	466.88	182.65	66.67	34.80	10.14	3.36	1.15
	v	v						44.69	27.92	19.79	13.69	9.20	7.10	4.34	2.78	1.80
48.0 l/s	2880 l/min	R						4115.51	1225.76	507.46	198.41	72.38	37.76	10.99	3.64	1.25
	v	v						46.64	29.14	20.65	14.29	9.60	7.41	4.53	2.90	1.88
50.0 l/s	3000 l/min	R						4461.88	1328.37	549.73	214.83	78.31	40.84	11.88	3.93	1.35
	v	v						48.58	30.35	21.51	14.88	10.00	7.72	4.71	3.02	1.96
52.0 l/s	3120 l/min	R						4822.23	1435.09	593.67	231.89	84.48	44.04	12.80	4.23	1.45
	v	v						50.52	31.56	22.37	15.48	10.40	8.03	4.90	3.14	2.03
54.0 l/s	3240 l/min	R						5196.56	1545.93	639.30	249.60	90.88	47.35	13.75	4.54	1.56
	v	v						52.47	32.78	23.23	16.07	10.80	8.34	5.09	3.26	2.11
56.0 l/s	3360 l/min	R						5584.87	1660.88	686.61	267.95	97.51	50.79	14.74	4.87	1.67
	v	v						54.41	33.99	24.09	16.67	11.20	8.65	5.28	3.38	2.19

\dot{V} = Volumetric current [l/s]

R = Pressure gradient [mbar/m]

v = Flow rate [m/s]

Pipe friction factor R and calculated flow rate v in dependence on the volumetric current \dot{V}

fusiotherm®-faser composite pipe SDR 7.4 - fusiotherm®-stabi composite pipe SDR 7.4
Temperature: 60 °C

Roughness: 0.0070 mm Density: 983.20 kg/m³ Viscosity: 0.47 x 10⁶ m²/s

\dot{V}		Di- men- sion	16.0 mm	20.0 mm	25.0 mm	32.0 mm	40.0 mm	50.0 mm	63.0 mm	75.0 mm	90.0 mm	110.0 mm	125.0 mm	160.0 mm	200.0 mm	250.0 mm
58.0 l/s	3480 l/min	R						598715	1779.95	735.60	286.95	104.37	54.34	15.75	5.20	1.78
		v						56.35	35.21	24.95	17.27	11.60	8.96	5.47	3.50	2.27
60.0 l/s	3600 l/min	R							1903.13	786.28	306.60	111.46	58.01	16.81	5.54	1.90
		v							36.42	25.81	17.86	12.00	9.27	5.66	3.62	2.35
62.0 l/s	3720 l/min	R							2030.42	838.64	326.90	118.78	61.80	17.89	5.90	2.02
		v							37.63	26.67	18.46	12.40	9.57	5.85	3.74	2.43
64.0 l/s	3840 l/min	R							2161.83	892.68	347.85	126.34	65.71	19.01	6.26	2.14
		v							38.85	27.54	19.05	12.80	9.88	6.04	3.87	2.50
66.0 l/s	3960 l/min	R							2297.35	948.41	369.44	134.12	69.73	20.16	6.64	2.27
		v							40.06	28.40	19.65	13.20	10.19	6.22	3.99	2.58
68.0 l/s	4080 l/min	R							2436.99	1005.82	391.67	142.13	73.88	21.35	7.02	2.40
		v							41.28	29.26	20.24	13.60	10.50	6.41	4.11	2.66
70.0 l/s	4200 l/min	R							2580.74	1064.91	414.56	150.38	78.14	22.56	7.42	2.53
		v							42.49	30.12	20.84	14.00	10.81	6.60	4.23	2.74
72.0 l/s	4320 l/min	R							2728.60	1125.68	438.09	158.85	82.52	23.82	7.82	2.67
		v							43.70	30.98	21.43	14.40	11.12	6.79	4.35	2.82
74.0 l/s	4440 l/min	R							2880.58	1188.13	462.27	167.56	87.02	25.01	8.24	2.81
		v							44.92	31.84	22.03	14.80	11.43	6.98	4.47	2.90
76.0 l/s	4560 l/min	R							3036.66	1252.27	487.01	176.50	91.64	26.42	8.67	2.95
		v							46.13	32.70	22.62	15.20	11.74	7.17	4.59	2.97
78.0 l/s	4680 l/min	R							3196.87	1318.09	512.57	185.66	96.37	27.77	9.11	3.10
		v							47.35	33.56	23.22	15.60	12.05	7.36	4.71	3.05
80.0 l/s	4800 l/min	R							3361.18	1385.59	538.69	195.06	101.23	29.15	9.56	3.25
		v							48.56	34.42	23.81	16.00	12.35	7.54	4.83	3.13
85.0 l/s	5100 l/min	R							3789.97	1561.70	606.81	219.56	113.88	32.75	10.73	3.65
		v							51.59	36.57	25.30	17.00	13.13	8.02	5.13	3.33
90.0 l/s	5400 l/min	R							4244.46	1748.33	678.98	245.50	127.26	36.56	11.96	4.06
		v							54.63	38.72	26.79	17.99	13.90	8.49	5.44	3.52
95.0 l/s	5700 l/min	R								1945.47	755.19	272.88	141.39	40.58	13.26	4.50
		v								40.87	28.28	18.99	14.67	8.96	5.74	3.72
100.0 l/s	6000 l/min	R								2153.13	835.44	301.70	156.25	44.80	14.63	4.96
		v								43.02	29.77	19.99	15.44	9.43	6.04	3.91
105.0 l/s	6300 l/min	R								2371.30	919.73	331.96	171.85	49.22	16.06	5.44
		v								45.18	31.26	20.99	16.22	9.90	6.34	4.11

\dot{V} = Volumetric current [l/s] R = Pressure gradient [mbar/m] v = Flow rate [m/s]

Pipe friction factor R and calculated flow rate v in dependence on the volumetric current \dot{V}

climatherm-pipe SDR 11 - climatherm-faser composite pipe SDR 11

Temperature: 10 °C

Roughness: 0.0070 mm Density: 999.6 kg/m³ Viscosity: 1.297 x 10⁻⁶ m²/s

\dot{V}		Di- men- sion	20.0 mm	25.0 mm	32.0 mm	40.0 mm	50.0 mm	63.0 mm	75.0 mm	90.0 mm	110.0 mm	125.0 mm	160.0 mm	200.0 mm	250.0 mm
0.01 l/s	0.60 l/min	R	0.05	0.02	0.01	0.00	0.00	0.00	0.00	0.00	0.00	0.00	0.00	0.00	0.00
		v	0.05	0.03	0.02	0.01	0.01	0.01	0.00	0.00	0.00	0.00	0.00	0.00	0.00
0.02 l/s	1.20 l/min	R	0.17	0.06	0.02	0.01	0.00	0.00	0.00	0.00	0.00	0.00	0.00	0.00	0.00
		v	0.01	0.06	0.04	0.02	0.02	0.00	0.01	0.01	0.00	0.00	0.00	0.00	0.00
0.03 l/s	1.80 l/min	R	0.34	0.11	0.04	0.01	0.01	0.00	0.00	0.00	0.00	0.00	0.00	0.00	0.00
		v	0.15	0.09	0.06	0.04	0.02	0.01	0.01	0.01	0.01	0.00	0.00	0.00	0.00
0.04 l/s	2.40 l/min	R	0.54	0.18	0.06	0.02	0.01	0.00	0.00	0.00	0.00	0.00	0.00	0.00	0.00
		v	0.19	0.12	0.07	0.05	0.03	0.02	0.01	0.01	0.01	0.01	0.00	0.00	0.00
0.05 l/s	3.00 l/min	R	0.79	0.27	0.08	0.03	0.01	0.00	0.00	0.00	0.00	0.00	0.00	0.00	0.00
		v	0.24	0.15	0.09	0.06	0.04	0.02	0.02	0.02	0.01	0.01	0.01	0.00	0.00
0.06 l/s	3.60 l/min	R	1.08	0.37	0.11	0.04	0.01	0.01	0.00	0.00	0.00	0.00	0.00	0.00	0.00
		v	0.29	0.18	0.11	0.07	0.05	0.03	0.02	0.01	0.01	0.01	0.00	0.00	0.00
0.07 l/s	4.20 l/min	R	1.41	0.48	0.15	0.05	0.02	0.01	0.00	0.00	0.00	0.00	0.00	0.00	0.00
		v	0.34	0.21	0.13	0.08	0.05	0.03	0.02	0.02	0.01	0.01	0.01	0.00	0.00
0.08 l/s	4.80 l/min	R	1.78	0.60	0.18	0.07	0.02	0.01	0.00	0.00	0.00	0.00	0.00	0.00	0.00
		v	0.39	0.24	0.15	0.01	0.06	0.04	0.03	0.02	0.01	0.00	0.01	0.00	0.00
0.09 l/s	5.40 l/min	R	2.17	0.73	0.22	0.08	0.03	0.00	0.00	0.00	0.00	0.00	0.00	0.00	0.00
		v	0.44	0.28	0.17	0.11	0.07	0.04	0.03	0.02	0.01	0.01	0.01	0.00	0.00
0.10 l/s	6.00 l/min	R	2.61	0.88	0.27	0.01	0.03	0.01	0.01	0.00	0.00	0.00	0.00	0.00	0.00
		v	0.49	0.31	0.19	0.12	0.08	0.05	0.03	0.02	0.02	0.01	0.01	0.01	0.01
0.12 l/s	7.20 l/min	R	3.58	1.20	0.37	0.13	0.05	0.02	0.01	0.00	0.00	0.00	0.00	0.00	0.00
		v	0.58	0.37	0.22	0.14	0.09	0.06	0.04	0.03	0.02	0.01	0.01	0.01	0.01
0.16 l/s	9.60 l/min	R	5.91	1.97	0.60	0.21	0.07	0.03	0.01	0.01	0.00	0.00	0.00	0.00	0.00
		v	0.78	0.49	0.30	0.19	0.12	0.08	0.05	0.04	0.03	0.02	0.01	0.01	0.01
0.18 l/s	10.8 l/min	R	7.26	2.42	0.74	0.26	0.09	0.03	0.01	0.01	0.00	0.00	0.00	0.00	0.00
		v	0.87	0.55	0.33	0.22	0.14	0.09	0.06	0.04	0.03	0.02	0.01	0.01	0.01
0.20 l/s	12.0 l/min	R	8.74	2.91	0.89	0.31	0.11	0.04	0.02	0.01	0.00	0.00	0.00	0.00	0.00
		v	0.97	0.61	0.37	0.24	0.15	0.01	0.07	0.05	0.03	0.02	0.01	0.00	0.01
0.30 l/s	18.0 l/min	R	17.89	5.92	1.79	0.63	0.22	0.07	0.03	0.01	0.01	0.00	0.00	0.00	0.00
		v	1.46	0.92	0.56	0.36	0.23	0.14	0.10	0.07	0.05	0.04	0.02	0.01	0.01
0.40 l/s	24.0 l/min	R	29.88	9.85	2.97	1.05	0.36	0.12	0.05	0.02	0.01	0.01	0.00	0.00	0.00
		v	1.94	1.22	0.74	0.48	0.31	0.19	0.14	0.09	0.06	0.05	0.03	0.02	0.01
0.50 l/s	30.0 l/min	R	44.59	14.65	4.41	1.55	0.53	0.18	0.08	0.03	0.01	0.01	0.00	0.00	0.00
		v	2.43	1.53	0.93	0.60	0.38	0.24	0.17	0.12	0.08	0.06	0.04	0.02	0.02
0.60 l/s	36.0 l/min	R	61.95	20.29	6.09	2.14	0.73	0.24	0.10	0.04	0.02	0.01	0.00	0.00	0.00
		v	2.91	1.84	1.11	0.72	0.46	0.29	0.20	0.14	0.09	0.07	0.04	0.03	0.02
0.70 l/s	42.0 l/min	R	81.91	26.76	8.01	2.81	0.96	0.32	0.14	0.06	0.02	0.01	0.00	0.00	0.00
		v	3.40	2.14	1.30	0.84	0.54	0.34	0.24	0.16	0.11	0.09	0.05	0.03	0.02
0.80 l/s	48.0 l/min	R	104.43	34.03	10.16	3.56	1.22	0.40	0.17	0.07	0.03	0.02	0.01	0.00	0.00
		v	3.88	2.45	1.48	0.96	0.61	0.39	0.27	0.19	0.13	0.01	0.06	0.04	0.02

\dot{V} = Volumetric current [l/s]

R = Pressure gradient [mbar/m]

v = Flow rate [m/s]

Pipe friction factor R and calculated flow rate v in dependence on the volumetric current V̇

climatherm-pipe SDR 11 - climatherm-faser composite pipe SDR 11

Temperature: 10 °C

Roughness: 0.0070 mm Density: 999.6 kg/m³ Viscosity: 1.297 x 10⁻⁶ m²/s

V̇		Di- men- sion	20.0 mm	25.0 mm	32.0 mm	40.0 mm	50.0 mm	63.0 mm	75.0 mm	90.0 mm	110.0 mm	125.0 mm	160.0 mm	200.0 mm	250.0 mm
0.90 l/s	54.0 l/min	R	129.49	42.10	12.55	4.38	1.50	0.50	0.21	0.09	0.03	0.02	0.01	0.00	0.00
		v	4.37	2.75	1.67	1.08	0.69	0.43	0.30	0.21	0.14	0.11	0.07	0.04	0.03
1.00 l/s	60.0 l/min	R	157.05	50.96	15.16	5.29	1.80	0.60	0.26	0.11	0.04	0.02	0.01	0.00	0.00
		v	4.85	3.06	1.85	1.20	0.76	0.48	0.34	0.24	0.16	0.12	0.07	0.05	0.03
1.20 l/s	72.0 l/min	R	219.61	71.00	21.05	7.33	2.49	0.82	0.35	0.15	0.06	0.03	0.00	0.00	0.00
		v	5.82	3.67	2.23	1.44	0.92	0.58	0.41	0.28	0.19	0.15	0.09	0.06	0.04
1.40 l/s	84.0 l/min	R	292.00	94.09	27.81	9.66	3.28	1.08	0.46	0.20	0.07	0.04	0.01	0.00	0.00
		v	6.79	4.28	2.60	1.68	1.07	0.67	0.47	0.33	0.22	0.17	0.10	0.07	0.04
1.60 l/s	96.0 l/min	R	374.15	120.20	35.43	12.28	4.16	1.37	0.59	0.25	0.09	0.05	0.02	0.01	0.00
		v	7.76	4.90	2.97	1.92	1.22	0.77	0.54	0.38	0.25	0.20	0.12	0.08	0.05
1.80 l/s	108 l/min	R	465.98	149.30	43.89	15.19	5.14	1.69	0.72	0.30	0.12	0.06	0.02	0.01	0.00
		v	8.73	5.51	3.34	2.16	1.38	0.87	0.61	0.42	0.28	0.22	0.13	0.09	0.05
2.00 l/s	120 l/min	R	567.44	181.36	53.20	18.38	6.21	2.04	0.87	0.37	0.14	0.08	0.02	0.01	0.00
		v	9.70	6.12	3.71	2.40	1.53	0.96	0.68	0.47	0.31	0.24	0.15	0.10	0.06
2.20 l/s	132 l/min	R	678.50	216.37	63.33	21.84	7.37	2.42	1.03	0.43	0.17	0.09	0.03	0.00	0.00
		v	10.67	6.73	4.08	2.64	1.68	1.06	0.74	0.52	0.35	0.27	0.16	0.10	0.07
2.40 l/s	144 l/min	R	799.13	254.31	74.29	25.58	8.62	2.83	1.20	0.51	0.19	0.11	0.03	0.01	0.00
		v	11.64	7.34	4.45	2.88	1.84	1.16	0.81	0.56	0.38	0.29	0.18	0.11	0.07
2.60 l/s	156 l/min	R	929.29	295.16	86.06	29.59	9.96	3.27	1.39	0.58	0.22	0.12	0.04	0.01	0.00
		v	12.61	7.95	4.82	3.11	1.99	1.25	0.88	0.61	0.41	0.32	0.19	0.12	0.08
2.80 l/s	168 l/min	R	1068.98	338.93	98.64	33.88	11.39	3.73	1.59	0.66	0.25	0.14	0.04	0.01	0.01
		v	13.58	8.57	5.19	3.35	2.14	1.35	0.95	0.66	0.44	0.34	0.21	0.13	0.09
3.00 l/s	180 l/min	R	1218.17	385.58	112.04	38.43	12.91	4.23	1.80	0.75	0.29	0.16	0.05	0.02	0.01
		v	14.55	9.18	5.56	3.59	2.29	1.45	1.01	0.71	0.47	0.37	0.22	0.14	0.09
3.20 l/s	192 l/min	R	1376.85	435.13	126.23	43.25	14.51	4.75	2.02	0.84	0.32	0.18	0.05	0.02	0.01
		v	15.52	9.79	5.94	3.83	2.45	1.54	1.08	0.75	0.50	0.39	0.24	0.15	0.10
3.40 l/s	204 l/min	R	1545.00	487.56	141.23	48.33	16.20	5.29	2.25	0.94	0.36	0.20	0.06	0.02	0.01
		v	16.50	10.40	6.31	4.07	2.60	1.64	1.15	0.80	0.53	0.41	0.25	0.16	0.10
3.60 l/s	216 l/min	R	1722.64	542.87	157.03	53.67	17.97	5.87	2.49	1.04	0.40	0.22	0.07	0.02	0.01
		v	17.47	11.01	6.68	4.31	2.75	1.73	1.22	0.85	0.57	0.44	0.27	0.17	0.11
3.80 l/s	228 l/min	R	1909.73	601.05	173.62	59.28	19.83	6.47	2.74	1.15	0.44	0.24	0.07	0.03	0.01
		v	18.44	11.63	7.05	4.55	2.91	1.83	1.28	0.89	0.60	0.46	0.28	0.18	0.12
4.00 l/s	240 l/min	R	2106.27	662.09	191.01	65.15	21.78	7.10	3.01	1.26	0.48	0.26	0.08	0.03	0.01
		v	19.41	12.24	7.42	4.79	3.06	1.93	1.35	0.94	0.63	0.49	0.30	0.19	0.12
4.20 l/s	252 l/min	R	2312.26	726.00	209.19	71.28	23.81	7.76	3.28	1.37	0.52	0.28	0.09	0.03	0.01
		v	20.38	12.85	7.79	5.03	3.21	2.02	1.42	0.99	0.66	0.51	0.31	0.20	0.13
4.40 l/s	264 l/min	R	2527.68	792.76	228.15	77.67	25.92	8.44	3.57	1.49	0.57	0.31	0.09	0.03	0.01
		v	21.35	13.46	8.16	5.27	3.37	2.12	1.49	1.03	0.69	0.54	0.33	0.21	0.13
4.60 l/s	276 l/min	R	2752.55	862.38	247.91	84.32	28.12	9.15	3.87	1.62	0.61	0.33	0.10	0.04	0.01
		v	22.32	14.07	8.53	5.51	3.52	2.22	1.55	1.08	0.72	0.56	0.34	0.22	0.14

V̇ = Volumetric current [l/s] R = Pressure gradient [mbar/m] v = Flow rate [m/s]

Pipe friction factor R and calculated flow rate \dot{V} in dependence on the volumetric current \dot{V}

climatherm-pipe SDR 11 - climatherm-faser composite pipe SDR 11

Temperature: 10 °C

Roughness: 0.0070 mm Density: 999.6 kg/m³ Viscosity: 1.297 x 10⁻⁶ m²/s

\dot{V}		Di- men- sion	20.0 mm	25.0 mm	32.0 mm	40.0 mm	50.0 mm	63.0 mm	75.0 mm	90.0 mm	110.0 mm	125.0 mm	160.0 mm	200.0 mm	250.0 mm
4.80 l/s	288 l/min	R	2986.84	934.86	268.45	91.23	30.40	9.88	4.18	1.74	0.66	0.36	0.11	0.04	0.01
		v	23.29	14.69	8.90	5.75	3.67	2.31	1.62	1.13	0.75	0.59	0.36	0.23	0.15
5.00 l/s	300 l/min	R	3230.57	1010.18	289.78	98.40	32.76	10.64	4.50	1.88	0.71	0.39	0.12	0.04	0.01
		v	24.26	15.30	9.27	5.99	3.82	2.41	1.69	1.18	0.79	0.61	0.37	0.24	0.15
5.20 l/s	312 l/min	R	3483.71	1088.36	311.89	105.82	35.20	11.43	4.83	2.01	0.76	0.42	0.13	0.04	0.02
		v	25.23	15.91	9.65	6.23	3.98	2.51	1.76	1.22	0.82	0.63	0.39	0.25	0.16
5.40 l/s	324 l/min	R	3746.28	1169.38	334.78	113.49	37.73	12.24	5.17	2.16	0.82	0.44	0.14	0.05	0.02
		v	26.20	16.52	10.02	6.47	4.13	2.60	1.82	1.27	0.85	0.66	0.40	0.26	0.16
5.60 l/s	336 l/min	R	4018.26	1253.24	358.46	121.43	40.34	13.08	5.52	2.30	0.87	0.47	0.15	0.05	0.02
		v	27.17	17.13	10.39	6.71	4.28	2.70	1.89	1.32	0.88	0.68	0.42	0.27	0.17
5.80 l/s	348 l/min	R	4299.66	1339.95	382.92	129.62	43.03	13.95	5.89	2.45	0.93	0.50	0.15	0.05	0.02
		v	28.14	17.75	10.76	6.95	4.44	2.80	1.96	1.36	0.91	0.71	0.43	0.28	0.18
6.00 l/s	360 l/min	R	4590.48	1429.50	408.16	138.06	45.80	14.84	6.26	2.61	0.99	0.54	0.16	0.06	0.02
		v	29.11	18.36	11.13	7.19	4.59	2.89	2.03	1.41	0.94	0.73	0.45	0.29	0.18
6.20 l/s	372 l/min	R	4890.70	1521.88	434.17	146.76	48.65	15.75	6.64	2.76	1.05	0.57	0.17	0.06	0.02
		v	30.08	18.97	11.50	7.43	4.74	2.99	2.09	1.46	0.97	0.76	0.46	0.29	0.19
6.40 l/s	384 l/min	R	5200.34	1617.11	460.97	155.71	51.59	16.69	7.04	2.93	1.11	0.60	0.18	0.06	0.02
		v	31.05	19.58	11.87	7.67	4.90	3.08	2.16	1.50	1.01	0.78	0.48	0.30	0.19
6.60 l/s	396 l/min	R	5519.38	1715.17	488.54	164.91	54.61	17.66	7.44	3.01	1.17	0.64	0.19	0.07	0.02
		v	32.02	20.19	12.24	7.91	5.05	3.18	2.23	1.55	1.04	0.80	0.49	0.31	0.20
6.80 l/s	408 l/min	R	5847.83	1816.07	516.89	174.37	57.70	18.65	7.86	3.27	1.24	0.67	0.21	0.07	0.02
		v	32.99	20.80	12.61	8.15	5.20	3.28	2.30	1.60	1.07	0.83	0.51	0.32	0.21
7.00 l/s	420 l/min	R	6185.68	1919.80	546.02	184.08	60.88	19.67	8.28	3.44	1.30	0.71	0.22	0.07	0.03
		v	33.96	21.42	12.98	8.39	5.35	3.37	2.36	1.65	1.10	0.85	0.52	0.33	0.21
7.50 l/s	450 l/min	R	7071.45	2191.54	622.22	209.45	69.17	22.32	9.39	3.90	1.48	0.80	0.24	0.08	0.03
		v	36.39	22.95	13.91	8.99	5.74	3.61	2.53	1.76	1.18	0.91	0.56	0.36	0.23
8.00 l/s	480 l/min	R	8015.98	2480.97	703.27	236.40	77.97	25.12	10.57	4.39	1.66	0.90	0.27	0.09	0.03
		v	38.81	24.48	14.84	9.58	6.12	3.86	2.70	1.88	1.26	0.98	0.60	0.38	0.24
9.00 l/s	540 l/min	R	10081.26	3112.89	879.88	295.00	97.06	31.21	13.10	5.43	2.05	1.11	0.34	0.12	0.04
		v	43.66	27.54	16.69	10.78	6.88	4.34	3.04	2.12	1.41	1.01	0.67	0.43	0.27
10.0 l/s	600 l/min	R		3815.51	1075.77	359.86	118.13	37.90	15.89	6.58	2.48	1.34	0.41	0.14	0.05
		v		30.59	18.55	11.98	7.65	4.82	3.38	2.35	1.57	1.22	0.74	0.48	0.30
12.0 l/s	720 l/min	R		5432.66	1525.35	508.25	166.18	53.12	22.22	9.18	3.46	1.87	0.57	0.19	0.07
		v		36.71	22.26	14.38	9.18	5.78	4.05	2.82	1.89	1.46	0.89	0.57	0.36
14.0 l/s	840 l/min	R		7332.17	2051.81	681.46	222.06	70.75	29.53	12.18	4.58	2.47	0.75	0.26	0.09
		v		42.83	25.97	16.77	10.71	6.75	4.73	3.29	2.20	1.71	1.04	0.67	0.43
16.0 l/s	960 l/min	R			2655.06	879.40	285.72	90.78	37.81	15.56	5.84	3.15	0.96	0.33	0.11
		v			29.68	19.17	12.24	7.71	5.40	3.76	2.52	1.95	1.19	0.76	0.49
18.0 l/s	1080 l/min	R			3335.00	1102.03	357.14	113.18	47.05	19.34	7.24	3.91	1.18	0.40	0.14
		v			33.39	21.56	13.77	8.67	6.08	4.23	2.83	2.19	1.34	0.86	0.55

\dot{V} = Volumetric current [l/s]

R = Pressure gradient [mbar/m]

v = Flow rate [m/s]

Pipe friction factor R and calculated flow rate v in dependence on the volumetric current V̇

climatherm-pipe SDR 11 - **climatherm**-faser composite pipe SDR 11

Temperature: 10 °C

Roughness: 0.0070 mm Density: 999.6 kg/m³ Viscosity: 1.297 x 10⁻⁶ m²/s

V̇		Di- men- sion	20.0 mm	25.0 mm	32.0 mm	40.0 mm	50.0 mm	63.0 mm	75.0 mm	90.0 mm	110.0 mm	125.0 mm	160.0 mm	200.0 mm	250.0 mm
20.0 l/s	1200 l/min	R			4091.62	1349.31	436.29	137.94	57.25	23.49	8.79	4.73	1.43	0.49	0.17
	v	v			37.01	23.96	15.30	9.64	6.75	4.70	3.14	2.44	1.49	0.95	0.61
22.0 l/s	1320 l/min	R			4924.85	1621.21	523.16	165.05	68.40	28.03	10.47	5.64	1.70	0.58	0.20
	v	v			40.81	26.36	16.83	10.60	7.43	5.17	3.46	2.68	1.64	1.05	0.67
24.0 l/s	1440 l/min	R			5834.68	1917.72	617.72	194.51	80.50	32.94	12.29	6.61	1.99	0.68	0.23
	v	v			44.52	28.75	18.36	11.57	8.11	5.64	3.77	2.93	1.79	1.14	0.73
26.0 l/s	1560 l/min	R				2238.81	719.97	226.31	93.53	38.23	14.25	7.66	2.31	0.78	0.27
	v	v				31.15	19.89	12.53	8.78	6.11	4.09	3.17	1.93	1.24	0.79
28.0 l/s	1680 l/min	R				2584.48	829.91	260.45	107.51	43.89	16.34	8.78	2.64	0.89	0.30
	v	v				33.55	21.42	13.49	9.46	6.58	4.40	3.41	2.08	1.33	0.85
30.0 l/s	1800 l/min	R				2954.71	947.51	296.91	122.42	49.92	18.56	9.97	3.00	1.01	0.34
	v	v				35.94	22.95	14.46	10.13	7.05	4.72	3.66	2.23	1.43	0.91
32.0 l/s	1920 l/min	R				3349.50	1072.78	335.70	138.26	56.32	20.92	11.23	3.37	1.14	0.39
	v	v				38.34	24.48	15.42	10.81	7.52	5.03	3.90	2.38	1.52	0.97
34.0 l/s	2040 l/min	R				3768.84	1205.72	376.81	155.04	63.09	23.41	12.56	3.77	1.27	0.43
	v	v				40.73	26.01	16.39	11.48	7.99	5.34	4.14	2.53	1.62	1.03
36.0 l/s	2160 l/min	R				4212.72	1346.31	420.24	172.74	70.23	26.04	13.96	4.19	1.41	0.48
	v	v				43.13	27.54	17.35	12.16	8.46	5.66	4.39	2.68	1.71	1.09
38.0 l/s	2280 l/min	R					1494.56	465.98	191.38	77.73	28.80	15.43	4.62	1.56	0.53
	v	v					29.07	18.31	12.83	8.93	5.97	4.63	2.83	1.81	1.16
40.0 l/s	2400 l/min	R					1650.46	514.04	210.93	85.61	31.68	16.96	5.08	1.71	0.58
	v	v					30.59	19.28	13.51	9.40	6.29	4.88	2.98	1.90	1.22
42.0 l/s	2520 l/min	R					1814.01	564.42	231.42	93.84	34.70	18.57	5.56	1.87	0.63
	v	v					32.12	20.24	14.18	9.87	6.60	5.12	3.13	2.00	1.28
44.0 l/s	2640 l/min	R					1985.20	617.10	252.83	102.45	37.85	20.25	6.05	2.04	0.69
	v	v					33.65	21.20	14.86	10.34	6.92	5.36	3.27	2.09	1.34
46.0 l/s	2760 l/min	R					2164.04	672.10	275.16	111.41	41.14	21.99	6.57	2.21	0.75
	v	v					35.18	22.17	15.54	10.81	7.23	5.61	3.42	2.19	1.40
48.0 l/s	2880 l/min	R					2350.52	729.41	298.41	120.74	44.55	23.81	7.11	2.39	0.81
	v	v					36.71	23.13	16.21	11.28	7.55	5.85	3.57	2.28	1.46
50.0 l/s	3000 l/min	R					2544.65	789.02	322.59	130.43	48.09	25.69	7.66	2.57	0.87
	v	v					38.24	24.01	16.89	11.75	7.86	6.01	3.72	2.38	1.52
52.0 l/s	3120 l/min	R					2746.41	850.94	347.68	140.49	51.76	27.64	8.24	2.77	0.93
	v	v					39.77	25.06	17.56	12.22	8.17	6.34	3.87	2.47	1.58
54.0 l/s	3240 l/min	R					2955.82	915.17	373.70	150.91	55.56	29.66	8.83	2.97	1.00
	v	v					41.30	26.02	18.24	12.69	8.49	6.58	4.02	2.57	1.64
56.0 l/s	3360 l/min	R					3172.86	981.70	400.63	161.68	59.49	31.74	9.45	3.17	1.07
	v	v					42.83	26.99	18.91	13.16	8.80	6.83	4.17	2.66	1.70
58.0 l/s	3480 l/min	R					3397.54	1050.54	428.49	172.82	63.55	33.90	10.08	3.38	1.14
	v	v					44.36	27.95	19.59	13.63	9.12	7.07	4.32	2.76	1.76

V̇ = Volumetric current [l/s] R = Pressure gradient [mbar/m] v = Flow rate [m/s]

Pipe friction factor R and calculated flow rate v in dependence on the volumetric current \dot{V}

climatherm-pipe SDR 11 - **climatherm**-faser composite pipe SDR 11

Temperature: 10 °C

Roughness: 0.0070 mm Density: 999.6 kg/m³ Viscosity: 1.297 x 10⁻⁶ m²/s

\dot{V}		Di- men- sion	20.0 mm	25.0 mm	32.0 mm	40.0 mm	50.0 mm	63.0 mm	75.0 mm	90.0 mm	110.0 mm	125.0 mm	160.0 mm	200.0 mm	250.0 mm
60.0 l/s	3600 l/min	R						1121.68	457.26	184.33	67.74	36.12	10.74	3.60	1.21
		v						28.92	20.26	14.10	9.43	7.31	4.47	2.85	1.82
62.0 l/s	3720 l/min	R						1195.13	486.95	196.19	72.05	38.40	11.41	3.82	1.29
		v						29.88	20.94	14.57	9.75	7.56	4.61	2.95	1.89
64.0 l/s	3840 l/min	R						1270.88	517.56	208.41	76.50	40.76	12.10	4.05	1.37
		v						30.84	21.61	15.04	10.06	7.80	4.76	3.04	1.95
66.0 l/s	3960 l/min	R						1348.93	549.09	220.99	81.07	43.18	12.81	4.29	1.44
		v						31.81	22.29	15.51	10.37	8.05	4.91	3.14	2.01
68.0 l/s	4080 l/min	R						1429.28	581.54	233.94	85.77	45.67	13.54	4.53	1.53
		v						32.77	22.97	15.98	10.69	8.29	5.06	3.23	2.07
70.0 l/s	4200 l/min	R						1511.94	614.90	247.24	90.60	48.23	14.29	4.78	1.61
		v						33.74	23.64	16.45	11.00	8.53	5.21	3.33	2.13
72.0 l/s	4320 l/min	R						1596.90	649.18	260.90	95.56	50.85	15.06	5.04	1.69
		v						34.70	24.32	16.92	11.32	8.78	5.36	3.43	2.19
74.0 l/s	4440 l/min	R						1684.16	684.37	274.93	100.64	53.54	15.85	5.30	1.78
		v						35.66	24.99	17.39	11.63	9.02	5.51	3.52	2.25
76.0 l/s	4560 l/min	R						1773.72	720.48	289.31	105.86	56.30	16.66	5.57	1.87
		v						36.63	25.67	17.86	11.95	9.26	5.66	3.62	2.31
78.0 l/s	4680 l/min	R						1865.58	757.51	304.05	111.20	59.12	17.49	5.84	1.96
		v						37.59	26.34	18.33	12.26	9.51	5.80	3.71	2.37
80.0 l/s	4800 l/min	R						1959.74	795.45	319.15	116.67	62.01	18.33	6.12	2.06
		v						38.55	27.02	18.80	12.58	9.75	5.95	3.81	2.43
85.0 l/s	5100 l/min	R						2205.20	894.31	358.47	130.90	69.53	20.53	6.85	2.30
		v						40.96	28.71	19.98	13.36	10.36	6.33	4.04	2.59
90.0 l/s	5400 l/min	R						2465.04	998.89	400.03	145.92	77.46	22.84	7.61	2.55
		v						43.37	30.40	21.15	14.15	10.97	6.70	4.28	2.74
95.0 l/s	5700 l/min	R							1109.19	443.83	161.74	85.80	25.27	8.41	2.82
		v							32.08	22.33	14.93	11.58	7.07	4.52	2.89
100.0 l/s	6000 l/min	R							1225.20	489.87	178.35	94.56	27.82	9.25	3.10
		v							33.77	23.50	15.72	12.19	7.44	4.76	3.04
105.0 l/s	6300 l/min	R							1346.92	538.14	195.76	103.73	30.49	10.13	3.39
		v							35.46	24.68	16.50	12.80	7.81	4.99	3.19

\dot{V} = Volumetric current [l/s]

R = Pressure gradient [mbar/m]

v = Flow rate [m/s]

Pipe friction factor R and calculated flow rate v in dependence on the volumetric current V̇

climatherm-pipe SDR 11 - climatherm-faser composite pipe SDR 11

Temperature: 70 °C

Roughness: 0.0070 mm Density: 977.7 kg/m³ Viscosity: 0.41 x 10⁻⁶ m²/s

V̇		Di- men- sion	20.0 mm	25.0 mm	32.0 mm	40.0 mm	50.0 mm	63.0 mm	75.0 mm	90.0 mm	110.0 mm	125.0 mm	160.0 mm	200.0 mm	250.0 mm
0.01 l/s	0.60 l/min	R	0.04	0.01	0.00	0.00	0.00	0.00	0.00	0.00	0.00	0.00	0.00	0.00	0.00
		v	0.05	0.03	0.02	0.01	0.01	0.01	0.00	0.00	0.00	0.00	0.00	0.00	0.00
0.02 l/s	1.20 l/min	R	0.12	0.04	0.01	0.00	0.00	0.00	0.00	0.00	0.00	0.00	0.00	0.00	0.00
		v	0.01	0.06	0.04	0.02	0.02	0.00	0.01	0.01	0.00	0.00	0.00	0.00	0.00
0.03 l/s	1.80 l/min	R	0.23	0.08	0.02	0.01	0.00	0.00	0.00	0.00	0.00	0.00	0.00	0.00	0.00
		v	0.15	0.09	0.06	0.04	0.02	0.01	0.01	0.01	0.01	0.01	0.00	0.00	0.00
0.04 l/s	2.40 l/min	R	0.38	0.13	0.04	0.01	0.01	0.00	0.00	0.00	0.00	0.00	0.00	0.00	0.00
		v	0.19	0.12	0.07	0.05	0.03	0.02	0.01	0.01	0.01	0.01	0.01	0.00	0.00
0.05 l/s	3.00 l/min	R	0.57	0.19	0.06	0.02	0.01	0.00	0.00	0.00	0.00	0.00	0.00	0.00	0.00
		v	0.24	0.15	0.09	0.06	0.04	0.02	0.02	0.02	0.01	0.01	0.01	0.00	0.00
0.06 l/s	3.60 l/min	R	0.78	0.26	0.08	0.03	0.00	0.00	0.00	0.00	0.00	0.00	0.00	0.00	0.00
		v	0.29	0.18	0.11	0.07	0.05	0.03	0.02	0.01	0.01	0.01	0.01	0.00	0.00
0.07 l/s	4.20 l/min	R	1.02	0.34	0.10	0.04	0.01	0.00	0.00	0.00	0.00	0.00	0.00	0.00	0.00
		v	0.34	0.21	0.13	0.08	0.05	0.03	0.02	0.02	0.02	0.01	0.01	0.01	0.00
0.08 l/s	4.80 l/min	R	1.30	0.43	0.13	0.05	0.02	0.01	0.00	0.00	0.00	0.00	0.00	0.00	0.00
		v	0.39	0.24	0.15	0.01	0.06	0.04	0.03	0.02	0.02	0.01	0.00	0.01	0.00
0.09 l/s	5.40 l/min	R	1.60	0.53	0.16	0.06	0.02	0.01	0.00	0.00	0.00	0.00	0.00	0.00	0.00
		v	0.44	0.28	0.17	0.11	0.07	0.04	0.03	0.02	0.02	0.01	0.01	0.01	0.00
0.10 l/s	6.00 l/min	R	1.92	0.64	0.19	0.07	0.02	0.01	0.00	0.00	0.00	0.00	0.00	0.00	0.00
		v	0.49	0.31	0.19	0.12	0.08	0.05	0.03	0.02	0.02	0.02	0.01	0.01	0.01
0.12 l/s	7.20 l/min	R	2.66	0.88	0.27	0.09	0.03	0.01	0.01	0.00	0.00	0.00	0.00	0.00	0.00
		v	0.58	0.37	0.22	0.14	0.09	0.06	0.04	0.03	0.03	0.02	0.01	0.01	0.01
0.16 l/s	9.60 l/min	R	4.46	1.47	0.44	0.16	0.05	0.02	0.01	0.00	0.00	0.00	0.00	0.00	0.00
		v	0.78	0.49	0.30	0.19	0.12	0.08	0.05	0.04	0.03	0.03	0.02	0.01	0.01
0.18 l/s	10.8 l/min	R	5.51	1.81	0.54	0.19	0.07	0.02	0.01	0.00	0.00	0.00	0.00	0.00	0.00
		v	0.87	0.55	0.33	0.22	0.14	0.09	0.06	0.04	0.04	0.03	0.02	0.01	0.01
0.20 l/s	12.0 l/min	R	6.67	2.18	0.65	0.23	0.08	0.03	0.01	0.01	0.00	0.00	0.00	0.00	0.00
		v	0.97	0.61	0.37	0.24	0.15	0.01	0.07	0.05	0.03	0.03	0.02	0.01	0.00
0.30 l/s	18.0 l/min	R	13.96	4.53	1.35	0.47	0.16	0.05	0.02	0.00	0.00	0.00	0.00	0.00	0.00
		v	1.46	0.92	0.56	0.36	0.23	0.14	0.10	0.07	0.07	0.05	0.04	0.02	0.01
0.40 l/s	24.0 l/min	R	23.69	7.65	2.27	0.79	0.27	0.09	0.04	0.02	0.01	0.00	0.00	0.00	0.00
		v	1.94	1.22	0.74	0.48	0.31	0.19	0.14	0.09	0.09	0.06	0.05	0.03	0.02
0.50 l/s	30.0 l/min	R	35.82	11.51	3.39	1.18	0.40	0.13	0.06	0.02	0.01	0.01	0.00	0.00	0.00
		v	2.43	1.53	0.93	0.60	0.38	0.24	0.17	0.12	0.12	0.08	0.06	0.04	0.02
0.60 l/s	36.0 l/min	R	50.32	16.10	4.73	1.64	0.55	0.18	0.08	0.03	0.01	0.01	0.00	0.00	0.00
		v	2.91	1.84	1.11	0.72	0.46	0.29	0.20	0.14	0.14	0.09	0.07	0.04	0.03
0.70 l/s	42.0 l/min	R	67.17	21.42	6.27	2.16	0.73	0.24	0.10	0.04	0.02	0.01	0.00	0.00	0.00
		v	3.40	2.14	1.30	0.84	0.54	0.34	0.24	0.16	0.16	0.11	0.09	0.05	0.03
0.80 l/s	48.0 l/min	R	86.36	27.45	8.01	2.76	0.93	0.30	0.13	0.05	0.02	0.01	0.00	0.00	0.00
		v	3.88	2.45	1.48	0.96	0.61	0.39	0.27	0.19	0.13	0.13	0.01	0.06	0.04

V̇ = Volumetric current [l/s] R = Pressure gradient [mbar/m] v = Flow rate [m/s]

Pipe friction factor R and calculated flow rate v in dependence on the volumetric current \dot{V}

climatherm-pipe SDR 11 - climatherm-faser composite pipe SDR 11

Temperature: 70 °C

Roughness: 0.0070 mm Density: 977.7 kg/m³ Viscosity: 0.41 x 10⁻⁶ m²/s

\dot{V}		Di- men- sion	20.0 mm	25.0 mm	32.0 mm	40.0 mm	50.0 mm	63.0 mm	75.0 mm	90.0 mm	110.0 mm	125.0 mm	160.0 mm	200.0 mm	250.0 mm
0.90 l/s	54.0 l/min	R	107.89	34.20	9.95	3.42	1.15	0.38	0.16	0.07	0.03	0.01	0.00	0.00	0.00
		v	4.37	2.75	1.67	1.08	0.69	0.43	0.30	0.21	0.14	0.11	0.07	0.04	0.03
1.00 l/s	60.0 l/min	R	131.73	41.65	12.09	4.14	1.39	0.45	0.19	0.08	0.03	0.02	0.01	0.00	0.00
		v	4.85	3.06	1.85	1.20	0.76	0.48	0.34	0.24	0.16	0.12	0.07	0.05	0.03
1.20 l/s	72.0 l/min	R	186.37	58.66	16.95	5.79	1.94	0.63	0.27	0.11	0.04	0.02	0.01	0.00	0.00
		v	5.82	3.67	2.23	1.44	0.92	0.58	0.41	0.28	0.19	0.15	0.09	0.06	0.04
1.40 l/s	84.0 l/min	R	250.26	78.49	22.59	7.69	2.57	0.84	0.35	0.15	0.06	0.03	0.01	0.00	0.00
		v	6.79	4.28	2.60	1.68	1.07	0.67	0.47	0.33	0.22	0.17	0.10	0.07	0.04
1.60 l/s	96.0 l/min	R	323.38	101.10	29.00	9.84	3.28	1.06	0.45	0.19	0.07	0.04	0.01	0.00	0.00
		v	7.76	4.90	2.97	1.92	1.22	0.77	0.54	0.38	0.25	0.20	0.12	0.08	0.05
1.80 l/s	108 l/min	R	405.71	126.50	36.17	12.25	4.07	1.32	0.56	0.23	0.09	0.05	0.01	0.01	0.00
		v	8.73	5.51	3.34	2.16	1.38	0.87	0.61	0.42	0.28	0.22	0.13	0.09	0.05
2.00 l/s	120 l/min	R	497.26	154.68	44.11	14.91	4.94	1.60	0.67	0.28	0.11	0.06	0.02	0.01	0.00
		v	9.70	6.12	3.71	2.40	1.53	0.96	0.68	0.47	0.31	0.24	0.15	0.01	0.06
2.20 l/s	132 l/min	R	598.00	185.64	52.81	17.81	5.89	1.90	0.80	0.33	0.13	0.07	0.02	0.01	0.00
		v	10.67	6.73	4.08	2.64	1.68	1.06	0.74	0.52	0.35	0.27	0.16	0.10	0.07
2.40 l/s	144 l/min	R	707.95	219.37	62.27	20.96	6.92	2.23	0.94	0.39	0.15	0.08	0.02	0.01	0.00
		v	11.64	7.34	4.45	2.88	1.84	1.16	0.81	0.56	0.38	0.29	0.18	0.11	0.07
2.60 l/s	156 l/min	R	827.09	255.87	72.49	24.36	8.03	2.59	1.09	0.45	0.17	0.09	0.03	0.00	0.00
		v	12.61	7.95	4.82	3.11	1.99	1.25	0.88	0.61	0.41	0.32	0.19	0.12	0.08
2.80 l/s	168 l/min	R	955.42	295.13	83.46	28.00	9.21	2.96	1.24	0.52	0.20	0.11	0.03	0.01	0.00
		v	13.58	8.57	5.19	3.35	2.14	1.35	0.95	0.66	0.44	0.34	0.21	0.13	0.09
3.00 l/s	180 l/min	R	1092.94	337.17	95.19	31.88	10.48	3.37	1.41	0.59	0.22	0.12	0.04	0.01	0.00
		v	14.55	9.18	5.56	3.59	2.29	1.45	1.01	0.71	0.47	0.37	0.22	0.14	0.09
3.20 l/s	192 l/min	R	1239.65	381.96	107.68	36.01	11.82	3.79	1.59	0.66	0.25	0.13	0.04	0.01	0.01
		v	15.52	9.79	5.94	3.83	2.45	1.54	1.08	0.75	0.50	0.39	0.24	0.15	0.01
3.40 l/s	204 l/min	R	1395.55	429.53	120.91	40.39	13.24	4.24	1.78	0.74	0.28	0.15	0.05	0.02	0.01
		v	16.50	10.40	6.31	4.07	2.60	1.64	1.15	0.80	0.53	0.41	0.25	0.16	0.10
3.60 l/s	216 l/min	R	1560.63	479.85	134.90	45.01	14.73	4.72	1.97	0.82	0.31	0.17	0.05	0.02	0.01
		v	17.47	11.01	6.68	4.31	2.75	1.73	1.22	0.85	0.57	0.44	0.27	0.17	0.11
3.80 l/s	228 l/min	R	1734.90	532.94	149.64	49.87	16.31	5.21	2.18	0.90	0.34	0.18	0.06	0.02	0.01
		v	18.44	11.63	7.05	4.55	2.91	1.83	1.28	0.89	0.60	0.46	0.28	0.18	0.12
4.00 l/s	240 l/min	R	1918.35	588.78	165.14	54.97	17.95	5.73	2.40	0.99	0.37	0.20	0.06	0.02	0.01
		v	19.41	12.24	7.42	4.79	3.06	1.93	1.35	0.94	0.63	0.49	0.30	0.19	0.12
4.20 l/s	252 l/min	R	2110.99	647.39	181.39	60.31	19.68	6.28	2.62	1.08	0.41	0.22	0.07	0.02	0.01
		v	20.38	12.85	7.79	5.03	3.21	2.02	1.42	0.99	0.66	0.51	0.31	0.20	0.13
4.40 l/s	264 l/min	R	2312.81	708.76	198.38	65.90	21.48	6.85	2.86	1.18	0.44	0.24	0.07	0.02	0.01
		v	21.35	13.46	8.16	5.27	3.37	2.12	1.49	1.03	0.69	0.54	0.33	0.21	0.13
4.60 l/s	276 l/min	R	2523.82	772.89	216.13	71.73	23.36	7.44	3.10	1.28	0.48	0.26	0.08	0.03	0.01
		v	22.32	14.07	8.53	5.51	3.52	2.22	1.55	1.08	0.72	0.56	0.34	0.22	0.14

\dot{V} = Volumetric current [l/s]

R = Pressure gradient [mbar/m]

v = Flow rate [m/s]

Pipe friction factor R and calculated flow rate v in dependence on the volumetric current V̇

climatherm-pipe SDR 11 - **climatherm**-faser composite pipe SDR 11

Temperature: 70 °C

Roughness: 0.0070 mm Density: 977.7 kg/m³ Viscosity: 0.41 x 10⁶ m²/s

V̇		Di- men- sion	20.0 mm	25.0 mm	32.0 mm	40.0 mm	50.0 mm	63.0 mm	75.0 mm	90.0 mm	110.0 mm	125.0 mm	160.0 mm	200.0 mm	250.0 mm
4.80 l/s	288 l/min	R	2744.01	839.79	234.63	77.80	25.31	8.05	3.36	1.38	0.52	0.28	0.09	0.03	0.00
		v	23.29	14.69	8.90	5.75	3.67	2.31	1.62	1.13	0.75	0.59	0.36	0.23	0.15
5.00 l/s	300 l/min	R	2973.38	909.44	253.88	84.12	27.34	8.69	3.62	1.49	0.56	0.30	0.09	0.03	0.01
		v	24.26	15.30	9.27	5.99	3.82	2.41	1.69	1.18	0.79	0.61	0.37	0.24	0.15
5.20 l/s	312 l/min	R	3211.93	981.84	273.88	90.67	29.45	9.35	3.89	1.60	0.60	0.32	0.01	0.03	0.01
		v	25.23	15.91	9.65	6.23	3.98	2.51	1.76	1.22	0.82	0.63	0.39	0.25	0.16
5.40 l/s	324 l/min	R	3459.66	1057.01	294.63	97.47	31.63	10.03	4.18	1.72	0.64	0.35	0.11	0.04	0.01
		v	26.20	16.52	10.02	6.47	4.13	2.60	1.82	1.27	0.85	0.66	0.40	0.26	0.16
5.60 l/s	336 l/min	R	3716.58	1134.94	316.13	104.51	33.88	10.74	4.47	1.84	0.69	0.37	0.11	0.04	0.01
		v	27.17	17.13	10.39	6.71	4.28	2.70	1.89	1.32	0.88	0.68	0.42	0.27	0.17
5.80 l/s	348 l/min	R	3982.68	1215.63	338.38	111.78	36.22	11.47	4.77	1.96	0.73	0.40	0.12	0.04	0.01
		v	28.14	17.75	10.76	6.95	4.44	2.80	1.96	1.36	0.91	0.71	0.43	0.28	0.18
6.00 l/s	360 l/min	R	4257.95	1299.07	361.38	119.30	38.62	12.23	5.08	2.09	0.78	0.42	0.13	0.04	0.01
		v	29.11	18.36	11.13	7.19	4.59	2.89	2.03	1.41	0.94	0.73	0.45	0.29	0.18
6.20 l/s	372 l/min	R	4542.41	1385.28	385.13	127.07	41.11	13.00	5.40	2.22	0.83	0.45	0.14	0.05	0.02
		v	30.08	18.97	11.50	7.43	4.74	2.99	2.09	1.46	0.97	0.76	0.46	0.29	0.19
6.40 l/s	384 l/min	R	4836.06	1474.24	409.63	135.07	43.67	13.80	5.73	2.35	0.88	0.47	0.14	0.05	0.02
		v	31.05	19.58	11.87	7.67	4.90	3.08	2.16	1.50	1.01	0.78	0.48	0.30	0.19
6.60 l/s	396 l/min	R	5138.88	1565.96	434.88	143.31	46.30	14.63	6.07	2.49	0.93	0.50	0.15	0.05	0.02
		v	32.02	20.19	12.24	7.91	5.05	3.18	2.23	1.55	1.04	0.80	0.49	0.31	0.20
6.80 l/s	408 l/min	R	5450.88	1660.44	460.88	151.79	49.01	15.47	6.41	2.63	0.98	0.53	0.16	0.05	0.02
		v	32.99	20.80	12.61	8.15	5.20	3.28	2.30	1.60	1.07	0.83	0.51	0.32	0.21
7.00 l/s	420 l/min	R	5772.06	1757.67	487.62	160.52	51.80	16.34	6.77	2.77	1.04	0.56	0.17	0.06	0.02
		v	33.96	21.42	12.98	8.39	5.35	3.37	2.36	1.65	1.10	0.85	0.52	0.33	0.21
7.50 l/s	450 l/min	R	6615.19	2012.83	557.77	183.38	59.09	18.61	7.70	3.15	1.18	0.63	0.19	0.06	0.02
		v	36.39	22.95	13.91	8.99	5.74	3.61	2.53	1.76	1.18	0.91	0.56	0.36	0.23
8.00 l/s	480 l/min	R	7515.69	2285.22	632.60	207.74	66.85	21.03	8.70	3.56	1.33	0.71	0.21	0.07	0.02
		v	38.81	24.48	14.84	9.58	6.12	3.86	2.70	1.88	1.26	0.98	0.60	0.38	0.24
9.00 l/s	540 l/min	R	9488.83	2881.71	796.29	260.98	83.78	26.29	10.85	4.43	1.65	0.89	0.27	0.09	0.03
		v	43.66	27.54	16.69	10.78	6.88	4.34	3.04	2.12	1.41	1.01	0.67	0.43	0.27
10.0 l/s	600 l/min	R		3547.14	978.70	320.23	102.59	32.12	13.23	5.39	2.00	1.07	0.32	0.11	0.04
		v		30.59	18.55	11.98	7.65	4.82	3.38	2.35	1.57	1.22	0.74	0.48	0.30
12.0 l/s	720 l/min	R		5084.80	1399.66	456.72	145.83	45.47	18.68	7.59	2.81	1.51	0.45	0.15	0.05
		v		36.71	22.26	14.38	9.18	5.78	4.05	2.82	1.89	1.46	0.89	0.57	0.36
14.0 l/s	840 l/min	R		6898.17	1895.46	617.22	196.56	61.01	25.03	10.14	3.75	2.01	0.60	0.20	0.07
		v		42.83	25.97	16.77	10.71	6.75	4.73	3.29	2.20	1.71	1.04	0.67	0.43
16.0 l/s	960 l/min	R			2466.10	801.71	254.76	78.98	32.29	13.05	4.81	2.57	0.77	0.26	0.09
		v			29.68	19.17	12.24	7.71	5.40	3.76	2.52	1.95	1.19	0.76	0.49
18.0 l/s	1080 l/min	R			3111.56	1010.18	320.43	99.12	40.44	16.32	6.00	3.20	0.95	0.32	0.11
		v			33.39	21.56	13.77	8.67	6.08	4.23	2.83	2.19	1.34	0.86	0.55

V̇ = Volumetric current [l/s] R = Pressure gradient [mbar/m] v = Flow rate [m/s]

Pipe friction factor R and calculated flow rate \dot{v} in dependence on the volumetric current \dot{V}

climatherm-pipe SDR 11 - **climatherm**-faser composite pipe SDR 11

Temperature: 70 °C

Roughness: 0.0070 mm Density: 977.7 kg/m³ Viscosity: 0.41 x 10⁶ m²/s

\dot{V}		Di- men- sion	20.0 mm	25.0 mm	32.0 mm	40.0 mm	50.0 mm	63.0 mm	75.0 mm	90.0 mm	110.0 mm	125.0 mm	160.0 mm	200.0 mm	250.0 mm
20.0 l/s	1200 l/min	R			3831.85	1242.64	393.58	121.52	49.50	19.94	7.32	3.90	1.16	0.39	0.13
	v	v			37.01	23.96	15.30	9.64	6.75	4.70	3.14	2.44	1.49	0.95	0.61
22.0 l/s	1320 l/min	R			4626.95	1499.08	474.19	146.16	59.45	23.91	8.76	4.67	1.38	0.46	0.16
	v	v			40.81	26.36	16.83	10.60	7.43	5.17	3.46	2.68	1.64	1.05	0.67
24.0 l/s	1440 l/min	R			5496.87	1779.50	562.27	173.06	70.30	28.23	10.33	5.49	1.63	0.54	0.18
	v	v			44.52	28.75	18.36	11.57	8.11	5.64	3.77	2.93	1.79	1.14	0.73
26.0 l/s	1560 l/min	R				2083.89	657.81	202.21	82.05	32.91	12.02	6.39	1.89	0.63	0.21
	v	v				31.15	19.89	12.53	8.78	6.11	4.09	3.17	1.93	1.24	0.79
28.0 l/s	1680 l/min	R				2412.26	760.82	233.61	94.69	37.93	13.84	7.35	2.17	0.72	0.24
	v	v				33.55	21.42	13.49	9.46	6.58	4.40	3.41	2.08	1.33	0.85
30.0 l/s	1800 l/min	R				2764.61	871.29	267.26	108.23	43.31	15.78	8.37	2.47	0.82	0.28
	v	v				35.94	22.95	14.46	10.13	7.05	4.72	3.66	2.23	1.43	0.91
32.0 l/s	1920 l/min	R				3140.93	989.23	303.15	122.66	49.04	17.85	9.46	2.78	0.93	0.31
	v	v				38.34	24.48	15.42	10.81	7.52	5.03	3.90	2.38	1.52	0.97
34.0 l/s	2040 l/min	R				3541.23	1114.63	341.30	137.98	55.11	20.04	10.62	3.12	1.04	0.35
	v	v				40.73	26.01	16.39	11.48	7.99	5.34	4.14	2.53	1.62	1.03
36.0 l/s	2160 l/min	R				3965.50	1247.49	381.69	154.20	61.54	22.36	11.84	3.47	1.15	0.39
	v	v				43.13	27.54	17.35	12.16	8.46	5.66	4.39	2.68	1.71	1.09
38.0 l/s	2280 l/min	R					1387.81	424.33	171.31	68.32	24.79	13.12	3.85	1.28	0.43
	v	v					29.07	18.31	12.83	8.93	5.97	4.63	2.83	1.81	1.16
40.0 l/s	2400 l/min	R					1535.59	469.21	189.32	75.44	27.36	14.47	4.24	1.40	0.47
	v	v					30.59	19.28	13.51	9.40	6.29	4.88	2.98	1.90	1.22
42.0 l/s	2520 l/min	R					1690.84	516.35	208.22	82.91	30.04	15.88	4.64	1.54	0.51
	v	v					32.12	20.24	14.18	9.87	6.60	5.12	3.13	2.00	1.28
44.0 l/s	2640 l/min	R					1853.54	565.73	228.01	90.74	32.85	17.35	5.07	1.68	0.56
	v	v					33.65	21.20	14.86	10.34	6.92	5.36	3.27	2.09	1.34
46.0 l/s	2760 l/min	R					2023.71	617.35	248.69	98.91	35.78	18.89	5.52	1.82	0.61
	v	v					35.18	22.17	15.54	10.81	7.23	5.61	3.42	2.19	1.40
48.0 l/s	2880 l/min	R					2201.34	671.23	270.27	107.43	38.84	20.49	5.98	1.97	0.66
	v	v					36.71	23.13	16.21	11.28	7.55	5.85	3.57	2.28	1.46
50.0 l/s	3000 l/min	R					2386.43	727.35	292.74	116.30	42.02	22.16	6.46	2.13	0.71
	v	v					38.24	24.01	16.89	11.75	7.86	6.01	3.72	2.38	1.52
52.0 l/s	3120 l/min	R					2578.98	785.72	316.11	125.52	45.32	23.89	6.96	2.29	0.76
	v	v					39.77	25.06	17.56	12.22	8.17	6.34	3.87	2.47	1.58
54.0 l/s	3240 l/min	R					2779.00	846.33	340.36	135.09	48.74	25.69	7.47	2.46	0.82
	v	v					41.30	26.02	18.24	12.69	8.49	6.58	4.02	2.57	1.64
56.0 l/s	3360 l/min	R					2986.47	909.19	365.51	145.00	52.29	27.55	8.01	2.64	0.88
	v	v					42.83	26.99	18.91	13.16	8.80	6.83	4.17	2.66	1.70
58.0 l/s	3480 l/min	R					3201.40	974.30	391.55	155.28	55.96	29.47	8.56	2.82	0.94
	v	v					44.36	27.95	19.59	13.63	9.12	7.07	4.32	2.76	1.76

\dot{V} = Volumetric current [l/s]

R = Pressure gradient [mbar/m]

v = Flow rate [m/s]

Pipe friction factor R and calculated flow rate v in dependence on the volumetric current \dot{V}

climatherm-pipe SDR 11 - **climatherm**-faser composite pipe SDR 11











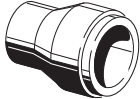
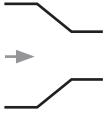

Temperature: 70 °C

Roughness: 0.0070 mm Density: 977.7 kg/m³ Viscosity: 0.41 x 10⁻⁶ m²/s

\dot{V}		Di- men- sion	20.0 mm	25.0 mm	32.0 mm	40.0 mm	50.0 mm	63.0 mm	75.0 mm	90.0 mm	110.0 mm	125.0 mm	160.0 mm	200.0 mm	250.0 mm
60.0 l/s	3600 l/min	R						1041.65	418.49	165.89	59.76	31.46	9.13	3.00	1.00
	v	v						28.92	20.26	14.10	9.43	7.31	4.47	2.85	1.82
62.0 l/s	3720 l/min	R						1111.25	446.31	176.85	63.67	33.51	9.72	3.19	1.06
	v	v						29.88	20.94	14.57	9.75	7.56	4.61	2.95	1.89
64.0 l/s	3840 l/min	R						1183.01	475.03	188.17	67.71	35.62	10.33	3.39	1.12
	v	v						30.84	21.61	15.04	10.06	7.80	4.76	3.04	1.95
66.0 l/s	3960 l/min	R						1257.19	504.64	199.83	71.88	37.80	10.95	3.59	1.19
	v	v						31.81	22.29	15.51	10.37	8.05	4.91	3.14	2.01
68.0 l/s	4080 l/min	R						1333.53	535.14	211.83	76.16	40.04	11.59	3.80	1.26
	v	v						32.77	22.97	15.98	10.69	8.29	5.06	3.23	2.07
70.0 l/s	4200 l/min	R						1412.11	566.54	224.19	80.57	42.35	12.25	4.02	1.33
	v	v						33.74	23.64	16.45	11.00	8.53	5.21	3.33	2.13
72.0 l/s	4320 l/min	R						1492.94	598.83	236.90	85.11	44.72	12.93	4.24	1.40
	v	v						34.70	24.32	16.92	11.32	8.78	5.36	3.43	2.19
74.0 l/s	4440 l/min	R						1576.02	632.01	249.95	89.76	47.15	13.63	4.46	1.48
	v	v						35.66	24.99	17.39	11.63	9.02	5.51	3.52	2.25
76.0 l/s	4560 l/min	R						1661.34	666.08	263.36	94.54	49.65	14.34	4.69	1.55
	v	v						36.63	25.67	17.86	11.95	9.26	5.66	3.62	2.31
78.0 l/s	4680 l/min	R						1748.91	701.05	277.11	99.44	52.21	15.07	4.93	1.63
	v	v						37.59	26.34	18.33	12.26	9.51	5.80	3.71	2.37
80.0 l/s	4800 l/min	R						1838.72	736.90	291.21	104.46	54.83	15.82	5.17	1.71
	v	v						38.55	27.02	18.80	12.58	9.75	5.95	3.81	2.43
85.0 l/s	5100 l/min	R						2073.08	830.45	327.98	117.56	61.67	17.77	5.80	1.91
	v	v						40.96	28.71	19.98	13.36	10.36	6.33	4.04	2.59
90.0 l/s	5400 l/min	R						2321.49	929.57	366.93	131.42	68.91	19.83	6.47	2.13
	v	v						43.37	30.40	21.15	14.15	10.97	6.70	4.28	2.74
95.0 l/s	5700 l/min	R							1034.27	408.06	146.06	76.54	22.01	7.17	2.36
	v	v							32.08	22.33	14.93	11.58	7.07	4.52	2.89
100.0 l/s	6000 l/min	R							1144.54	451.36	161.46	84.57	24.29	7.91	2.60
	v	v							33.77	23.50	15.72	12.19	7.44	4.76	3.04
105.0 l/s	6300 l/min	R							1260.39	496.84	177.62	93.00	26.69	8.68	2.85
	v	v							35.46	24.68	16.50	12.80	7.81	4.99	3.19



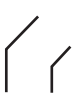
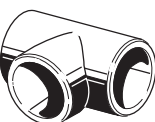
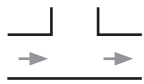
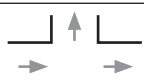
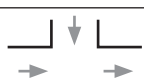
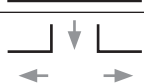

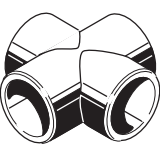
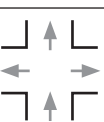
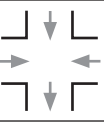





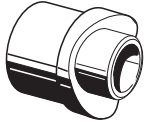
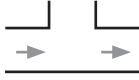

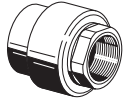
\dot{V} = Volumetric current [l/s] R = Pressure gradient [mbar/m] v = Flow rate [m/s]

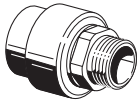
Coefficient of loss ζ **fusiotherm**[®]-fittings

Fitting	Picture	Symbol	Comment	ζ -Value
Socket				0.25
Reducer			Reduction...	
			...by 1 dimension	0.40
			...by 2 dimension	0.50
			...by 3 dimension	0.60
			...by 4 dimension	0.70
			...by 5 dimension	0.80
Elbow 90°				1.20
Elbow 90° male/female				1.20
Elbow 45°				0.50
Elbow 45° male/female				0.50
Tee				0.25
			Separation of flow	1.20
			Conjunction of flow	0.80
			Counter current in case of separation of flow	1.80
			Counter current in case of conjunction of flow	3.00
Reducing tee	The ζ -value results from the addition of tee and reducer			
Cross			Separation of flow	2.10
			Conjunction of flow	3.70

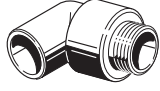

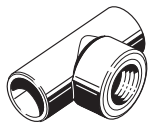
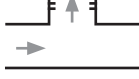
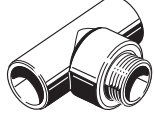





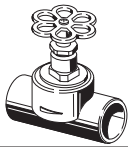

[ = flow direction]

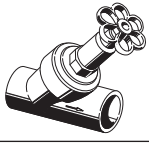
Coefficient of loss ζ fusiotherm[®]-fittings

Fitting	Picture	Symbol	Comment	ζ -Value
Weld-in saddle				0.25
			Separation of flow	0.5
			Counter current in case of conjunction of flow	1.00
Reducing tee	The ζ -value results from the addition of the weld in saddle and tee			
Transition piece with female thread				0.50
Transition piece with female thread				0.70
Elbow with male thread				1.40
Elbow with male thread				1.60
Transition tee with female thread			Separation of flow	
			- 16 x 1/2" x 16 - 20 x 3/4" x 20	1.40
			- 20 x 1/2" x 20 - 25 x 3/4" x 25 - 32 x 1" x 32	1.60
			- 25 x 1/2" x 25 - 32 x 3/4" x 32	1.80
Threaded branch tee with male thread			Separation of flow - 20 x 1/2" x 20	1.80

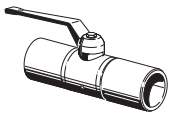
[→ = flow direction]

Coefficient of loss ζ **fusiotherm**[®]-fittings

Fitting	Picture	Symbol	Comment	K_v
Screw-down stop globe valve			- 20 mm	
			- 25 mm	
			- 32 mm	
			- 40 mm	
Inclined valve			- 20 mm	
			- 25 mm	
			- 32 mm	
			- 40 mm	
Non-return valve			- 20 mm	
			- 25 mm	
			- 32 mm	
			- 40 mm	
Ball valve			- 20 mm	
			- 25 mm	
			- 32 mm	
			- 40 mm	
			- 50 mm	
- 63 mm				
Draining branch				

[→ = flow direction]

Source: DIN 1988 Part 3

$$Z = \frac{\zeta v^2 \delta}{2}$$

Z = Pressure lost in [Pa]

 ζ = Coefficient of loss of fitting

v = Flow rate [m/s]

 δ = Density of medium [kg/m³]

[K_v = Cold Water Volume Rate circulatory [m³/h] of water [5 °C - 30 °C] at a pressure difference of 1 bar]

Note:

For the determination of pressure loss in (mbar) the result has to be divided by the factor 100 (100Pa = 1 mbar).

1bar = 10⁵ Pa = 14,5 psi = 10 N/cm²)

Coefficient of loss ζ fusiotherm® - distribution block

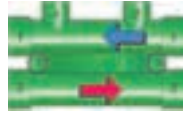
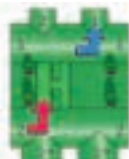
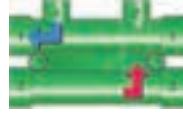
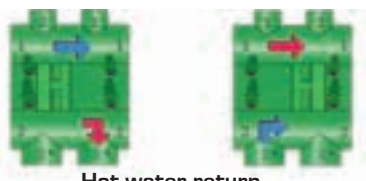
Picture	Comment	Picture	Comment	ζ -Value
Potable water installation Cold water Hot water 	Reduced 25 mm passage in case of separation of flow	Heating installation Return Flow 	Reduced 20 mm passage in case of separation of flow	1.00
	25 mm passage in case of separation of flow		20 mm passage in case of separation of flow	0.25
Potable water installation Cold water Hot water 	20 mm passage in case of separation of flow	Heating installation Return Flow 	16 mm branch in case of separation of flow	0.80
	20 mm branch in case of conjunction of flow		16 mm branch in case of conjunction of flow	1.60
	Reduced 20 mm passage in case of separation of flow		16 mm branch in case of separation of flow	2.20
Potable water installation Cold water Hot water Hot water return 		Heating installation Hot water Cold water	25 mm branch in case of separation of flow	1.20
			16 mm branch in case of conjunction of flow	0.80

Chapter 6

Product Range

pipes

fusiotherm®-pipe SDR 6

Material: fusiolen PP-R

Pipe series : SDR 6 / S 2.5
 Standard: DIN 8077 / 78,
 DIN EN ISO 15874

Registrations: DVGW, ÖVGW, SVGW, KIWA, SAI,
 TIN, TSE, SITAC, SII, LNEC, AENOR,
 Shipbuilding, IIP

Colour: green

Form supplied: 4 m straight lengths, also* in coils

Packing Unit: PU in meter

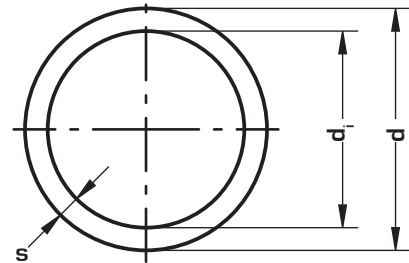

DVGW-System Certification:
 including fittings, connection pieces
 and connection technique

Fields of application:

The relation between working temperature, pressure load and service years can be found in chapter 1.

Product approved by



Pipe			Dimension	Wall thickness	Internal diameter	Water content	Weight	
Art.-No.	Dimension	Packing unit	d	s	di	l / m	kg / m	DN
			mm	mm	mm			
10006	16 mm ¹⁾	100	16	2.7	10.6	0.088	0.110	10
10008	20 mm	100	20	3.4	13.2	0.137	0.171	12
10010	25 mm	100	25	4.2	16.6	0.216	0.266	15
10012	32 mm	40	32	5.4	21.2	0.353	0.427	20
10014	40 mm	40	40	6.7	26.6	0.555	0.660	25
10016	50 mm	20	50	8.3	33.4	0.876	1.054	32
10018	63 mm	20	63	10.5	42.0	1.385	1.697	40
10020	75 mm	20	75	12.5	50.0	1.963	2.328	50
10022	90 mm	12	90	15.0	60.0	2.826	3.415	60
10024	110 mm	8	110	18.3	73.4	4.229	5.150	65
The following items * are supplied in coils:								
10106*	16 mm	100	16	2.7	10.6	0.088	0.110	10
10108*	20 mm	100	20	3.4	13.2	0.137	0.172	12
10110*	25 mm	100	25	4.2	16.6	0.216	0.266	15

¹⁾ Important! Only weld diameter 16 mm with application of pipe supporting sleeve Art.-No. 10186

** According the current list of licensed countries

pipes

fusiotherm®-pipe SDR 7.4

Material: fusiotherm PP-R
 Pipe series : SDR 7,4 / S 3,2
 Standards: DIN 8077 / 78,
 DIN EN ISO 15874,
 ASTM F 2389, CSA B 13711
 Registrations: ÖNORM, SAI, TIN, TSE, LNEC,
 AENOR, SKZ A 175, Shipbuilding, IIP
 Colour: green
 Form supplied: 4 m straight lengths, also* in coils
 Packing Unit: in meter



Fields of application:

The relation between working temperature, pressure load and service years can be found in chapter 1.

Product approved by

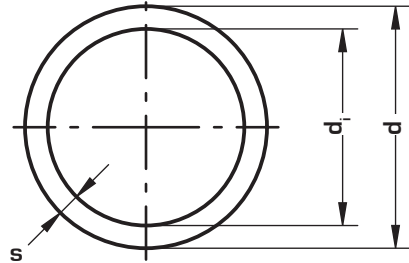

Pipe			Dimension	Wall thickness	Internal diameter	Water content	Weight	
Art.-No.	Dimension	Packing unit	d	s	d _i	l / m	kg / m	DN
			mm	mm	mm			
10806	16 mm ¹⁾	100	16	2.2	11.6	0.106	0.098	12
10808	20 mm	100	20	2.8	14.4	0.163	0.152	15
10810	25 mm	100	25	3.5	18.0	0.254	0.235	20
10812	32 mm	40	32	4.4	23.2	0.423	0.375	25
10814	40 mm	40	40	5.5	29.0	0.660	0.580	32
10816	50 mm	20	50	6.9	36.2	1.029	0.905	40
10818	63 mm	20	63	8.6	45.8	1.647	1.420	50
10820	75 mm	20	75	10.3	54.4	2.323	2.020	50
10822	90 mm	12	90	12.3	65.4	3.358	2.890	65
10824	110 mm	8	110	15.1	79.8	4.999	4.320	80
The following items * are supplied in coils:								
10906*	16 mm	100	16	2.2	11.6	0.106	0.095	12
10908*	20 mm	100	20	2.8	14.4	0.163	0.148	15

¹⁾ Important! Only weld diameter 16 mm with application of pipe supporting sleeve Art.-No. 85110.

** According the current list of licensed countries

pipes

fusiotherm®-pipe SDR 11

Material: fusiotherm PP-R
 Pipe series : SDR 11 / S 5
 Standards: DIN 8077 / 78,
 DIN EN ISO 15874,
 ASTM F 2389, CSA B 13711
 Registrations: ÖNORM, SAI, TIN, TSE, LNEC,
 AENOR, SKZ A 175, Shipbuilding, IIP
 Colour: green with 4 blue stripes
 Form supplied: 4 m straight lengths, also* in coils
 Packing Unit: in meter
 Application: Drinking water, gen. pressure pipes



Fields of application:

I.a.: cold water and rain water pipes.

The relation between working temperature, pressure load and service years can be found in chapter 1.

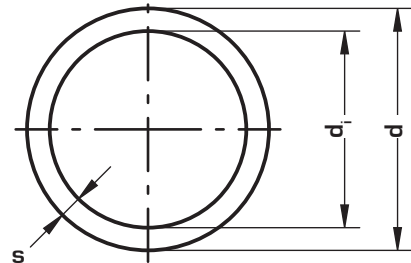

Product approved by



Pipe			Dimension	Wall thickness	Internal diameter	Water content	Weight	
Art.-No.	Dimension	Packing unit	d	s	d _i	l / m	kg / m	DN
			mm	mm	mm			
10208	20 mm	100	20	1.9	16.2	0.206	0.109	15
10210	25 mm	100	25	2.3	20.4	0.327	0.165	20
10212	32 mm	40	32	2.9	26.2	0.539	0.265	25
10214	40 mm	40	40	3.7	32.6	0.834	0.415	32
10216	50 mm	20	50	4.6	40.8	1.307	0.645	40
10218	63 mm	20	63	5.8	51.4	2.074	1.015	50
10220	75 mm	20	75	6.8	61.4	2.959	1.415	65
10222	90 mm	12	90	8.2	73.6	4.252	2.045	80
10224	110 mm	8	110	10.0	90.0	6.359	3.136	80
10226	125 mm	4	125	11.4	102.2	8.199	3.927	100
10230	160 mm	4	160	14.6	130.8	13.430	6.416	125
10234	200 mm	4	200	18.2	163.6	21.010	9.990	150
10238	250 mm	4	250	22.7	204.6	32.861	15.540	200
The following items * are supplied in coils:								
10308*	20 mm	100	20	1.9	16.2	0.206	0.109	15
10310*	25 mm	100	25	2.3	20.4	0.327	0.158	20
10312*	32 mm	50	32	2.9	26.2	0.539	0.257	25

** According to the current list of licensed countries

aquatherm-faser composite pipe technology

fusiotherm[®]-faser composite pipe

Composed of fusiotherm[®] PP-R and a special faser filling in the middle layer of the material fusiotherm[®] PP-R.

The favourable, resistant and innovative pipe technology has proven itself worldwide in more than 70 countries.

**Australia | Albania | Austria | Algeria
Belgium | Bosnia Hercegovina | Botswana
Brazil | Bulgaria
Canada | China | Corea | Croatia
Cuba | Czech Republik
Denmark | Dominican Republic
Egypt | Estonia
Faroe Island | Finland | France
Georgia | Germany | Great Britain | Greece
Hungaria | Hong Kong
Iceland | India | Ireland | Israel | Italy
Japan
Korea | Katar | Kuwait | Kazachstan
Latvia | Libanon | Luxembourg | Lithuania
Malta | Maroc | Moldavia | Montenegro
Namibia | Netherlands | New Zealand | Norway Oman
Poland | Portugal | Philippines
Qatar
Romania | Russia
Saudi Arabia | Serbia | Singapore
Slovenia | Slovak Republic | Spain | South Africa
Sri Lanka | Switzerland | Sweden | Syria
Turkey | Thailand | Tunesia
Ukraine | USA
U.A.E.
Vietnam**



The advantages:

- Resistant against corrosion
- The linear expansion has been reduced by 75%
- The flow has been increased by 20% at same loading capacity due to bigger inner diameter
- High stability and carrying capacity
- High impact strength
- Easy processing: simply cut and weld

Various applications to:

- Cold and hot potable water application
- Heating systems
- Rainwater application
- Compressed air systems
- Swimming pool installations
- Pipelines for industrial use

pipes

fusiotherm®-faser composite SDR 7.4

Material: fusiotherm PP-R fibre reinforced
 Pipe series: SDR 7.4 / S 3.2
 Standards: SKZ HR 3.28, ASTM F 2389, CSA B 137.11
 Registrations: ÖVGW, SVGW, SAI-Global, SKZ A 314, TIN, TSE, Shipbuilding
 Colour: green with 4 dark green stripes
 Form supplied: 4 m straight lengths
 Packing Unit: in meter
 Application: Drinking water, gen. pressure pipes



mechanically stabilized through a faser mix integrated in the middle layer of the fusiotherm® PP-R

Identification:
 4 moss-green stripes

The relation between working temperature, pressure load and service years can be found in chapter 1.

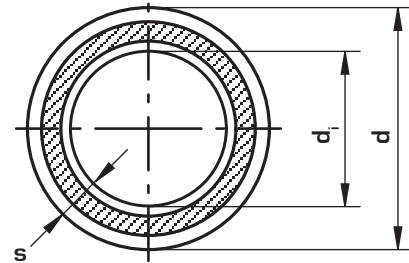

Product approved by



Pipe			Dimension	Wall thickness	Internal diameter	Water content	Weight	
Art.-No.	Dimension	Packing unit	d	s	d _i	l / m	kg / m	DN
			mm	mm	mm			
70708	20 mm	100	20	2.8	14.4	0.163	0.158	15
70710	25 mm	100	25	3.5	18.0	0.254	0.246	20
70712	32 mm	40	32	4.4	23.2	0.423	0.394	25
70714	40 mm	40	40	5.5	29.0	0.660	0.613	32
70716	50 mm	20	50	6.9	36.2	1.029	0.955	40
70718	63 mm	20	63	8.6	45.8	1.647	1.500	50
70720	75 mm	20	75	10.3	54.4	2.323	2.135	50
70722	90 mm	12	90	12.3	65.4	3.358	3.058	65
70724	110 mm	8	110	15.1	79.8	4.999	4.576	80
70726	125 mm	4	125	17.1	90.8	6.472	5.891	-
70730	160 mm	4	160	21.9	116.2	10.599	9.538	125
70734	200 mm	4	200	27.4	145.2	16.558	15.051	150
70738	250 mm	4	250	34.2	181.6	25.901	23.479	175

* According the current list of licensed countries

pipes

fusiotherm®-faser composite pipe SDR 7.4 UV

Material: fusiotherm PP-R with UV protection layer
 Pipe series: SDR 7.4 / S 3.2
 Standards: SKZ HR 3.28, ASTM F2389, CSA B 13711
 Registrations: ÖVGW, SVGW, SAI-Global, SKZ A 314, TIN, TSE, Shipbuilding
 Colour: Inliner green with 4 dark green stripes, outside black
 Form supplied: 4 m straight lengths
 Packing Unit: in meter
 Application: Drinking water, gen. pressure pipes

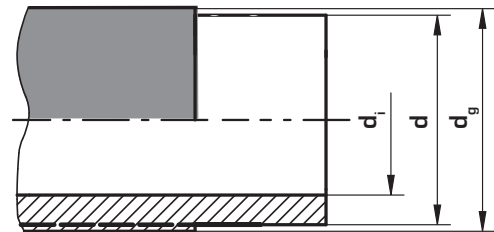
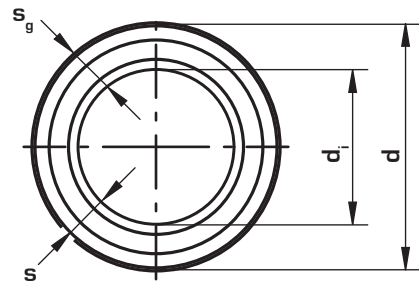
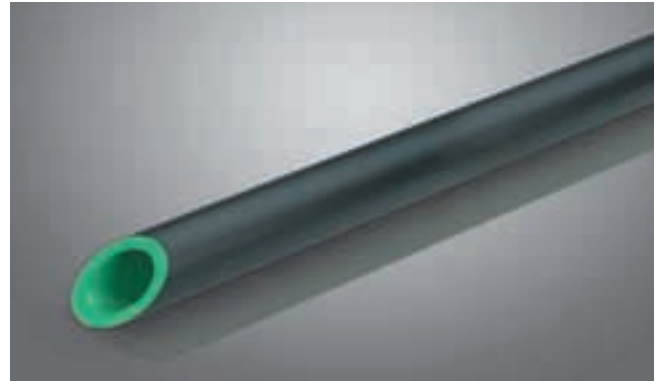

Mechanically stabilized through a faser mix integrated in the middle layer of fusiotherm® PP-R

Identification:

Inliner green with 4 dark green stripes, outside black

The relation between working temperature, pressure load and service years can be found in chapter 1.

Pipe			Dimension	Wall thickness	Internal diameter	(d) total	(s) total	Water content	Weight	
Art.-No.	Dimension	Packing unit	d	s	d _i	d _g	s _g	l/ m	kg/ m	DN
			mm	mm	mm	mm	mm			
70758	20 mm	100	20	2.8	14.4	21.9	3.7	0.163	0.211	15
70760	25 mm	100	25	3.5	18.0	27.0	4.5	0.254	0.316	20
70762	32 mm	40	32	4.4	23.2	34.1	5.4	0.423	0.488	25
70764	40 mm	40	40	5.5	29.0	42.2	6.6	0.660	0.733	32
70766	50 mm	20	50	6.9	36.2	52.3	8.0	1.029	1.108	40
70768	63 mm	20	63	8.6	45.8	65.4	9.8	1.647	1.697	50
70770	75 mm	20	75	10.3	54.4	77.4	11.5	2.323	2.323	50
70772	90 mm	12	90	12.3	65.4	93.0	13.8	3.358	3.400	65
70774	110 mm	8	110	15.1	79.8	113.6	16.9	4.999	5.093	80
70776	125 mm	4	125	17.1	90.8	128.6	18.9	6.472	6.450	80
70780	160 mm*	4	160	21.9	113.2	160.0	23.4	10.059	10.130	100
70784	200 mm	4	200	27.4	141.8	200.0	29.1	15.784	15.763	150
70788	250 mm	4	250	34.2	177.6	250.0	36.2	24.760	24.528	175

* cannot be used in connection with electrofusion socket Art. No. 17230

pipes

fusiotherm®-stabi composite pipe SDR 7.4

Material: fusiolen PP-R, aluminium
 Pipe series: SDR 7.4 / S 3.2 (Inliner)
 Standards: Inliner: DIN 8077 / 78,
 DIN EN ISO 15874
 Composite pipe: DVGW W542,
 ÖNORM B 5157
 Registrations: DVGW, ÖVGW, SVGW, KIWA, SAI,
 TIN, TSE, Shipbuilding
 Colour: green
 Form supplied: 4 m straight lengths, also * in coils
 Packing Unit: in meter

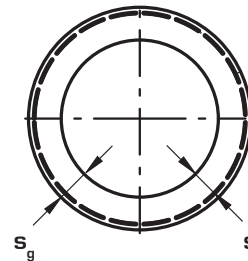

mechanically stabilized through integrated aluminium-layer

Identification:
 evenly perforated surface

DVGW-Certification for all nominal diameter (Ø 16 - 110 mm)

Fields of application:
 The relation between working temperature, pressure load and service years can be found in chapter 1.

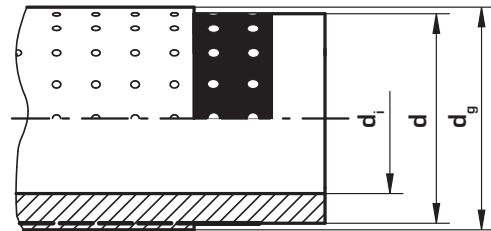

Pipe			Dimension	Wall thickness	Internal diameter	(d) total	(s) total	Water content	Weight	
Art.-No.	Dimension	Packing unit	d	s	d _i	d _g	s _g	l/ m	kg/ m	DN
			mm	mm	mm	mm	mm			
70806	16 mm	100	16	2.2	11.6	17.8	3.1	0.106	0.144	12
70808	20 mm	100	20	2.8	14.4	21.9	3.7	0.163	0.216	15
70810	25 mm	100	25	3.5	18.0	27.0	4.5	0.254	0.296	20
70812	32 mm	40	32	4.5	23.0	34.1	5.5	0.415	0.471	25
70814	40 mm	40	40	5.6	28.8	42.2	6.7	0.651	0.739	32
70816	50 mm	20	50	6.9	36.2	52.3	8.0	1.029	1.025	40
70818	63 mm	20	63	8.7	45.6	65.4	9.9	1.632	1.610	50
70820	75 mm	20	75	10.4	54.2	77.4	11.6	2.306	2.197	50
70822	90 mm	12	90	12.5	65.0	93.0	14.0	3.317	3.226	65
70824	110 mm	8	110	15.2	79.6	113.6	17.0	4.974	4.735	80
The following items * are supplied in coils:										
70856*	16 mm	100	16	2.2	11.6	17.8	3.1	0.106	0.150	12

pipes

climatherm-pipe SDR 11

Material: fusiolen PP-R
 Pipes series: SDR 11/S 5
 Standards: DIN 8077 / 78,
 DIN EN ISO 15874, ASTM F 2389,
 CSA B 137.11, NSF 14
 Registrations: TIN (Poland), EMI-TÜV (Hungary),
 LNEC (Portugal), CentrSEPRO (Ukraine),
 cNSFus-Industrial,
 IAPMO- (Kanada / USA)
 Colour: blue with 4 green stripes
 Form supplied: 4 m straight lengths, also * in coils
 Application: HVAC, non-potable water applications

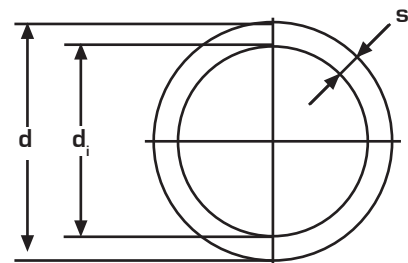
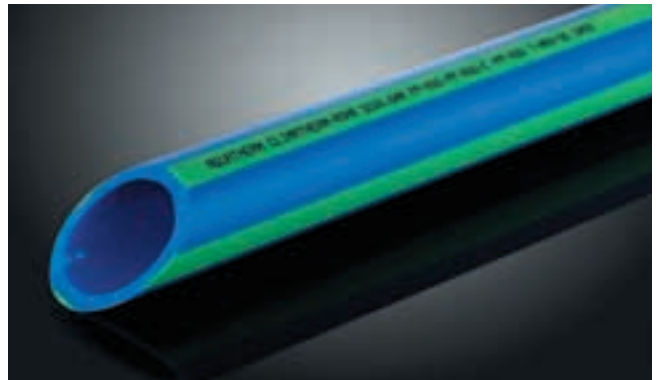

Fields of application:

For chilled/ hot water and heating systems with a max. pressure of 10 bars and operating temperature of -20°C up to +20°C. Temperatures up to 90°C can be found in the table of permissible working pressures (chapter 1).

Pipe				Dimension	Wall thickness	Internal diameter	Water content	Weight	
Art.-No.	Dimension	SDR	Packing unit	d	s	d _i	l / m	kg / m	DN
				mm	mm	mm			
2010208	20 mm	11	100	20	1.9	16.2	0.206	0.110	15
2010210	25 mm	11	100	25	2.3	20.4	0.327	0.167	20
2010212	32 mm	11	40	32	2.9	26.2	0.539	0.265	25
2010214	40 mm	11	40	40	3.7	32.6	0.834	0.415	32
2010216	50 mm	11	20	50	4.6	40.8	1.307	0.643	40
2010218	63 mm	11	20	63	5.8	51.4	2.074	1.014	50
2010220	75 mm	11	20	75	6.8	61.4	2.959	1.414	65
2010222	90 mm	11	12	90	8.2	73.6	4.252	2.045	80
2010224	110 mm	11	8	110	10.0	90.0	6.359	3.028	80
2010226	125 mm	11	4	125	11.4	102.2	8.199	3.928	100
2010230	160 mm	11	4	160	14.6	130.8	13.430	6.420	125
The following items * are supplied in coils:									
2010308*	20 mm	11	100	20	1.9	16.2	0.206	0.107	15
2010310*	25 mm	11	100	25	2.3	20.4	0.327	0.164	20
2010312*	32 mm	11	40	32	2.9	26.2	0.539	0.265	25

pipes

climatherm-faser composite pipe SDR 7.4 / SDR 11

- Material: fusiolen PP-R; fibre reinforced
- Pipe series : Art.-No. 2070708 / 2070712 = **SDR 7.4**
Art.-No. 2070112 - 2070138 = **SDR 11**
- Standards: SKZ HR 3.28, ASTM F2389,
CSA B 137.11, NSF 14
- Registrations: TIN (Poland), EMI-TÜV (Hungary),
LNEC (Portugal), CentrSEPRO (Ukraine),
cNSFus-Industrial,
IAPMO- (Kanada / USA)
- Colour: blue with 4 green stripes
- Form supplied: 4 m straight lengths
- Packing unit: PU in meter
- Application: HVAC, non-potable water applications

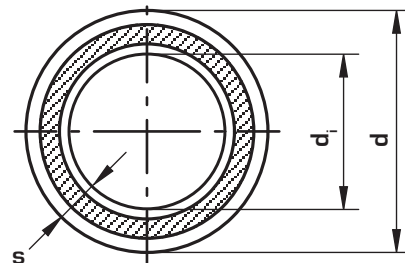
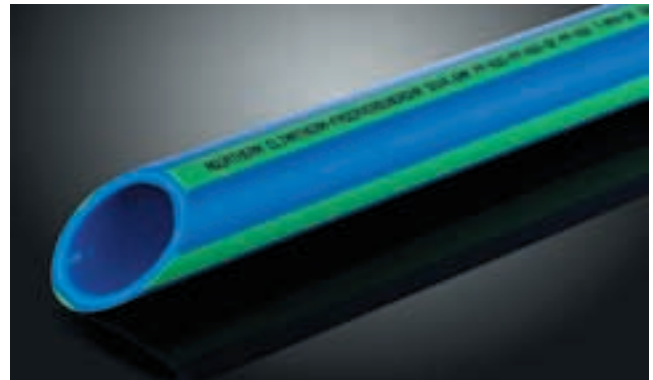

Fields of application:

For chilled / hot water and heating systems with a max. pressure of 10 bars and operating temperature of -20°C up to +20°C. Temperatures up to 90°C can be found in the table of permissible working pressures (chapter 1).

Pipe				Dimension	Wall thickness	Internal diameter	Water content	Weight	
Art.-No.	Dimension	SDR	Packing unit	d	s	d _i	l / m	kg / m	DN
				mm	mm	mm			
2070708	20 mm	7.4	100	20	2.8	14.4	0.163	0.159	15
2070710	25 mm	7.4	100	25	3.5	18.0	0.254	0.248	20
2070712	32 mm	7.4	40	32	4.4	23.2	0.423	0.397	25
2070112	32 mm	11	40	32	2.9	26.2	0.539	0.281	25
2070114	40 mm	11	40	40	3.7	32.6	0.834	0.435	32
2070116	50 mm	11	20	50	4.6	40.8	1.307	0.675	40
2070118	63 mm	11	20	63	5.8	51.4	2.074	1.065	50
2070120	75 mm	11	20	75	6.8	61.4	2.959	1.482	65
2070122	90 mm	11	12	90	8.2	73.6	4.252	2.145	80
2070124	110 mm	11	8	110	10.0	90.0	6.359	3.175	80
2070126	125 mm	11	4	125	11.4	102.2	8.199	4.118	100
2070130	160 mm	11	4	160	14.6	130.8	13.430	6.728	125
2070134	200 mm	11	4	200	18.2	163.6	21.010	10.480	150
2070138	250 mm	11	4	250	22.7	204.6	32.861	16.300	200

pipes

climatherm-faser composite pipe SDR 7.4/SDR 11 UV

- Material: fusiolen PP-R fibre reinforced with UV protection layer
- Pipe serie : Art.-No. 2070758-2070762 = **SDR 7.4**
Art.-No. 2070162-2070188 = **SDR 11**
- Standards: DIN 8077 / 78,
DIN EN ISO 15874, ASTM F 2389,
CSA B 137.11, NSF 14
- Registrations: TIN (Poland), EMI-TÜV (Hungary),
LNEC (Portugal), CentrSEPRO (Ukraine)
- Colour: Inliner bkue with 4 green stripes,
outside black
- Form supplied: 4 m straight lengths
- Packing unit: PU in meter
- Application: HVAC, non-potable water applications

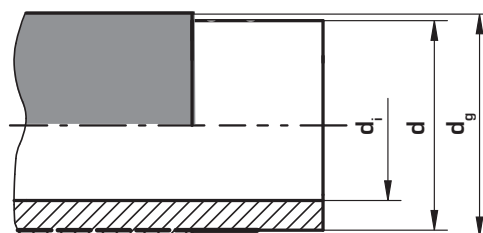
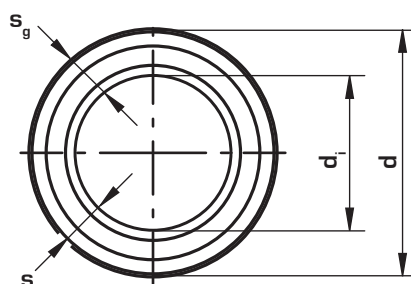
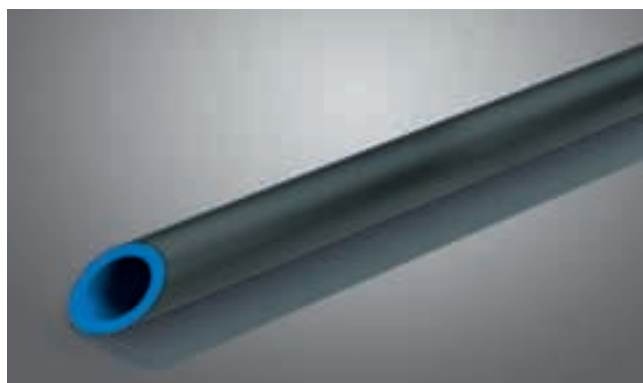

Fields of application:

For chilled/ hot water and heating systems with a max. pressure of 10 bars and operating temperature of -20°C up to +20°C. Temperatures up to 90°C can be found in the table of permissible working pressures (chapter 1).

Pipe				Dimension	Wall thickness	Internal diameter	(d) total	(s) total	Water content	Weight	
Art.-No.	Dimension	SDR	Packing unit	d	s	d _i	d _g	s _g	l/ m	kg/ m	DN
				mm	mm	mm	mm	mm			
2070758	20	7.4	100	20	2.8	14.4	21.9	3.7	0.163	0.211	15
2070760	25	7.4	100	25	3.5	18.0	27.0	4.5	0.254	0.316	20
2070762	32	7.4	40	32	4.4	23.2	34.1	5.5	0.423	0.488	20
2070162	32	11	40	32	2.9	26.2	34.1	3.9	0.539	0.370	25
2070164	40	11	40	40	3.7	32.6	42.2	4.8	0.834	0.551	32
2070166	50	11	20	50	4.6	40.8	52.3	5.7	1.307	0.820	40
2070168	63	11	20	63	5.8	51.4	65.4	7.0	2.074	1.251	50
2070170	75	11	20	75	6.8	61.4	77.4	8.0	2.959	1.698	50
2070172	90	11	12	90	8.2	73.6	93.0	9.7	4.252	2.470	65
2070174	110	11	8	110	10.0	90.0	113.6	11.8	6.359	3.668	80
2070176	125	11	4	125	11.4	102.2	128.6	13.2	8.199	4.647	100
2070180	160	11	4	160	14.6	127.8	160.0	16.1	12.821	7.257	125
2070184	200	11	4	200	18.2	160.2	200.0	19.9	20.146	11.224	150
2070188	250	11	4	250	22.7	200.6	250.0	24.7	31.589	17.399	200

* cannot be used in connection with electrofusion socket Art. No. 17230

pipes

aquatherm® lilac-pipe SDR 7.4 / 11

- Material: fusiolen PP-R
- Pipe series : Art.-No. 9010808 / 9010810 = **SDR 7.4**
Art.-No. 9010212 - 9010238 = **SDR 11**
- Standards: DIN 8077 / 78,
DIN EN ISO 15874, ASTM F 2389,
CSA B 137:11, NSF 14
- Registrations: cNSFus-rw
- Colour: violet
- Form supplied: 4 m straight lengths
- Packing unit: PU in meter
- Application: Recycled / reclaimed water



Fields of application:
for recycled / reclaimed water

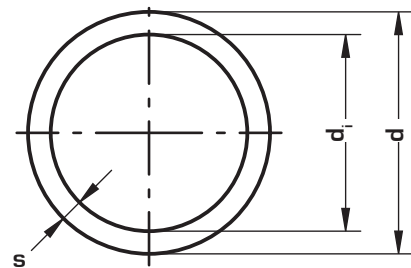

Pipe				Dimension	Wall thickness	Internal diameter	Water content	Weight	
Art.-No.	Dimension	SDR	Packing unit	d	s	d _i	l / m	kg / m	DN
				mm	mm	mm			
9010808	20	7.4	100	20	2.8	14.4	0.163	0.148	15
9010810	25	7.4	100	25	3.5	18.0	0.254	0.230	20
9010212	32	11	40	32	2.9	26.2	0.539	0.261	25
9010214	40	11	40	40	3.7	32.6	0.834	0.412	32
9010216	50	11	20	50	4.6	40.8	1.307	0.638	40
9010218	63	11	20	63	5.8	51.4	2.074	1.010	50
9010220	75	11	20	75	6.8	61.4	2.959	1.410	65
9010222	90	11	12	90	8.2	73.6	4.252	2.030	80
9010224	110	11	8	110	10.0	90.0	6.359	3.010	80
9010226	125	11	4	125	11.4	102.2	8.199	3.910	100
9010230	160	11	4	160	14.6	130.8	13.430	6.380	125
9010234	200	11	4	200	18.2	163.6	21.010	9.950	150
9010238	250	11	4	250	22.7	204.6	32.861	15.500	200

Accessories

fusiotherm®-pipe support

Art.-No.	Dimension	kg / pc	Packing unit m / pc	Box unit m / pc	Piece
85110	for pipes \varnothing 16 x 2.2 mm - \varnothing 11.4 mm	0.004	10	600	600
10186	for pipes \varnothing 16 x 2.7 mm - \varnothing 10.4 mm	0.004	10	500	500

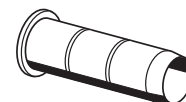

fusiotherm®-pipe clamps

for fusiotherm®-pipes

Art.-No.	Dimension	kg / pc	Packing unit m / pc	Box unit m / pc	Piece
60516	16 mm	0.045	50	50	
60520	20 mm	0.048	50	50	
60525	25 mm	0.051	50	50	
60532	32 mm	0.060	50	50	
60540	40 mm	0.067	50	50	
60550	50 mm	0.079	50	50	
60563	63 mm	0.091	25	25	
60575	75 mm	0.105	25	25	
60590	90 mm	0.128	25	25	
60594	110 mm	0.155	25	25	
60595	125 mm	0.212	25	25	
60597	160 mm	0.342	25	25	
60650	200 mm	1.014	1	18	
60654	250 mm	1.193	1	12	

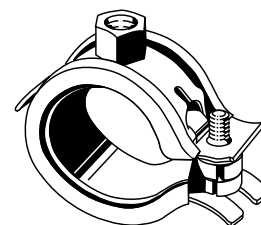

Suitable for sliding and fixed point installation.

Thread connection:
 M8 & M10 for 16 - 125 mm
 M10 for 160 mm
 M16 for 200 & 250 mm

fusiotherm®-pipe fastening bow

suitable for 16-32 mm fusiotherm®- and aquatherm® SHT-pipes

Art.-No.	Dimension	kg / pc	Packing unit m / pc	Box unit m / pc	Piece
60604	single - length = 45 mm	0.005	50	4000	
60606	single - length = 75 mm	0.007	50	3000	
60608	double - length = 45 mm	0.007	50	2500	
60610	double - length = 75 mm	0.009	50	1750	

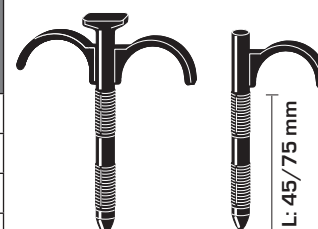

Accessories and fittings

fusiotherm®-plastic pipe clamps

suitable for fusiotherm® and aquatherm® SHT-pipes

Art.-No.	Dimension	kg / pc	Packing unit m / pc	Box unit m / pc	Piece
60616	16 mm	0.007	50	3000	
60620	20 mm	0.008	50	3000	
60625	25 mm	0.016	50	1500	

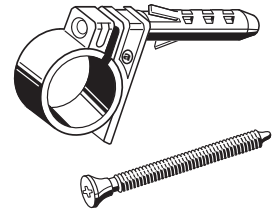

fusiotherm®-socket

Art.-No.	Dimension	kg / pc	Packing unit m / pc	Box unit m / pc	Piece
11006	16 mm	0.008	10	2000	
11008	20 mm	0.011	10	2000	
11010	25 mm	0.018	10	1000	
11012	32 mm	0.027	5	600	
11014	40 mm	0.043	5	400	
11016	50 mm	0.087	5	200	
11018	63 mm	0.125	1	100	
11020	75 mm	0.208	1	80	
11022	90 mm	0.332	1	50	
11024	110 mm	0.592	1	30	
11026	125 mm	0.809	1	25	

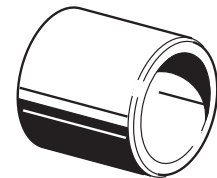

Fittings

fusiotherm® - reducer

Art.-No.	Dimension	kg / pc	Packing unit m / pc	Box unit m / pc	Piece
11109	20/16 mm	0.009	10	2000	
11110	25/16 mm	0.012	10	2000	
11112	25/20 mm	0.013	10	1500	
11114	32/20 mm	0.016	5	1000	
11116	32/25 mm	0.021	5	1000	
11118	40/20 mm	0.026	5	750	
11120	40/25 mm	0.034	5	600	
11122	40/32 mm	0.035	5	600	
11124	50/20 mm	0.044	5	500	
11126	50/25 mm	0.042	5	500	
11128	50/32 mm	0.052	5	350	
11130	50/40 mm	0.057	5	300	
11131	63/20 mm	0.074	1	200	
11132	63/25 mm	0.069	1	200	
11134	63/32 mm	0.084	1	200	
11136	63/40 mm	0.092	1	200	
11138	63/50 mm	0.116	1	150	
11139	75/40 mm	0.110	1	150	
11140	75/50 mm	0.109	1	100	
11142	75/63 mm	0.131	1	100	
11143	75/20 mm	0.132	1	200	
11144	75/25 mm	0.156	1	200	
11145	75/32 mm	0.182	1	150	
11151	90/50 mm	0.207	1	100	
11152	90/63 mm	0.244	1	75	
11153	90/75 mm	0.288	1	60	
11155	110/63 mm	0.349	1	50	
11157	110/75 mm	0.404	1	50	
11159	110/90 mm	0.531	1	40	
11161	125/75 mm	0.531	1	35	
11163	125/90 mm	0.531	1	35	
11165	125/110 mm	0.819	1	25	
11176	SDR 7.4 - 160/125 mm	0.814	1	20	
11177	SDR 11 - 160/125 mm	0.980	1	20	
11184	SDR 7.4 - 200/160 mm	1.570	1	12	
11185	SDR 11 - 200/160 mm	1.170	1	12	
11190	SDR 7.4 - 250/200 mm	3.210	1	5	
11191	SDR 11 - 250/200 mm	2.330	1	5	

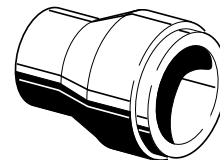

Fittings

fusiotherm®-reducing socket

female / female

Art.-No.	Dimension	kg / pc	Packing unit m / pc	Box unit m / pc	Piece
11238	63 / 50 mm	0.117	1	100	
11242	75 / 63 mm	0.181	1	80	
11253	90 / 75 mm	0.285	1	50	

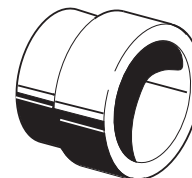

fusiotherm®-elbow 90°

Art.-No.	Dimension	kg / pc	Packing unit m / pc	Box unit m / pc	Piece
12106	16 mm	0.011	10	2000	
12108	20 mm	0.018	10	1200	
12110	25 mm	0.025	10	800	
12112	32 mm	0.041	5	400	
12114	40 mm	0.071	5	250	
12116	50 mm	0.161	5	125	
12118	63 mm	0.277	1	75	
12120	75 mm	0.447	1	50	
12122	90 mm	0.802	1	25	
12124	110 mm	1.412	1	15	
12126	125 mm	1.964	1	10	
12130	SDR 7.4 - 160 mm	2.603	1	8	
12131	SDR 11 - 160 mm	1.959	1	8	
12134	SDR 7.4 - 200 mm	11.690	1	16	
12135	SDR 11 - 200 mm	8.140	1	16	
12138	SDR 7.4 - 250 mm	26.000	1	7	
12139	SDR 11 - 250 mm	18.000	1	7	

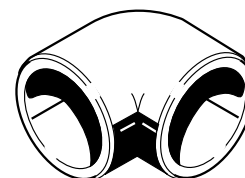

fusiotherm®-elbow 90°

female / male

Art.-No.	Dimension	kg / pc	Packing unit m / pc	Box unit m / pc	Piece
12306	16 mm	0.011	10	2000	
12308	20 mm	0.018	10	1200	
12310	25 mm	0.025	10	800	
12312	32 mm	0.041	5	500	
12314	40 mm	0.071	5	300	

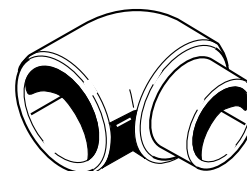

Fittings

fusiotherm® -elbow 45°

Art.-No.	Dimension	kg / pc	Packing unit m / pc	Box unit m / pc	Piece
12506	16 mm	0.009	10	2000	
12508	20 mm	0.014	10	1500	
12510	25 mm	0.019	10	1000	
12512	32 mm	0.035	5	500	
12514	40 mm	0.054	5	300	
12516	50 mm	0.115	5	150	
12518	63 mm	0.221	1	75	
12520	75 mm	0.343	1	60	
12522	90 mm	0.558	1	30	
12524	110 mm	0.995	1	20	
12526	125 mm	1.278	1	15	
12530	SDR 7.4 - 160 mm	1.898	1	10	
12531	SDR 11 - 160 mm	1.376	1	10	
12534	SDR 7.4 - 200 mm	8.180	1	2	
12535	SDR 11 - 200 mm	5.740	1	2	
12538	SDR 7.4 - 250 mm	2.800	1	10	
12539	SDR 11 - 250 mm	13.000	1	10	

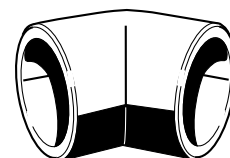
**fusiotherm®** -elbow 45°

female / male

Art.-No.	Dimension	kg / pc	Packing unit m / pc	Box unit m / pc	Piece
12708	20 mm	0.014	10	1500	
12710	25 mm	0.018	10	1000	
12712	32 mm	0.036	5	500	
12714	40 mm	0.057	5	300	

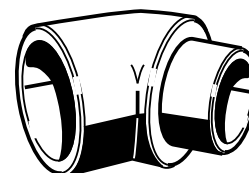

Fittings

fusiotherm®-tee

Art.-No.	Dimension	kg / pc	Packing unit m / pc	Box unit m / pc	Piece
13106	16 mm	0.015	10	1500	
13108	20 mm	0.024	10	1000	
13110	25 mm	0.033	10	500	
13112	32 mm	0.061	5	300	
13114	40 mm	0.089	5	200	
13116	50 mm	0.205	5	100	
13118	63 mm	0.368	1	50	
13120	75 mm	0.556	1	30	
13122	90 mm	0.968	1	25	
13124	110 mm	1.718	1	14	
13126	125 mm	2.671	1	8	
13130	SDR 7.4 - 160 mm	3.652	1	5	
13131	SDR 11 - 160 mm	2.772	1	5	
13134	SDR 7.4 - 200 mm	3.652	1	2	
13135	SDR 11 - 200 mm	6.870	1	2	
13138	SDR 7.4 - 250 mm	22.000	1	8	
13139	SDR 11 - 250 mm	16.000	1	8	

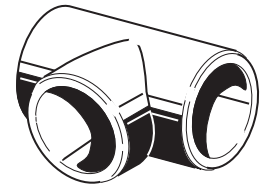

fusiotherm®-reducing tee

Art.-No.	Dimension	kg / pc	Packing unit m / pc	Box unit m / pc	Piece
13506	20 x 16 x 16 mm	0.026	10	1000	
13508	20 x 16 x 20 mm	0.025	10	1000	
13510	20 x 20 x 16 mm	0.025	10	1000	
13511	20 x 25 x 20 mm	0.041	10	500	
13512	25 x 16 x 16 mm	0.043	10	500	
13514	25 x 16 x 20 mm	0.041	10	500	
13516	25 x 16 x 25 mm	0.038	10	500	
13520	25 x 20 x 20 mm	0.040	10	500	
13522	25 x 20 x 25 mm	0.036	10	500	
13528	32 x 16 x 32 mm	0.055	5	300	
13532	32 x 20 x 20 mm	0.082	5	300	
13534	32 x 20 x 32 mm	0.053	5	300	
13540	32 x 25 x 32 mm	0.064	5	300	
13542	40 x 20 x 40 mm	0.092	5	200	
13544	40 x 25 x 40 mm	0.089	5	200	
13546	40 x 32 x 40 mm	0.106	5	200	
13547	50 x 20 x 50 mm	0.184	5	100	

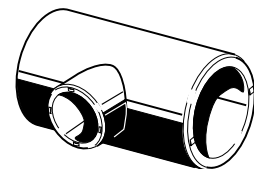

Fittings

fusiotherm®-reducing tee

Art.-No.	Dimension	kg / pc	Packing unit m / pc	Box unit m / pc	Piece
13548	50 x 25 x 50 mm	0.192	5	100	
13550	50 x 32 x 50 mm	0.184	5	100	
13551	50 x 40 x 50 mm	0.224	5	100	
13552	63 x 20 x 63 mm	0.334	1	50	
13554	63 x 25 x 63 mm	0.339	1	50	
13556	63 x 32 x 63 mm	0.344	1	50	
13558	63 x 40 x 63 mm	0.333	1	50	
13560	63 x 50 x 63 mm	0.400	1	50	
13561	75 x 20 x 75 mm	0.537	1	35	
13562	75 x 25 x 75 mm	0.527	1	35	
13564	75 x 32 x 75 mm	0.524	1	35	
13566	75 x 40 x 75 mm	0.537	1	35	
13568	75 x 50 x 75 mm	0.523	1	35	
13570	75 x 63 x 75 mm	0.550	1	35	
13576	90 x 32 x 90 mm	0.902	1	25	
13578	90 x 40 x 90 mm	0.892	1	25	
13580	90 x 50 x 90 mm	1.006	1	25	
13582	90 x 63 x 90 mm	0.915	1	25	
13584	90 x 75 x 90 mm	1.040	1	25	
13586	110 x 63 x 110 mm	1.673	1	15	
13588	110 x 75 x 110 mm	1.627	1	15	
13590	110 x 90 x 110 mm	1.647	1	15	
13592	125 x 75 x 125 mm	1.626	1	8	
13594	125 x 90 x 125 mm	1.647	1	8	
13596	125 x 110 x 125 mm	2.629	1	8	
13600	SDR 7.4 - 160 x 75 x 160 mm	4.414	1	4	
13601	SDR 11 - 160 x 75 x 160 mm	3.140	1	4	
13602	SDR 7.4 - 160 x 90 x 160 mm	4.515	1	4	
13603	SDR 11 - 160 x 90 x 160 mm	3.176	1	4	
13608	SDR 7.4 - 200 x 75 x 200 mm	7.110	1	1	
13609	SDR 11 - 200 x 75 x 200 mm	5.284	1	1	
13610	SDR 7.4 - 200 x 90 x 200 mm	7.540	1	1	
13611	SDR 11 - 200 x 90 x 200 mm	5.168	1	1	
13612	SDR 7.4 - 200 x 110 x 200 mm	7.325	1	1	
13613	SDR 11 - 200 x 110 x 200 mm	5.648	1	1	
13614	SDR 7.4 - 200 x 125 x 200 mm	7.645	1	1	
13615	SDR 11 - 200 x 125 x 200 mm	5.786	1	1	
13624	SDR 7.4 - 250 x 75 x 250 mm	16.600	1	12	
13625	SDR 11 - 250 x 75 x 250 mm	12.000	1	12	
13626	SDR 7.4 - 250 x 90 x 250 mm	16.800	1	12	
13627	SDR 11 - 250 x 90 x 250 mm	12.000	1	12	
13628	SDR 7.4 - 250 x 110 x 250 mm	16.800	1	12	
13629	SDR 11 - 250 x 110 x 250 mm	13.000	1	12	
13630	SDR 7.4 - 250 x 125 x 250 mm	17.000	1	12	
13631	SDR 11 - 250 x 125 x 250 mm	12.000	1	12	

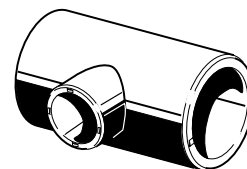

Fittings

fusiotherm®-cross

Art.-No.	Dimension	kg / pc	Packing unit m / pc	Box unit m / pc	Piece
13708	20 mm	0.026	10	500	
13710	25 mm	0.036	10	500	
13712	32 mm	0.067	5	250	
13714	40 mm	0.105	5	150	

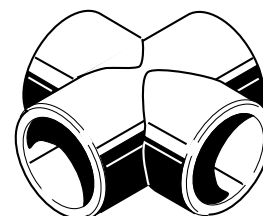

fusiotherm®-end cap

Art.-No.	Dimension	kg / pc	Packing unit m / pc	Box unit m / pc	Piece
14106	16 mm	0.009	10	2000	
14108	20 mm	0.011	10	2000	
14110	25 mm	0.009	10	1500	
14112	32 mm	0.023	5	1000	
14114	40 mm	0.042	5	500	
14116	50 mm	0.079	5	300	
14118	63 mm	0.145	1	150	
14120	75 mm	0.240	1	100	
14122	90 mm	0.379	1	75	
14124	110 mm	0.617	1	40	
14126	125 mm	0.857	1	30	
14130	SDR 7.4 - 160 mm	0.857	1	30	
14131	SDR 11 - 160 mm	0.752	1	30	
14134	SDR 7.4 - 200 mm	1.390	1	24	
14135	SDR 11 - 200 mm	1.000	1	24	
14138	SDR 7.4 - 250 mm	2.550	1	10	
14139	SDR 11 - 250 mm	2.010	1	10	

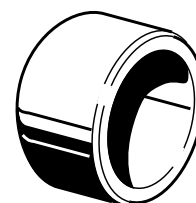

fusiotherm®-cross over fitting

Art.-No.	Dimension	kg / pc	Packing unit m / pc	Box unit m / pc	Piece
16106	16 mm	0.039	10	600	
16108	20 mm	0.065	10	400	
16110	25 mm	0.096	10	250	
16112	32 mm	0.154	5	120	



Fittings

fusiotherm®-weld-in saddle

Art.-No.	Dimension	kg / pc	Packing unit m / pc	Box unit m / pc	Piece
15156	40/20 mm	0.015	5	1000	
15158	40/25 mm	0.017	5	1000	
15160	50/20 mm	0.018	5	1000	
15162	50/25 mm	0.019	5	1000	
15164	63/20 mm	0.018	5	1000	
15166	63/25 mm	0.019	5	750	
15168	63/32 mm	0.026	5	750	
15170	75/20 mm	0.018	5	1000	
15172	75/25 mm	0.019	5	750	
15174	75/32 mm	0.027	5	750	
15175	75/40 mm	0.048	5	400	
15176	90/20 mm	0.019	5	1000	
15178	90/25 mm	0.019	5	1000	
15180	90/32 mm	0.027	5	750	
15181	90/40 mm	0.048	5	500	
15182	110/20 mm	0.019	5	1000	
15184	110/25 mm	0.020	5	1000	
15186	110/32 mm	0.028	5	750	
15188	110/40 mm	0.049	5	450	
15189	110/50 mm	0.029	5	200	
15190	125/20 mm	0.019	5	1000	
15192	125/25 mm	0.021	5	1000	
15194	125/32 mm	0.030	5	750	
15196	125/40 mm	0.051	5	450	
15197	125/50 mm	0.029	5	200	
15198	125/63 mm	0.029	5	125	
15206	160/20 mm	0.025	5	700	
15208	160/25 mm	0.026	5	700	
15210	160/32 mm	0.034	5	500	
15212	160/40 mm	0.057	5	300	
15214	160/50 mm	0.092	5	200	
15216	160/63 mm	0.156	5	120	
15228	200-250/20 mm	0.195	5	100	
15229	200-250/25 mm	0.210	5	100	
15230	200-250/32 mm	0.310	5	50	
15231	200/40 mm	0.485	5	200	
15232	200/50 mm	0.865	5	200	
15233	200/63 mm	1.460	5	120	
15251	250/40 mm	5.100	5	30	
15252	250/50 mm	8.900	5	30	
15253	250/63 mm	15.000	5	120	

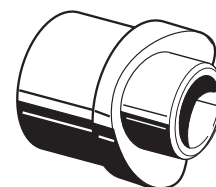

With weld-on surface and additional weld-in socket for the fusion with the inner pipe wall

The necessary welding tools for the **fusiotherm®**-weld-in saddles are described on page 171 and 172

Weld-in saddle tools Art.-No. 50614 - 50680

Chamfering tool (only for stable composite pipes) Art.-No. 50910, 50912, 50914

fusiotherm®-drill
Art.-No. 50940, 50941, 50942, 50944, 50946, 50948

Fittings

fusiotherm®-flange adapter

with gasket

Art.-No.	Dimension	kg / pc	Packing unit m / pc	Box unit m / pc	Piece
15512	32 mm	0.031	1	500	
15514	40 mm	0.044	1	250	
15516	50 mm	0.061	1	200	
15518	63 mm	0.100	1	200	
15520	75 mm	0.143	1	100	
15522	90 mm	0.252	1	60	
15524	110 mm	0.327	1	50	
15526	125 mm*	1.310	1	16	
15527	125 mm	1.310	1	25	
15530	SDR 7.4 - 160 mm	1.163	1	16	
15531	SDR 11 - 160 mm	0.954	1	16	
15534	SDR 7.4 - 200 mm	2.292	1	6	
15535	SDR 11 - 200 mm	1.957	1	6	
15538	SDR 7.4 - 250 mm	3.298	1	4	
15539	SDR 11 - 250 mm	2.717	1	4	

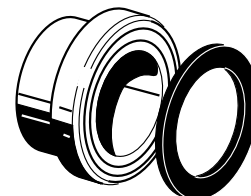

*only applicable with fitting

fusiotherm®-plastic coated steel flange

Art.-No.	Dimension	no. of holes	hole circle	kg / pc	Packing unit m / pc	Box unit m / pc	Piece
15712	32 mm for Art.-No. 15512	4	85 mm	0.458	1	100	
15714	40 mm for Art.-No. 15514	4	100 mm	0.708	1	80	
15716	50 mm for Art.-No. 15516	4	110 mm	0.778	1	60	
15718	63 mm for Art.-No. 15518	4	125 mm	0.910	1	50	
15720	75 mm for Art.-No. 15520	4	145 mm	1.160	1	40	
15722	90 mm for Art.-No. 15522	8	160 mm	1.390	1	40	
15724	110 mm for Art.-No. 15524/15526	8	180 mm	1.492	1	30	
15726	125 mm for Art.- No. 15527	8	210 mm	1.492	1	20	
15730	160 mm for Art.-No. 15530/15531	8	240 mm	3.628	1	16	
15734	200 mm for Art.-No. 15534/15535	8	295 mm	4.750	1	4	
15738	250 mm for Art.-No. 15538/15539	12	350 mm	7.096	1	4	

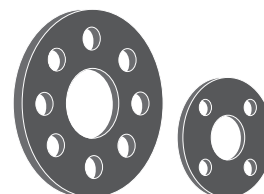

Fittings

fusiotherm[®]-coupling screw joint

Art.-No.	Dimension	kg / pc	Packing unit m / pc	Box unit m / pc	Piece
15812	32 mm	0.498	1	100	
15814	40 mm	0.842	1	70	
15816	50 mm	0.945	1	50	
15818	63 mm	1.541	1	25	
15820	75 mm	2.040	1	15	

with 2 flange adapters including gasket

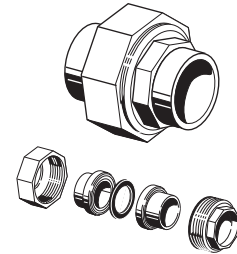

fusiotherm[®]-PP-plastic screw joint

Art.-No.	Dimension	kg / pc	Packing unit m / pc	Box unit m / pc	Piece
15838	20 mm	0.036	10	300	
15840	25 mm	0.059	10	250	
15842	32 mm	0.088	5	200	
15844	40 mm	0.134	5	150	
15846	50 mm	0.169	5	100	
15848	63 mm	0.292	1	60	
15850	75 mm		1		

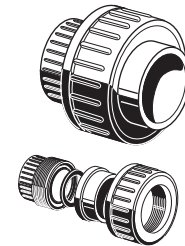

fusiotherm[®]-electrofusion socket

Art.-No.	Dimension	kg / pc	Packing unit m / pc	Box unit m / pc	Piece
17208	20 mm	0.044	1	500	
17210	25 mm	0.053	1	350	
17212	32 mm	0.072	1	300	
17214	40 mm	0.098	1	200	
17216	50 mm	0.139	1	130	
17218	63 mm	0.225	1	75	
17220	75 mm	0.342	1	45	
17222	90 mm	0.494	1	30	
17224	110 mm	0.815	1	22	
17226	125 mm	1.093	1	16	
17230*	160 mm	1.769	1	10	

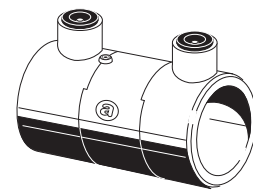

Tools:

fusiotherm[®]-electrofusion device (Art.-No. 50175)

fusiotherm[®]-peeling tool (Art.-No. 50558-50580)

On working with **fusiotherm**[®]-stabi composite pipes a special peeling tool has to be used.

*Cannot be used in connection with 160 mm UV-pipes. (Art. No. 70780 and 2070180)

Armature connections, accessories and fittings

fusiotherm®-back plate elbow

Art.-No.	Dimension	kg / pc	Packing unit m / pc	Box unit m / pc	Piece
20106	16 mm x 1/2" f	0.085	10	200	
20108	20 mm x 1/2" f	0.085	10	200	
20110	20 mm x 3/4" f	0.111	10	150	
20112	25 mm x 3/4" f	0.111	10	150	
20113	25 mm x 1/2" f	0.091	10	200	

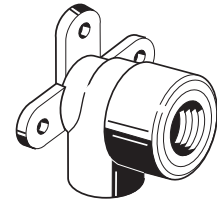

Mounting plate

galvanized; to fix back plate elbows as double connection

Art.-No.	Dimension	kg / pc	Packing unit m / pc	Box unit m / pc	Piece
60010	220/150/80 mm	0.221	1	250	

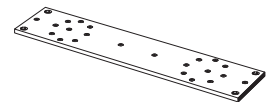

not suitable for connection with sound insulation plate (Art.-No. 79080).

We recommend mounting rail Art.-No. 79090.

Mounting rail

galvanized; to fix back plate elbows including 2 fixing plates and 4 screws

Art.-No.	Dimension	kg / pc	Packing unit m / pc	Box unit m / pc	Piece
79090	length = 560 mm	0.527	1	100	

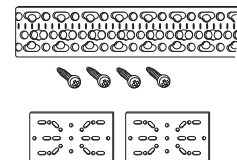

fusiotherm®-sound isolation cover

for fusiotherm®-back plate elbow 1/2"

Art.-No.	Dimension	kg / pc	Packing unit m / pc	Box unit m / pc	Piece
20120	Thickness approx. 5 mm	0.002	1	60	

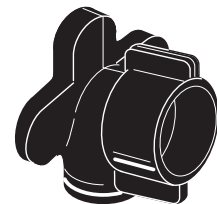

aquatherm® SHT-sound isolation plate

for fusiotherm®- and aquatherm® SHT-back plate elbow

Art.-No.	Dimension	kg / pc	Packing unit m / pc	Box unit m / pc	Piece
79080		0.058	2	50	

suitable for mounting rail Art.-No. 79090

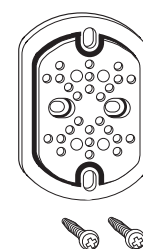

Armature connections and accessories

Mounting rail (double and single)

Art.-No.	Dimension	kg / pc	Packing unit m / pc	Box unit m / pc	Piece
79095	double	0.412	2	20	
79096	single	0.235	2	20	

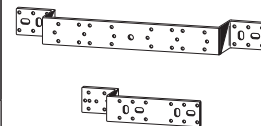

galvanized, for fixing of back plate elbows

fusiotherm®-dry construction wall fitting

Art.-No.	Dimension	kg / pc	Packing unit m / pc	Box unit m / pc	Piece
20114	1/2"	0.126	10	300	

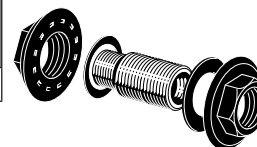

fusiotherm®-back plate elbow for dry construction

Art.-No.	Dimension	kg / pc	Packing unit m / pc	Box unit m / pc	Piece
20156	16 mm x 1/2" f	0.084	10	250	
20158	20 mm x 1/2" f	0.081	10	200	

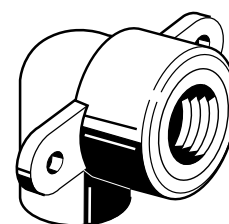

fusiotherm®-transition piece

with counternut, gasket and tension washer

Art.-No.	Dimension	kg / pc	Packing unit m / pc	Box unit m / pc	Piece
20204	20 mm x 1/2" f x 3/4" m	0.204	10	200	

e.g. for connection of a cistern or application with mounting plate (Art.-No. 60110-60115)

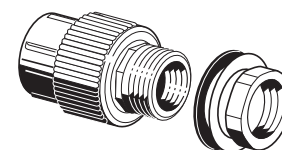

fusiotherm®-transition elbow

with counternut, gasket and tension washer

Art.-No.	Dimension	kg / pc	Packing unit m / pc	Box unit m / pc	Piece
20206	16 mm x 1/2" f x 3/4" m	0.204	10	200	
20208	20 mm x 1/2" f x 3/4" m	0.200	10	200	
20209	25 mm x 1/2" f x 3/4" m	0.206	10	150	

e.g. for connection of a cistern or application with mounting plate (Art.-No. 60110-60115)

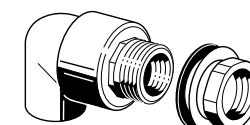

Accessories and transition pieces

fusiotherm®-plug for pressure tests

with gasket

Art.-No.	Dimension	kg/ pc	Packing unit m/ pc	Box unit m/ pc	Piece
50708	1/2" m	0.022	1	1000	
50710	3/4" m	0.027	1	700	

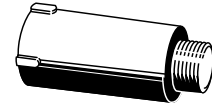

fusiotherm®-assembling jig

as water level with 2 plugs 1/2"

Art.-No.	Dimension	kg/ pc	Packing unit m/ pc	Box unit m/ pc	Piece
50700	-	0.252	1	75	

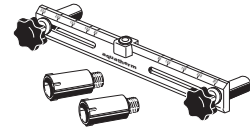

fusiotherm®-mounting unit

double

Art.-No.	Dimension	kg/ pc	Packing unit m/ pc	Box unit m/ pc	Piece
60110	80/ 100/ 150 mm	0.642	1	25	

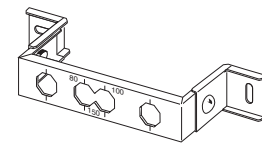

fusiotherm®-mounting unit

single

Art.-No.	Dimension	kg/ pc	Packing unit m/ pc	Box unit m/ pc	Piece
60115		0.275	1	100	

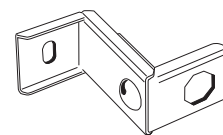

Accessories and transition pieces

fusiotherm®-mounting unit

with two fusiotherm®-transition elbows (Art.-No. 20208)

Art.-No.	Dimension	kg / pc	Packing unit m / pc	Box unit m / pc	Piece
60150		0.642	1	25	

with conternut, gasket and tension washer

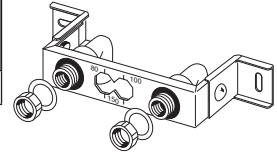

fusiotherm®-mounting unit

with one fusiotherm®-transition elbows (Art.-No. 20208)

Art.-No.	Dimension	kg / pc	Packing unit m / pc	Box unit m / pc	Piece
60155		0.474	1	80	

with conternut, gasket and tension washer

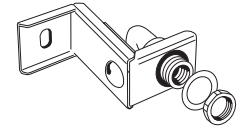

fusiotherm®-transition elbow

for dry construction

Art.-No.	Dimension	kg / pc	Packing unit m / pc	Box unit m / pc	Piece
20210	20 mm x 1/2" f x 3/4" m	0.221	10	200	

with 30 mm thread, conternut, gasket and tension washer

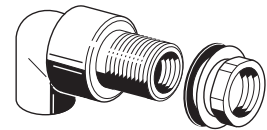

Transition pieces

fusiotherm®-transition piece with female thread

round

Art.-No.	Dimension	kg / pc	Packing unit m / pc	Box unit m / pc	Piece
21006	16 mm x 1/2" f	0.071	10	400	
21008	20 mm x 1/2" f	0.070	10	400	
21010	20 mm x 3/4" f	0.090	10	300	
21011	25 mm x 1/2" f	0.071	10	400	
21012	25 mm x 3/4" f	0.086	10	300	
21013	32 mm x 3/4" f	0.093	5	200	

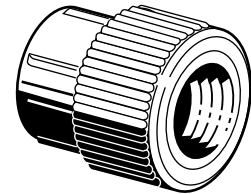

fusiotherm®-transition piece with female thread

hex shaped threaded transition

Art.-No.	Dimension	kg / pc	Packing unit m / pc	Box unit m / pc	Piece
21106	16 mm x 1/2" f	0.087	10	400	
21108	20 mm x 1/2" f	0.087	10	400	
21110	20 mm x 3/4" f	0.113	10	300	
21111	25 mm x 1/2" f	0.087	10	300	
21112	25 mm x 3/4" f	0.111	10	300	
21113	32 mm x 3/4" f	0.114	5	150	
21114	32 mm x 1" f	0.239	5	150	
21115	40 mm x 1" f	0.246	5	125	
21116	40 mm x 1 1/4" f	0.383	5	80	
21117	50 mm x 1 1/4" f	0.401	5	75	
21118	50 mm x 1 1/2" f	0.445	5	60	
21119	63 mm x 1 1/2" f	0.468	1	50	
21120	63 mm x 2" f	0.650	1	35	
21122	75 mm x 2" f	0.671	1	25	

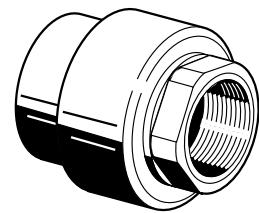

fusiotherm®-transition piece with male thread

round, self sealing

Art.-No.	Dimension	kg / pc	Packing unit m / pc	Box unit m / pc	Piece
21258	20 mm x 1/2" m	0.089	10	400	
21261	25 mm x 1/2" m	0.091	10	350	
21262	25 mm x 3/4" m	0.099	10	350	

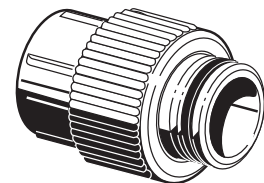

Note:

fusiotherm®-metal compound fittings are manufactured from **fusiolen®** PP-R and brass. Metal inserts, without hex shaped spanner flat, with 1/2" and 3/4" F are also available in stainless steel / price on request!

Transition pieces

fusiotherm®-transition piece

round

Art.-No.	Dimension	kg / pc	Packing unit m / pc	Box unit m / pc	Piece
21206	16 mm x 1/2" m	0.098	10	400	
21208	20 mm x 1/2" m	0.096	10	400	
21210	20 mm x 3/4" m	0.108	10	300	
21211	25 mm x 1/2" m	0.099	10	300	
21212	25 mm x 3/4" m	0.108	10	350	
21213	32 mm x 3/4" m	0.113	5	200	

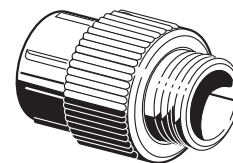

fusiotherm®-transition piece with male thread

with hex shaped threaded transition

Art.-No.	Dimension	kg / pc	Packing unit m / pc	Box unit m / pc	Piece
21306	16 mm x 1/2" m	0.120	10	300	
21308	20 mm x 1/2" m	0.118	10	300	
21310	20 mm x 3/4" m	0.129	10	300	
21312	25 mm x 3/4" m	0.128	10	300	
21314	32 mm x 1" m	0.244	5	125	
21316	32 mm x 1 1/4" m	0.357	5	100	
21317	40 mm x 1" m	0.250	5	100	
21318	40 mm x 1 1/4" m	0.364	5	80	
21319	50 mm x 1 1/4" m	0.391	5	75	
21320	50 mm x 1 1/2" m	0.480	5	60	
21321	63 mm x 1 1/2" m	0.523	1	40	
21322	63 mm x 2" m	0.705	1	40	
21323	75 mm x 2" m	0.753	1	25	
21324	75 mm x 2 1/2" m	1.024	1	25	
21325	90 mm x 3" m	1.530	1	20	
21327	110 mm x 4" m	2.816	1	8	

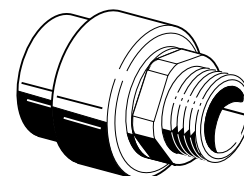

fusiotherm®-transition piece with male thread

self-sealing, with hex shaped threaded transition male/male

Art.-No.	Dimension	kg / pc	Packing unit m / pc	Box unit m / pc	Piece
21355	20 mm x 1/2" m	0.106	10	300	

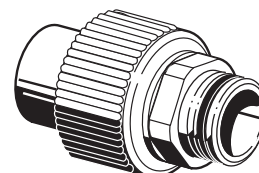

fusiotherm®-transition piece with male thread

self-sealing, with hex shaped threaded transition

Art.-No.	Dimension	kg / pc	Packing unit m / pc	Box unit m / pc	Piece
21356	16 mm x 1/2" m	0.111	10	300	
21358	20 mm x 1/2" m	0.111	10	300	

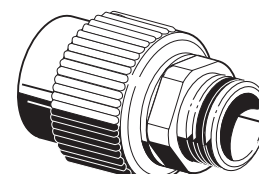

Transition pieces

fusiotherm®-transition elbow with female thread

Art.-No.	Dimension	kg / pc	Packing unit m / pc	Box unit m / pc	Piece
23006	16 mm x 1/2" f	0.082	10	300	
23008	20 mm x 3/4" f	0.108	10	250	
23010	20 mm x 1/2" f	0.081	10	300	
23012	25 mm x 3/4" f	0.106	10	200	
23014	25 mm x 1/2" f	0.087	10	250	
23016	32 mm x 3/4" f	0.110	5	150	
23018	32 mm x 1" f	0.260	5	100	

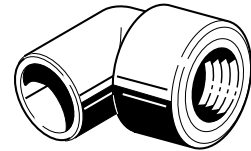

fusiotherm®-transition elbow with female thread

female / male

Art.-No.	Dimension	kg / pc	Packing unit m / pc	Box unit m / pc	Piece
23208	a 20 mm x 1/2" f	0.080	10	350	

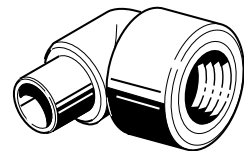

fusiotherm®-transition elbow with male thread

Art.-No.	Dimension	kg / pc	Packing unit m / pc	Box unit m / pc	Piece
23504	16 mm x 1/2" m	0.107	10	400	
23506	20 mm x 1/2" m	0.109	10	300	
23508	20 mm x 3/4" m	0.128	10	200	
23510	25 mm x 3/4" m	0.124	10	250	
23512	32 mm x 3/4" m	0.133	5	150	
23514	32 mm x 1" m	0.260	5	100	

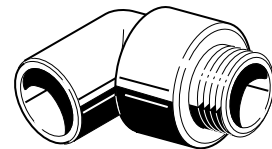

fusiotherm®-threaded branch tee with female thread

Art.-No.	Dimension	kg / pc	Packing unit m / pc	Box unit m / pc	Piece
25004	16 x 1/2" f x 16 mm	0.090	10	250	
25006	20 x 1/2" f x 20 mm	0.088	10	250	
25008	20 x 3/4" f x 20 mm	0.120	10	170	
25010	25 x 1/2" f x 25 mm	0.093	10	200	
25012	25 x 3/4" f x 25 mm	0.116	10	150	
25014	32 x 3/4" f x 32 mm	0.118	5	100	
25016	32 x 1" f x 32 mm	0.272	5	80	
25022	50 x 1" f x 50 mm	0.433	5	40	

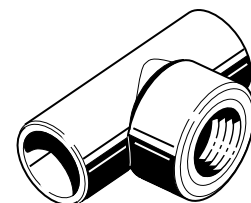

Transition pieces and threaded adapter

fusiotherm®-threaded branch tee with male thread

Art.-No.	Dimension	kg / pc	Packing unit m / pc	Box unit m / pc	Piece
25506	20 x 1/2" m x 20 mm	0.115	10	200	

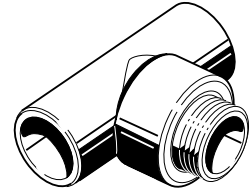

fusiotherm®-transition coupling with male thread

with union nut and welding socket

Art.-No.	Dimension	kg / pc	Packing unit m / pc	Box unit m / pc	Piece
26608	20 mm x 1/2" m	0.166	1	250	
26610	25 mm x 3/4" m	0.293	1	150	
26612	32 mm x 1" m	0.381	1	150	
26614	40 mm x 1 1/4" m	0.619	1	80	
26616	50 mm x 1 1/2" m	0.694	1	60	
26618	63 mm x 2" m	1.166	1	35	

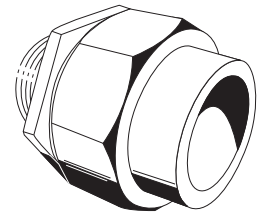

fusiotherm®-transition coupling with female thread

with union nut and welding socket

Art.-No.	Dimension	kg / pc	Packing unit m / pc	Box unit m / pc	Piece
26638	20 mm x 1/2" f	0.123	1	300	
26640	25 mm x 3/4" f	0.205	1	120	
26642	32 mm x 1" f	0.289	1	100	
26644	40 mm x 1 1/4" f	0.425	1	100	
26646	50 mm x 1 1/2" f	0.607	1	60	
26648	63 mm x 2" f	0.933	1	50	

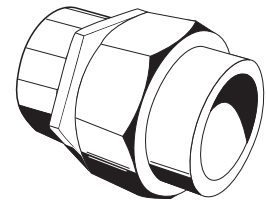

fusiotherm®-loose nut adapter

length: 100 mm. with gasket

Art.-No.	Dimension	kg / pc	Packing unit m / pc	Box unit m / pc	Piece
26708	20 mm x nut R 1"	0.083	1	150	
26710	25 mm x nut R 1 1/4"	0.117	1	125	
26712	32 mm x nut R 1 1/2"	0.160	1	100	
26714	40 mm x nut R 2"	0.256	1	75	
26716	50 mm x nut R 2 1/4"	0.436	1	60	
26718	63 mm x nut R 2 3/4"	0.541	1	40	
26720	75 mm x nut R 3 1/2"	0.918	1	30	
26722	90 mm x nut R 4"	1.238	1	20	

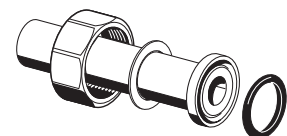

Threaded adapter and counter parts

fusiotherm®-water meter nut adapter

with gasket

Art.-No.	Dimension	kg / pc	Packing unit m / pc	Box unit m / pc	Piece
26808	20 mm x nut R 3/4"	0.151	1	250	
26810	25 mm x nut R 3/4"	0.151	1	250	
26812	32 mm x nut R 3/4"	0.162	1	200	

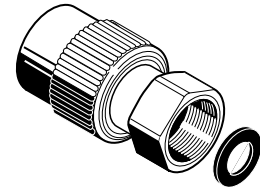

fusiotherm®-nut adapter

ISO-standard

Art.-No.	Dimension	kg / pc	Packing unit m / pc	Box unit m / pc	Piece
27010	20 mm x nut R 1"	0.182	10	300	
27011	25 mm x nut R 1"	0.185	10	300	
27012	25 mm x nut R 1 1/4"	0.253	10	250	
27013	32 mm x nut R 1 1/4"	0.272	5	175	
27014	32 mm x nut R 1 1/2"	0.437	5	125	
27015	40 mm x nut R 1 1/2"	0.452	5	100	
27016	40 mm x nut R 2"	0.705	5	70	
27017	50 mm x nut R 2"	0.723	5	70	
27018	50 mm x nut R 2 1/4"	0.919	5	50	
27019	63 mm x nut R 2 1/4"	0.951	1	45	
27020	63 mm x nut R 2 3/4"	1.236	1	30	
27021	75 mm x nut R 2 3/4"	1.260	1	30	
27022	75 mm x nut R 3 1/2"	1.832	1	30	

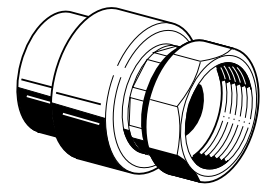

fusiotherm®-counterpart

with welding socket and male thread for ISO-standard adapter

Art.-No.	Dimension	kg / pc	Packing unit m / pc	Box unit m / pc	Piece
27310	20 mm x 1" m	0.149	10	300	
27311	25 mm x 1" m	0.150	10	300	
27312	25 mm x 1 1/4" m	0.222	10	250	
27313	32 mm x 1 1/4" m	0.226	5	175	
27314	32 mm x 1 1/2" m	0.404	5	125	
27315	40 mm x 1 1/2" m	0.409	5	125	
27316	40 mm x 2" m	0.604	5	70	
27317	50 mm x 2" m	0.630	5	70	
27318	50 mm x 2 1/4" m	0.665	5	50	
27319	63 mm x 2 1/4" m	0.694	1	45	
27320	63 mm x 2 3/4" m	1.071	1	30	
27321	75 mm x 2 3/4" m	1.095	1	30	
27322	75 mm x 3 1/2" m	1.442	1	30	

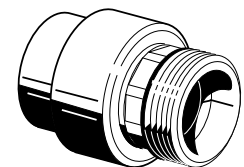

Threaded adapter and counter parts

fusiotherm®-brass counterpart

with female thread, for ISO-standard adapter / loose nut adapter

Art.-No.	Dimension	kg / pc	Packing unit m / pc	Box unit m / pc	Piece
27510	1" m x 1/2" f	0.063	10	400	
27512	1 1/4" m x 3/4" f	0.120	10	200	
27514	1 1/2" m x 1" f	0.173	5	125	
27516	2" m x 1 1/4" f	0.257	5	75	
27518	2 1/4" m x 1 1/2" f	0.335	5	60	
27520	2 3/4" m x 2" f	0.508	1	35	
27522	3 1/2" m x 2 1/2" f	0.808	1	25	
27524	4" m x 3" f	0.946	1	25	

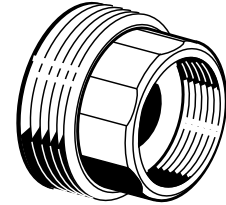

fusiotherm®- brass counterpart

with male thread, for ISO-standard adapter / loose nut adapter

Art.-No.	Dimension	kg / pc	Packing unit m / pc	Box unit m / pc	Piece
27710	1" m x 1/2" m	0.108	10	250	
27712	1 1/4" m x 3/4" m	0.190	10	140	
27714	1 1/2" m x 1" m	0.248	5	100	
27716	2" m x 1 1/4" m	0.442	5	60	
27718	2 1/4" m x 1 1/2" m	0.471	5	50	
27720	2 3/4" m x 2" m	0.808	1	25	
27722	3 1/2" m x 2 1/2" m	1.244	1	15	
27724	4" m x 3" m	1.404	1	10	

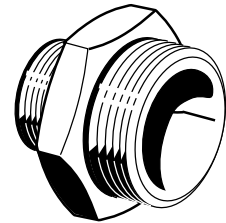

Note:

fusiotherm®-metal compound fittings are manufactured from **fusiolen®** PP-R and brass. Metal inserts, without hex shaped spanner flat, with 1/2" and 3/4" F are also available in stainless steel / price on request!

Weld-in saddle

fusiotherm®-weld-in saddle with female thread

Art.-No.	Dimension	kg / pc	Packing unit m / pc	Box unit m / pc	Piece
28214	40/25 mm x 1/2" f	0.087	5	300	
28216	50/25 mm x 1/2" f	0.088	5	300	
28218	63/25 mm x 1/2" f	0.088	5	300	
28220	75/25 mm x 1/2" f	0.088	5	300	
28222	90/25 mm x 1/2" f	0.088	5	300	
28224	110/25 mm x 1/2" f	0.088	5	300	
28226	125/25 mm x 1/2" f	0.091	5	250	
28230	160/25 mm x 1/2" f	0.095	5	250	
28232	200-250/25 mm x 1/2" f	0.091	5	50	
28234	40/25 mm x 3/4" f	0.107	5	300	
28236	50/25 mm x 3/4" f	0.108	5	300	
28238	63/25 mm x 3/4" f	0.111	5	300	
28240	75/25 mm x 3/4" f	0.110	5	300	
28242	90/25 mm x 3/4" f	0.109	5	300	
28244	110/25 mm x 3/4" f	0.110	5	300	
28246	125/25 mm x 3/4" f	0.111	5	300	
28250	160/25 mm x 3/4" f	0.112	5	250	
28254	200-250/25 mm x 3/4" f	0.111	5	250	
28260	75/32 mm x 1" f	0.088	5	125	
28262	90/32 mm x 1" f	0.088	5	125	
28264	110/32 mm x 1" f	0.237	5	125	
28266	125/32 mm x 1" f	0.237	5	125	
28270	160/32 mm x 1" f	0.244	5	125	
28274	200-250/32 mm x 1" f	0.244	5	25	

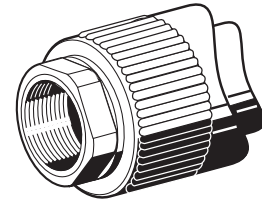

with hex shaped female thread, weld-in surface and weld-in socket for fusion with the inner wall of the pipe.

The necessary tools for the fusion of **fusiotherm®** weld-in saddles are listed on page 171 and 172.

Weld-in saddle tools
Art.-No. 50614-50680

Chamfering tools (only for stabi composite pipe)
Art.-No. 50910+50912+50914

fusiotherm®-drill
Art.-No. 50940, 50941, 50942, 50944, 50946, 50948

fusiotherm®-weld-in saddle with male thread

Art.-No.	Dimension	kg / pc	Packing unit m / pc	Box unit m / pc	Piece
28314	40/25 mm x 1/2" m	0.087	5	300	
28316	50/25 mm x 1/2" m	0.090	5	300	
28318	63/25 mm x 1/2" m	0.088	5	300	
28320	75/25 mm x 1/2" m	0.096	5	300	
28322	90/25 mm x 1/2" m	0.089	5	300	
28324	110/25 mm x 1/2" m	0.089	5	300	
28326	125/25 mm x 1/2" m	0.091	5	300	
28330	160/25 mm x 1/2" m	0.091	5	300	
28334	40/25 mm x 3/4" m	0.107	5	250	
28336	50/25 mm x 3/4" m	0.109	5	250	
28338	63/25 mm x 3/4" m	0.108	5	250	
28340	75/25 mm x 3/4" m	0.108	5	250	
28342	90/25 mm x 3/4" m	0.110	5	250	
28344	110/25 mm x 3/4" m	0.109	5	250	
28346	125/25 mm x 3/4" m	0.111	5	250	
28350	160/25 mm x 3/4" m	0.111	5	250	



Like Art.-No. 28214 - 28250, but with male thread

Distributors and accessories

fuiotherm®-distribution block plumbing

including 1 plug and 2 fastenings

Art.-No.	Dimension	kg / pc	Packing unit m / pc	Box unit m / pc	Piece
30115	20/25 mm	0.276	1	50	

Passage: 25 mm (socket)/ 2 branches: 20 mm (socket)

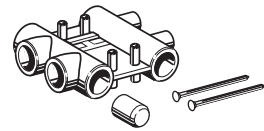

fuiotherm®-distribution block plumbing

with insulation block

Art.-No.	Dimension	kg / pc	Packing unit m / pc	Box unit m / pc	Piece
30130	20/25 mm	0.319	1	30	

Like Art.-No. 30115, but with insulation block - height = 70 mm

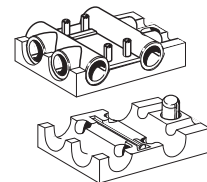

fuiotherm®-four-port manifold

length: 246 mm, with 4 branches

Art.-No.	Dimension	kg / pc	Packing unit m / pc	Box unit m / pc	Piece
30602	32 mm x 16 mm	0.141	1	100	
30604	32 mm x 20 mm	0.134	1	100	

The four-port manifold can be shortened or extended by fusion with further four-port manifolds, if required.

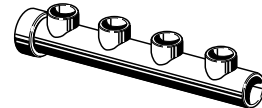

fuiotherm®-manifold end piece with female thread*

Art.-No.	Dimension	kg / pc	Packing unit m / pc	Box unit m / pc	Piece
30804	32 mm x 1/2" f	0.083	1	200	

* **fuiotherm®**- transition piece as manifold endpiece with female thread

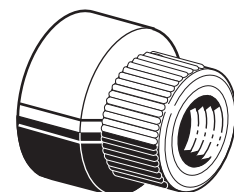

Note:

fuiotherm®-metal compound fittings are manufactured from **fuviolen** PP-R and brass. Metal inserts, without hex shaped spanner flat, with 1/2" and 3/4" F are also available in stainless steel / price on request!

Valves and accessories

fusiotherm®- ball valve for manifold

female / male

Art.-No.	Dimension	kg / pc	Packing unit m / pc	Box unit m / pc	Piece
78000	32 mm	1.168	2	50	

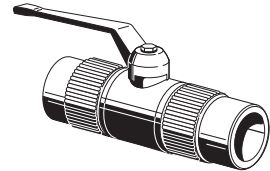

fusiotherm®-supporting strap for four-port manifold

with clamps, galvanized, double

Art.-No.	Dimension	kg / pc	Packing unit m / pc	Box unit m / pc	Piece
60210	for ø 32 mm	0.225	2	100	

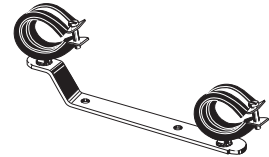

fusiotherm®-globe valve

for surface installation

Art.-No.	Dimension	kg / pc	Packing unit m / pc	Box unit m / pc	Piece
40808	20 mm	0.205	1	100	
40810	25 mm	0.211	1	100	
40812	32 mm	0.351	1	60	
40814	40 mm	0.570	1	35	

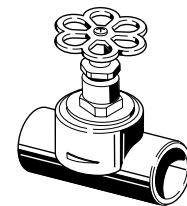

fusiotherm®-concealed valve

chromium plated

Art.-No.	Dimension	kg / pc	Packing unit m / pc	Box unit m / pc	Piece
40858	20 mm	0.323	1	40	
40860	25 mm	0.332	1	40	
40862	32 mm	0.415	1	30	

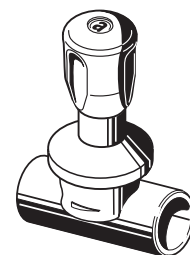

Valves and accessories

fusiotherm®-concealed valve

tamper proof / chromium-plated / short design

Art.-No.	Dimension	kg / pc	Packing unit m / pc	Box unit m / pc	Piece
40868	20 mm	0,294	1	50	
40870	25 mm	0,344	1	40	
40872	32 mm	0,430	1	30	

Art.-No. 40868 + 40870: suitable for construction depth up to 25 mm

Art.-No. 40872: suitable for construction depth up to 30 mm

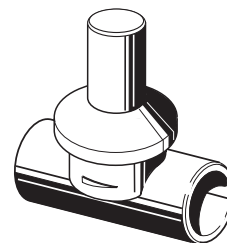

fusiotherm®-concealed valve

chromium-plated

Art.-No.	Dimension	kg / pc	Packing unit m / pc	Box unit m / pc	Piece
40878	20 mm	0.357	1	40	
40880	25 mm	0.370	1	40	
40882	32 mm	0.441	1	20	

suitable for construction depth of 55 mm to 100 mm

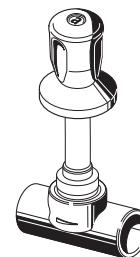

fusiotherm®-concealed valve

tamper proof, chromium-plated

Art.-No.	Dimension	kg / pc	Packing unit m / pc	Box unit m / pc	Piece
40888	20 mm	0.330	1	50	
40890	25 mm	0.341	1	50	
40892	32 mm	0.424	1	40	

suitable for construction depth up to 60 mm

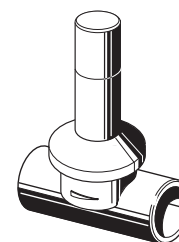

fusiotherm®-extension for fusiotherm® concealed valve

chromium-plated for Art.-No. 40858-40862

Art.-No.	Dimension	kg / pc	Packing unit m / pc	Box unit m / pc	Piece
40900	length = 92 mm	0.137	1	300	
40902	length = 132 mm	0.203	1	200	

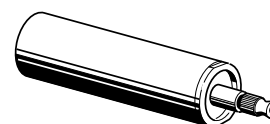

Valves and accessories

fusiotherm®-stop valve body

Art.-No.	Dimension	kg / pc	Packing unit m / pc	Box unit m / pc	Piece
40908	20 mm x 3/4" f	0.106	1	150	
40910	25 mm x 3/4" f	0.098	1	150	
40912	32 mm x 1" f	0.144	1	100	
40914	40 mm x 1 1/4" f	0.309	1	50	

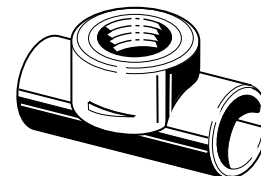

fusiotherm®-inclined valve

without drain

Art.-No.	Dimension	kg / pc	Packing unit m / pc	Box unit m / pc	Piece
41108	20 mm	0.294	1	100	
41110	25 mm	0.282	1	80	
41112	32 mm	0.423	1	50	
41114	40 mm	0.833	1	25	

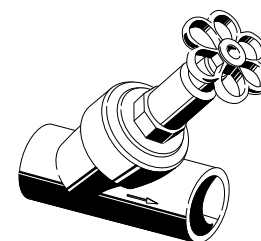

fusiotherm®-non-return valve

without drain

Art.-No.	Dimension	kg / pc	Packing unit m / pc	Box unit m / pc	Piece
41208	20 mm	0.298	1	80	
41210	25 mm	0.286	1	80	
41212	32 mm	0.434	1	50	
41214	40 mm	0.842	1	25	

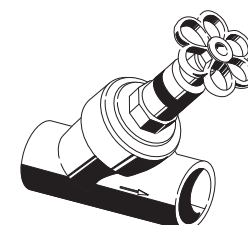

fusiotherm®-ball valve PP / brass

Art.-No.	Dimension	kg / pc	Packing unit m / pc	Box unit m / pc	Piece
41308	20 mm	0.280	1	100	
41310	25 mm	0.371	1	100	
41312	32 mm	0.593	1	60	
41314	40 mm	0.950	1	40	
41316	50 mm	1.585	1	25	
41318	63 mm	2.552	1	15	

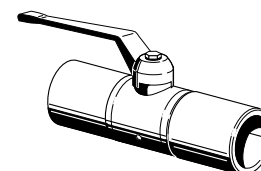

Valves and accessories

fusiotherm®-extension for fusiotherm-ball valve

Art.-No.	Dimension	kg / pc	Packing unit m / pc	Box unit m / pc	Piece
41378	for Art.- No. 41308 / 41310 - length = 35 mm	0.120	1	100	
41382	for Art.- No. 41312 / 41314 - length = 35 mm	0.120	1	100	
41386	for Art.-No. 41316 / 41318 - length = 46 mm	0.273	1	75	

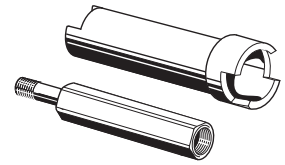

fusiotherm®-PP-ball valve

with union nut and welding socket

Art.-No.	Dimension	DN	kg / pc	Packing unit m / pc	Box unit m / pc	Piece
41388	20 mm	15	0.130	1	200	
41390	25 mm	20	0.200	1	120	
41392	32 mm	25	0.290	1	80	
41394	40 mm	32	0.470	1	55	
41396	50 mm	40	0.740	1	45	
41398	63 mm	50	1.170	1	25	
41400	75 mm	65	2.474	1	4	

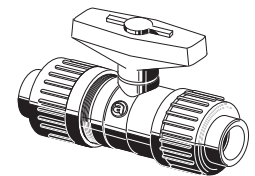

fusiotherm®-PP-ball valve

with flange connection on both sides

Art.-No.	Dimension	DN	kg / pc	Packing unit m / pc	Box unit m / pc	Piece
41402	90 mm	80	9.300	1	3	
41404	110 mm	100	11.300	1	2	
41406	125 mm	100	13.500	1	2	
41407	160 mm	125	27.600	1	1	

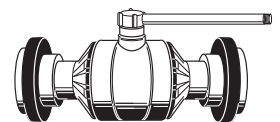

For connection with **fusiotherm®**-weldable flange adapter (Art.-No. 15520-15531) and **fusiotherm®** plastic coated steel flange (Art.-No. 15720-15730)

fusiotherm®-draining branch

to weld in **fusiotherm®** valves

Art.-No.	Dimension	kg / pc	Packing unit m / pc	Box unit m / pc	Piece
41408	20 mm	0.098	1	200	
41410	25 mm	0.094	1	200	
41412	32 mm	0.115	1	150	
41414	40 mm	0.139	1	100	
41416	50 mm	0.201	1	40	
41418	63 mm	0.288	1	25	

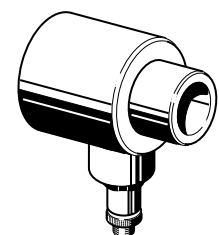

Radiator connections

aquatherm®-connecting bend

Art.-No.	Dimension	kg / pc	Packing unit m / pc	Box unit m / pc	Piece
85119	16 mm	0.083	1	50	

Length: 350 mm
 Including 2 sliding sleeves (Ø 11.7 mm) and 1 fastening plug
 Material: PP-R
 Colour: white
 Connection with two 16 mm welding tools (Art.-No. 50206)
 Suitable distances for fixing at the welding device (Art.-No. 50337) are available

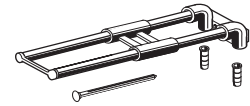

aquatherm®-connecting bend

Art.-No.	Dimension	kg / pc	Packing unit m / pc	Box unit m / pc	Piece
85120	16 mm	0.076	1	100	

Length: 200 mm
 Including 2 sliding sleeves (Ø 11.7 mm) and 1 fastening plug
 Material: PP-R
 Colour: white
 Connection with two 16 mm welding tools (Art.-No. 50206)
 Suitable distances for fixing at the welding device (Art.-No. 50337) are available

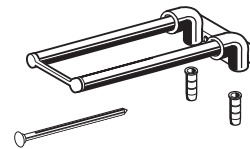

aquatherm®-connecting bend

Art.-No.	Dimension	kg / pc	Packing unit m / pc	Box unit m / pc	Piece
85121	16 mm	0.076	1	100	

Length: 200 mm
 Including 1 fastening plug
 Material: PP-R
 Colour: white
 Connection with two 16 mm welding tools (Art.-No. 50206)
 Suitable distances for fixing at the welding device (Art.-No. 50337) are available

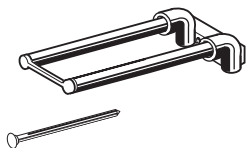

aquatherm®-distribution block

for skirting or floor installation

Art.-No.	Dimension	kg / pc	Packing unit m / pc	Box unit m / pc	Piece
85123	20 / 16 mm	0.091	1	15	

Passage 20 mm, 2 branches, including 1 plug 20 mm
 Material: PP-R
 Colour: green
 Double welding with welding-device (Art.-No. 50337) in connection with two 16 mm and two 20 mm tools is possible.

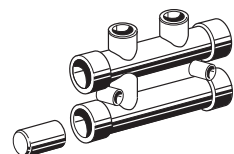

Radiator connections

aquatherm®-red-nipple

Art.-No.	Dimension	kg/ pc	Packing unit m/ pc	Box unit m/ pc	Piece
85115	1/2" m x 3/4" m	0,038	2	120	

for the connection of radiator valves with compact valve radiators with connection 1/2" F



aquatherm®-protection sleeve

Art.-No.	Dimension	kg/ pc	Packing unit m/ pc	Box unit m/ pc	Piece
85125	for Ø 16+17 mm	0.011	10	60	

for protection of connection pipes of vertical radiator connection (from the floor) made of PP-R

Colour: green

Pipe spacing: 50 mm

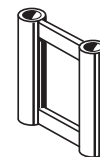

aquatherm®-double-cap rosette

Art.-No.	Dimension	kg/ pc	Packing unit m/ pc	Box unit m/ pc	Piece
79550	for Ø - 17.5 mm	0.009	5	400	

to cover the connection pipes coming out of the floor

Material: PA

Pipe distance: 50 mm

Colour: white



aquatherm®-radiator connection piece

Art.-No.	Dimension	kg/ pc	Packing unit m/ pc	Box unit m/ pc	Piece
83006	16 mm with nut R 3/4"	0.145	1	25	

consisting of:

2 connection pieces (L: 120 mm) made of PP-R, Colour: white

2 metal tension rings

2 nuts, chromium plated

2 adaptors, chromium plated

2 gaskets

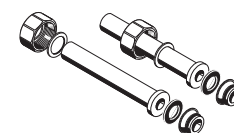

Radiator connections / Cutting tools

aquatherm®-radiator connection piece

with hex shaped threaded connection

Art.-No.	Dimension	kg/ pc	Packing unit m/ pc	Box unit m/ pc	Piece
83306	16 mm x 1/2" m	0.092	10	100	

Material: PP-R
brass thread

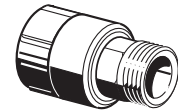

aquatherm®-snap in radius support

Art.-No.	Dimension	kg/ pc	Packing unit m/ pc	Box unit m/ pc	Piece
79566	for pipes 16 & 17 mm	0.024	25	325	
79568	for pipe 20 mm	0.032	20	200	

Material: PE
Colour: black

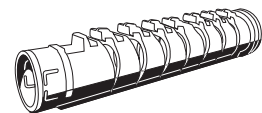

fusiotherm®-pipe cutter

Art.-No.	Dimension	kg/ pc	Packing unit m/ pc	Box unit m/ pc	Piece
50102	for pipes 16 - 40 mm	0.442	1	34	
50105	for pipes 50 - 125 mm	1.496	1		
50106	for pipes 110 - 160 mm	3.834	1		

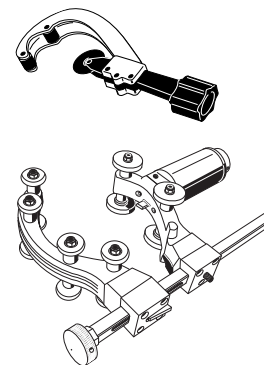

fusiotherm®-pipe cutter

Art.-No.	Dimension	kg/ pc	Packing unit m/ pc	Box unit m/ pc	Piece
50104	for pipes 16 - 40 mm	0.590	1	30	

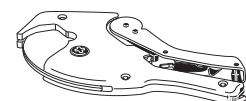

fusiotherm®-orbital circular saw

Art.-No.	Dimension	kg/ pc	Packing unit m/ pc	Box unit m/ pc	Piece
50108	for pipes 160 - 355 mm	15.500	1		

This orbital circular saw can be ordered directly from Rothenberger with Art.-No. 5.5620 (www.rothenberger.com). High-performance orbital circular saw for fast, precise, perfectly aligned and right-angled cutting of plastic pipes 160 - 355 mm at the building site or in the workshop.

Welding devices

fusiotherm®-manual welding device (500 W)

Art.-No.	Dimension	kg/ pc	Packing unit m/ pc	Box unit m/ pc	Piece
50336	for pipes Ø 16 - 32 mm	8.000	1		

with base and case for tools

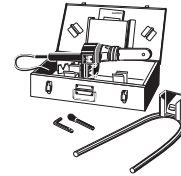

fusiotherm®-manual welding device (800 W)

Art.-No.	Dimension	kg/ pc	Packing unit m/ pc	Box unit m/ pc	Piece
50337	for pipes Ø 16 - 63 mm	8.500	1		

with base and case for tools

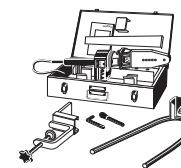

fusiotherm®-manual welding device (1400 W)

Art.-No.	Dimension	kg/ pc	Packing unit m/ pc	Box unit m/ pc	Piece
50341	for pipes Ø 50 - 125 mm	13.730	1		

with base and case for tools

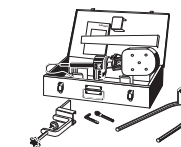

fusiotherm®-welding machine (1400 W)

Art.-No.	Dimension	kg/ pc	Packing unit m/ pc	Box unit m/ pc	Piece
50147	for pipes ø 50 - 125 mm	127.000	1		

including welding tools 50 - 125 mm,

fusiotherm®-manual welding device (1400 W) and wooden transport case

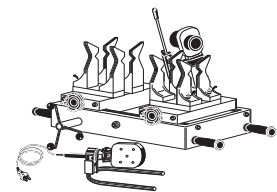

Important:

Do not cut the fusiotherm®-pipes with customary hack saws.

fusiotherm®-pipes can be cut with customary saws equipped with saw blades suitable for plastic.

Welding devices

fusiotherm®-electric welding jig

Art.-No.	Dimension	kg/ pc	Packing unit m/ pc	Box unit m/ pc	Piece
50149	for pipes Ø 63-125 mm	19.000	1		

including standby accumulator, charging station and metal case

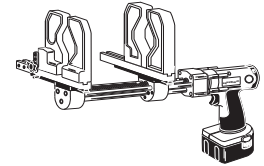

fusiotherm®-base for Art.-No. 50149

Art.-No.	Dimension	kg/ pc	Packing unit m/ pc	Box unit m/ pc	Piece
50151		6.804	1		

fusiotherm®-butt welding machine

Art.-No.	Dimension	kg/ pc	Packing unit m/ pc	Box unit m/ pc	Piece
50163	for pipes ø 160 - 250 mm	252.000	1		

including wooden transport box.

The butt welding machine can be obtained directly from Rothenberger

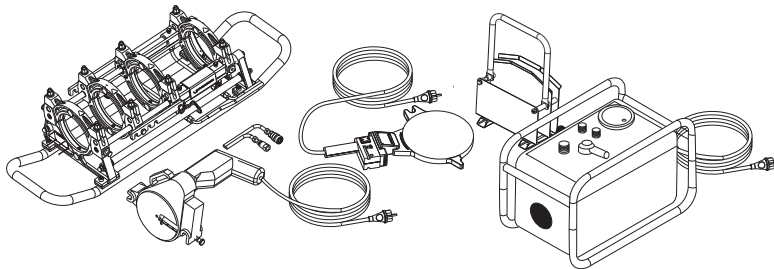

fusiotherm®-clamping elements for butt welding

without milling cutter and heating plate

Art.-No.	Dimension	kg/ pc	Packing unit m/ pc	Box unit m/ pc	Piece
50164	for pipes ø 160 - 250 mm	106.000	1		

including wooden transport box.

The clamping elements can be obtained directly from Rothenberger.

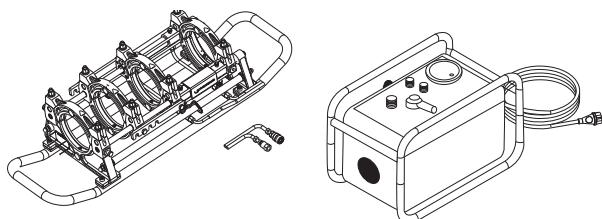

Welding devices and accessories

fusiotherm[®]-electrofusion device

Art.-No.	Dimension	kg/ pc	Packing unit m/ pc	Box unit m/ pc	Piece
50175	for pipes Ø 20-160 mm	20.500	1		

for **fusiotherm**[®]-electrofusion sockets Art.-No. 17208-17230

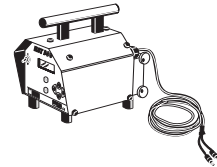

fusiotherm[®]-cleaning wipes

Art.-No.	Dimension	kg/ pc	Packing unit m/ pc	Box unit m/ pc	Piece
50193	Box with 100 towels	0.140	1	20	

for electrofusion sockets



Welding tool and peeling tools

fusiotherm®-welding tool

Art.-No.	Dimension	kg/ pc	Packing unit m/ pc	Box unit m/ pc	Piece
50206	16 mm	0.111	1	100	
50208	20 mm	0.114	1	100	
50210	25 mm	0.143	1	100	
50212	32 mm	0.210	1	80	
50214	40 mm	0.309	1	50	
50216	50 mm	0.459	1	40	
50218	63 mm	0.682	1	25	
50220	75 mm	0.920	1	20	
50222	90 mm	1.422	1	15	
50224	110 mm	2.453	1	10	
50226	125 mm	3.324	1	6	

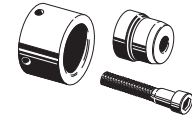

fusiotherm®-repair set

Art.-No.	Dimension	kg/ pc	Packing unit m/ pc	Box unit m/ pc	Piece
50307	7 mm	0.143	1	50	
50311	11 mm	0.177	1	50	

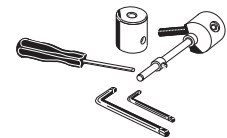

to close holes of up to 10 mm in the pipe (pipe repair stick Art.-No. 60600)

fusiotherm®-pipe repair stick

for pipe reparation

Art.-No.	Dimension	kg/ pc	Packing unit m/ pc	Box unit m/ pc	Piece
60600	7/11 mm	0.008	10	2500	

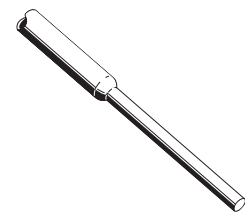

fusiotherm®-peeling tool

for stabi-composite pipe

Art.-No.	Dimension	kg/ pc	Packing unit m/ pc	Box unit m/ pc	Piece
50506	16 & 20 mm	0.429	1	30	
50508	20 & 25 mm	0.397	1	25	
50512	32 & 40 mm	0.670	1	13	
50514	40 & 50 mm	1.007	1	8	
50518	63 & 75 mm	1.520	1	6	
50524	90 & 110 mm	3.098	1	2	

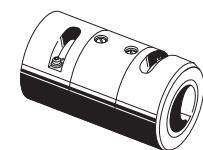

Peeling tools

fusiotherm®-peeling tool

for electrofusion sockets Art.-No.17208-17230

Art.-No.	Dimension	kg / pc	Packing unit m / pc	Box unit m / pc	Piece
50558	20 mm	0.226	1	30	
50560	25 mm	0.274	1	20	
50562	32 mm	0.339	1	15	
50564	40 mm	0.490	1	14	
50566	50 mm	0.639	1	8	
50568	63 mm	0.837	1	4	
50570	75 mm	1.048	1	3	
50572	90 mm	1.392	1	2	
50574	110 mm	1.247	1	6	
50576	125 mm	1.479	1	1	
50580	160 mm	1.841	1	5	

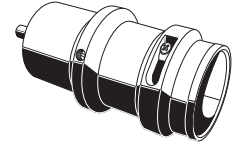

Special peeling tools have to be used for **fusiotherm®**-stabi composite pipes and for sliding electrofusion sockets.

Please contact our sales department!

fusiotherm®-spare blade

for peeling tools Art.-No. 50506-50524, 50558-50570

Art.-No.	Dimension	kg / pc	Packing unit m / pc	Box unit m / pc	Piece
50440		0.005	1		

Welding tools and accessories

fusiotherm®-welding tool

For welding of saddles of Art.-No. 15156-15253 and 28214-28274

Art.-No.	Dimension	kg/ pc	Packing unit m/ pc	Box unit m/ pc	Piece
50614	40 x 20/25 mm	0.187	1	40	
50616	50 x 20/25 mm	0.220	1	35	
50619	63 x 20/25 mm	0.242	1	35	
50620	63 x 32 mm	0.243	1	35	
50623	75 x 20/25 mm	0.256	1	30	
50624	75 x 32 mm	0.258	1	30	
50625	75 x 40 mm	0.449	1	20	
50627	90 x 20/25 mm	0.268	1	30	
50628	90 x 32 mm	0.277	1	30	
50629	90 x 40 mm	0.464	1	20	
50631	110 x 20/25 mm	0.279	1	30	
50632	110 x 32 mm	0.288	1	30	
50634	110 x 40 mm	0.483	1	20	
50635	110 x 50 mm	0.777	1	12	
50636	125 x 20/25 mm	0.292	1	30	
50638	125 x 32 mm	0.301	1	30	
50640	125 x 40 mm	0.511	1	20	
50642	125 x 50 mm	0.790	1	12	
50644	125 x 63 mm	1.227	1	6	
50648	160 x 20/25 mm	0.323	1	20	
50650	160 x 32 mm	0.336	1	20	
50652	160 x 40 mm	0.544	1	15	
50654	160 x 50 mm	0.839	1	10	
50656	160 x 63 mm	1.287	1	8	
50660	200 x 20/25 mm	0.201	1	35	
50662	200 x 32 mm	0.231	1	35	
50664	200 x 40 mm	0.402	1	20	
50666	200 x 50 mm	0.645	1	12	
50668	200 x 63 mm	1.044	1	8	
50672	250 x 20/25 mm	0.202	1	35	
50674	250 x 32 mm	0.232	1	35	
50676	250 x 40 mm	0.402	1	20	
50678	250 x 50 mm	0.661	1	12	
50680	250 x 63 mm	1.067	1	8	

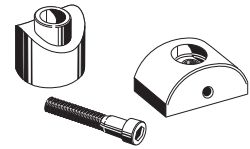

fusiotherm®-chamfering device

Art.-No.	Dimension	kg/ pc	Packing unit m/ pc	Box unit m/ pc	Piece
50910	20 & 25 mm	0.213	1	20	
50912	32 mm	0.319	1	15	
50914	40 mm	0.470	1	12	

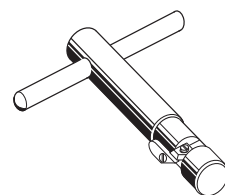

for removal of the aluminium swarfs at the drill hole only with stabi-composite pipes - to prepare the saddle welding

Only for stabi-composite pipes!

Accessories

fusiotherm®-drill

for installation of weld-in saddles

Art.-No.	Dimension	kg / pc	Packing unit m / pc	Box unit m / pc	Piece
50940	20 & 25 mm (for pipes 40 - 160 mm)	0.140	1	50	
50941	20 & 25 mm (for pipes 63 - 250 mm)	0.160	1	50	
50942	32 mm	0.207	1	45	
50944	40 mm	0.286	1	40	
50946	50 mm	0.319	1	25	
50948	63 mm	0.454	1	15	

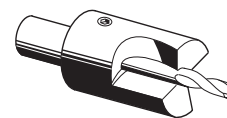

* may only be used in fixed drilling machines!

**Our general conditions of sale and delivery (date: 02/2007):
These are printed completely on our homepage www.aquatherm.de
or we will send them to you on demand!**

Subject to technical changes.

Legend

Chapter 1

Specification

Chapter 4

Installation

Principles

Chapter 5

Planning

Chapter 6

Product Range

Designation	Symbol	Unit
Induced stress ($\sigma = \text{sigma}$)	σ_v	N/mm ²
Pressure	p	mbar (bar)
Safety-factor	Sf	-
Linear expansion ($\Delta = \text{delta}$)	ΔL	mm
Pipe length	L	m
Expansion coefficient ($\alpha = \text{alpha}$)	α	mm/mK
Working temperature	T _w	°C
Installation temperature	T _M	°C
Difference in temperatur ($D = \text{delta}$)	ΔT	K
Length of the bending side	L _s	mm
Bending side with pre-press	L _{sv}	mm
Material specific constant	K	mm
Width of the expansion loop	A _{min}	mm
Safe distance	SA	mm
Area	A	mm ²
Circulatory	\dot{V}	l/s
Pressure gradient	R	mbar/m
Minimum pressure of flow	P _{min Fl}	mbar (bar)
Flow rate	v	m/s
Cold Water Volume Rate	K _v	m ³ /h
Coefficient of loss ($\zeta = \text{Zeta}$)	ζ	-
Diameter	d	mm
Internal diameter	d _a	mm
External diameter	d _i	mm
Wall thickness	s	mm
Insulation thickness	s _i	mm

